

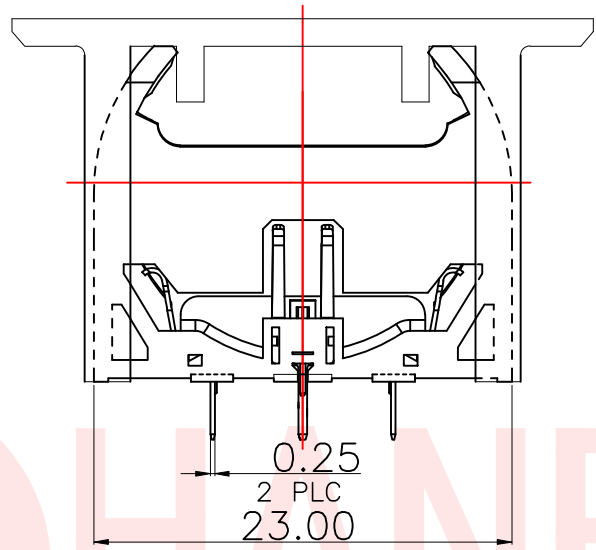

REV.	ECN NO OR DESCRIPTION	REVISED	DATE

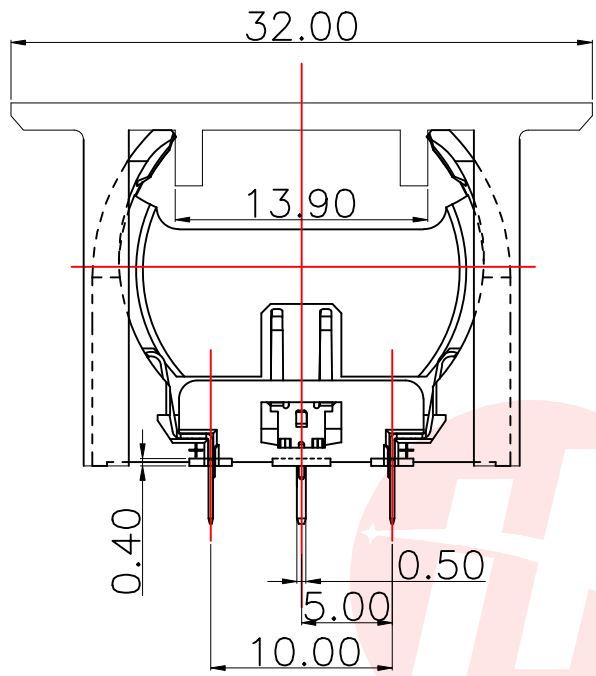

NOTES:

MATERIAL:

1. HOUSING: PA66,30%G.F UL94V-0,COLOR: BLACK OR BLUE.
2. CONTACT: SUS304.
3. CONTACT PLATED: GOLD FLASH PLATED ON CONTACT AREA, TIN PLATED ON SOLDER TAILS, NICKEL UNDER PLATED OVER ALL.

ELECTRICAL CHARACTERISTICS:

1. CURRENT RATING: 1.5AMP.
2. CONTACT RESISTANCE: 30mΩ MAX.
3. INSULATION RESISTANCE: 1000MΩ MIN AT 500V DC.
4. DIELECTRIC WITHSTANDING VOLTAGE: 750V AC RMS FOR 1 MINUTE.
5. OPERATING TEMPERATURE : -55°C TO +105°C.

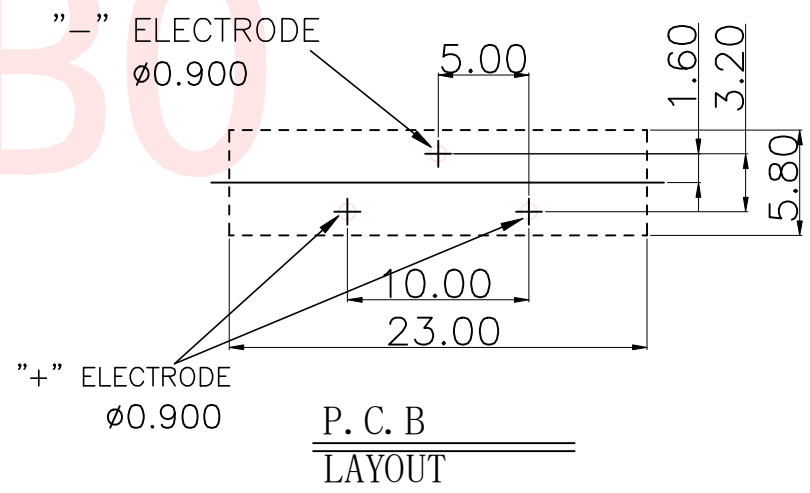
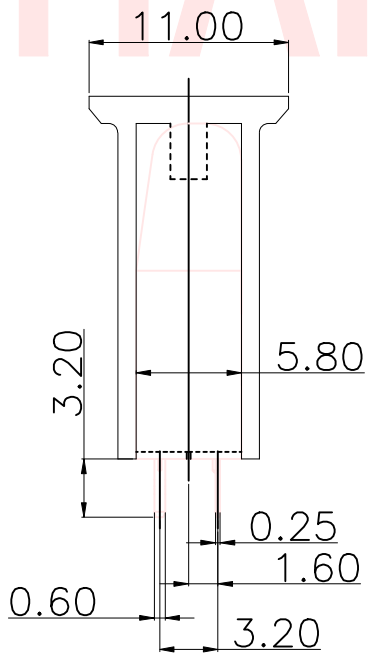
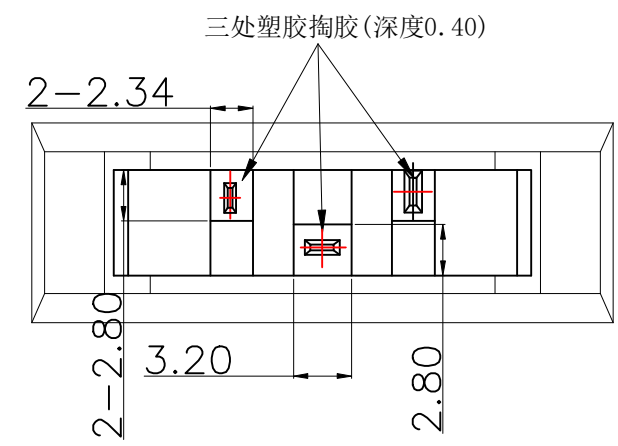

UNLESS OTHERWISE SPECIFIED TOLERANCES

DECIMALS:	ANGLES:
X :±0.30	X :±2°
X.X :±0.20	X.X :±1°
X.XX :±0.10	

东莞市汉博电子科技有限公司
DONGGUAN HANBO TECHNOLOGY CO., LTD

TITLE	BS Cell connector		
DWN	xiong	PART NO. BS-170903Z	
CHKD	lee	SCALE:1:1	UNIT: mm
APVD	wang	SIZE: A4	SHEET:10F 1
			REV: A4

CUSTOMER COPY