

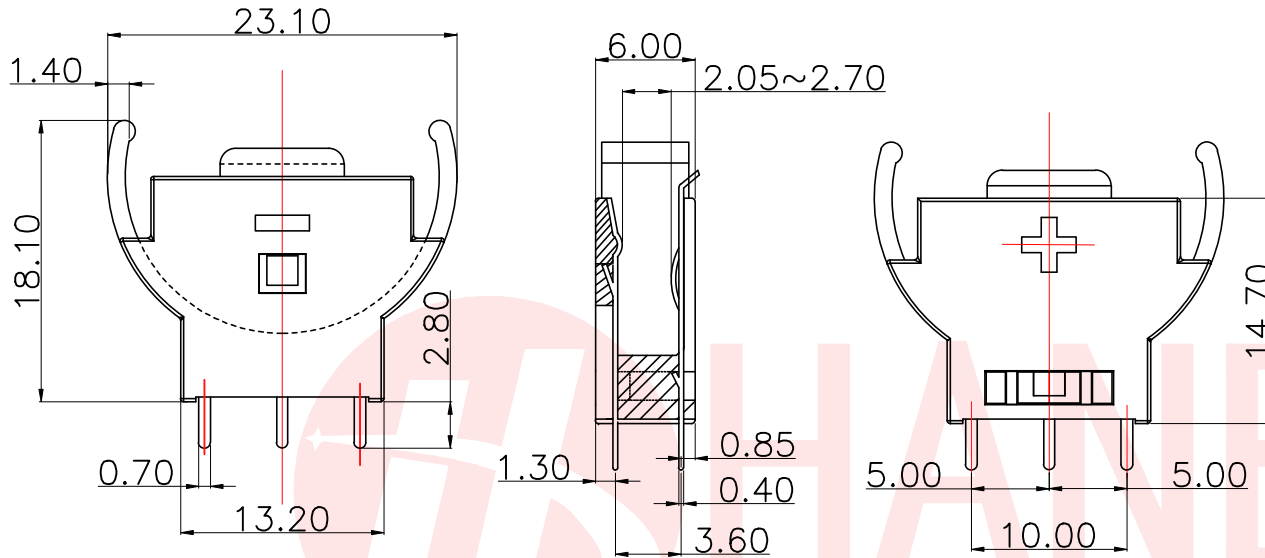

REV.	ECN NO OR DESCRIPTION	REVISED	DATE



NOTES:

MATERIAL:

1. HOUSING: PA66,30%G.F UL94V-0,COLOR: BLACK.
2. CONTACT: BRASS.
3. CONTACT PLATED: TIN PLATED ON OVER ALL, AND NICKEL UNDER PLATED OVER ALL.

ELECTRICAL CHARACTERISTICS:

1. CURRENT RATING: 1.5AMP.
2. CONTACT RESISTANCE $\leq 30m$ MAX.
3. INSULATION RESISTANCE: $\geq 1000M$ MIN AT 500V DC.
4. DIELECTRIC WITHSTANDING VOLTAGE: 750V AC RMS FOR 1 MINUTE.
5. OPERATING TEMPERATURE : $-55^{\circ}C$ TO $+105^{\circ}C$.

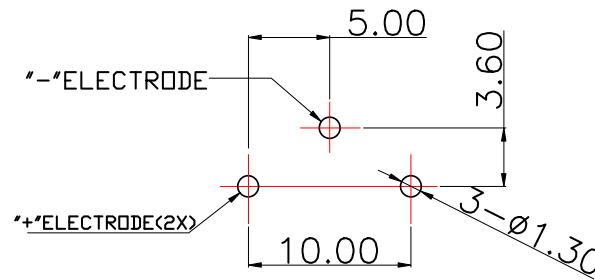
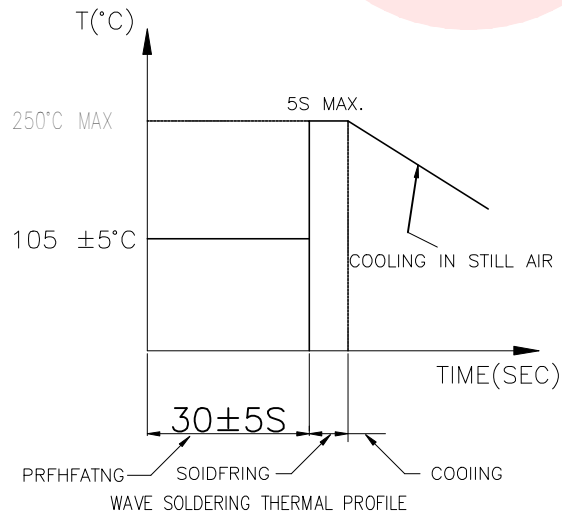

P. C. B LAYOUT

UNLESS OTHERWISE SPECIFIED TOLERANCES

DECIMALS:	ANGLES:
X : ±0.30	X : ±2°
X.X : ±0.20	X.X : ±1°
X.XX : ±0.10	

东莞市汉博电子科技有限公司
DONGGUAN HANBO TECHNOLOGY CO., LTD

TITLE	BS Cell connector			
DWN	xiong	PART NO. BS-170603		
CHKD	lee	SCALE:1:1	UNIT: mm	
APVD	wang	SIZE: A4	SHEET:10F 1	REV: A4

CUSTOMER COPY