



REV.	ECN NO OR DESCRIPTION	REVISED	DATE

NOTES:

MATERIAL:

1. HOUSING: LCP/PBT,30%G.F UL94V-0,COLOR: BLACK,ROHS2.0+HF.
2. CONTACT: Barss.
3. CONTACT PLATED: FULL GOLD PLATED ON OVER ALL, AND NICKEL UNDER PLATED OVER ALL.

ELECTRICAL CHARACTERISTICS:

1. CONTACT RESISTANCE: 30mΩ MAX.
2. INSULATION RESISTANCE: 1000MΩ MIN
3. DIELECTRIC WITHSTANDING VOLTAGE: 1000V AC RMS FOR 1 MINUTE.
4. OPERATING TEMPERATURE : -55°C TO +105°C.

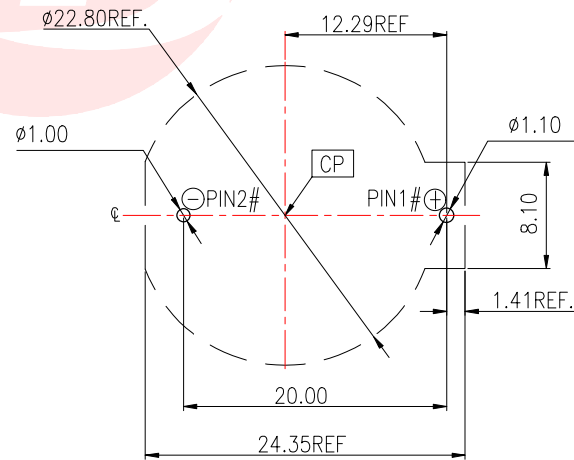
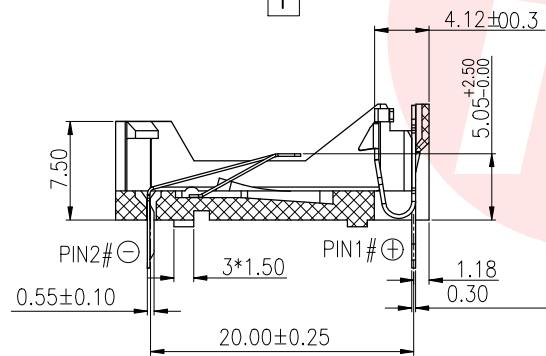
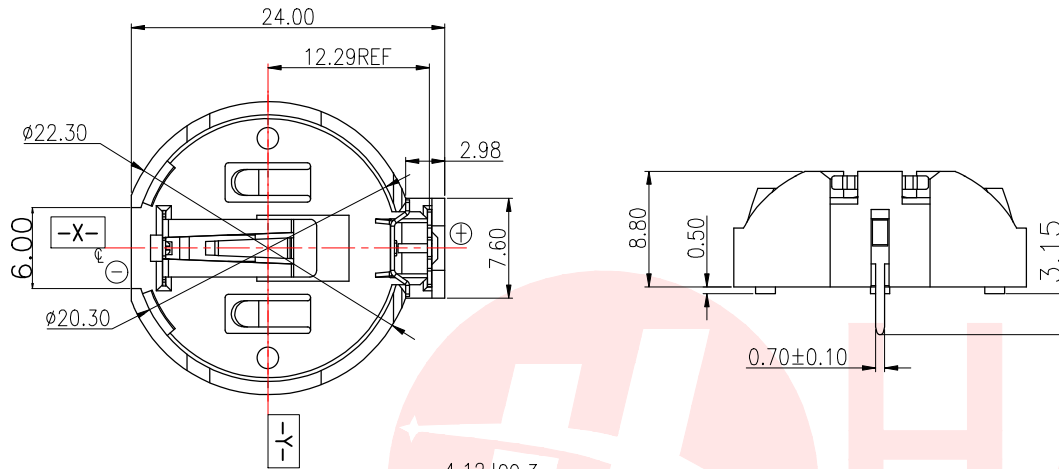

RECOMMENDED PCB LAYOUT(TOP VIEW)  
(PCB THICKNESS:T=1.60mm)(TOLERANCE:±0.05)

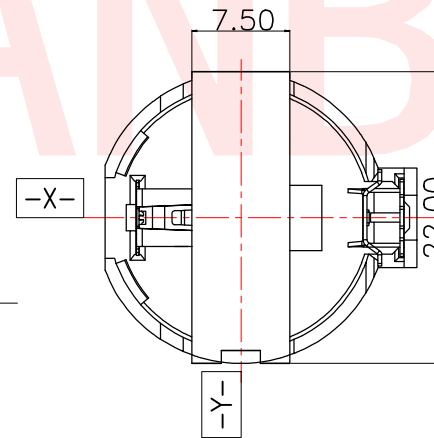

PIP

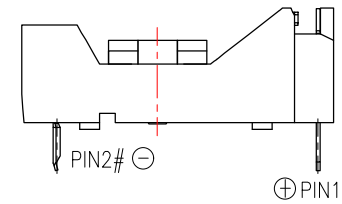
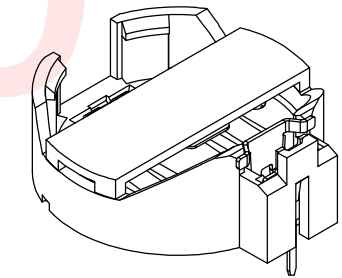

UNLESS OTHERWISE SPECIFIED TOLERANCES

DECIMALS:	ANGLES:
X :±0.30	X :±2°
X.X :±0.20	X.X :±1°
X.XX :±0.10	



东莞市汉博电子科技有限公司  
DONGGUAN HANBO TECHNOLOGY CO., LTD

TITLE		BS DIP		
DWN	xiong	PART NO. BS-170002		
CHKD	lee	SCALE:1:1	UNIT: mm	
APVD	wang	SIZE: A4	SHEET:10F 1	REV: A4
CUSTOMER COPY				