

Series: .050" (1,27 mm) Tiger Eye™ Double / Single Row Discrete Wire Cable Assembly, Socket / Terminal

SFSD(T)/SFSS(T) Series Cable Assemblies

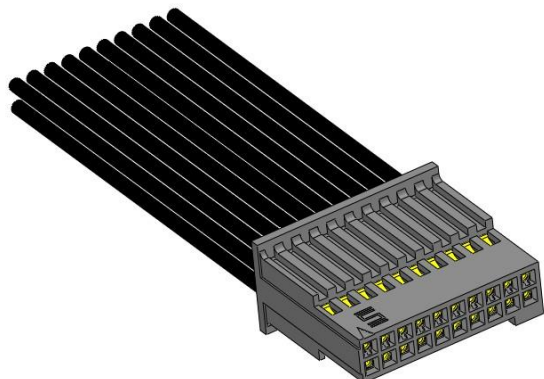

TFSD(T)/TFSS(T) Series Cable Assemblies

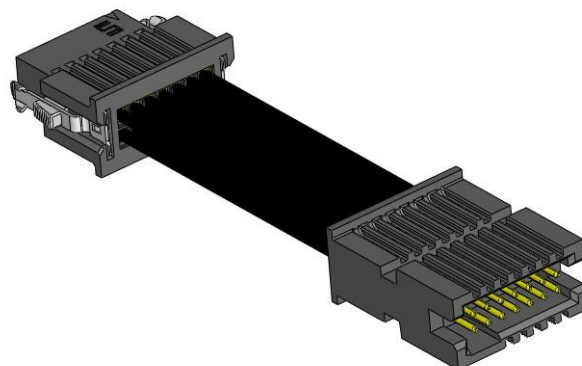

CC03 Crimp Contact

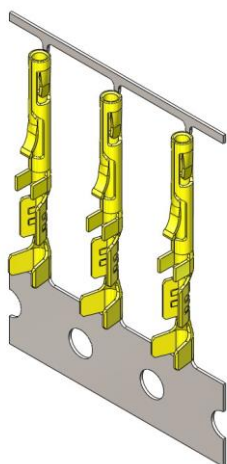

T1M44 Crimp Terminal

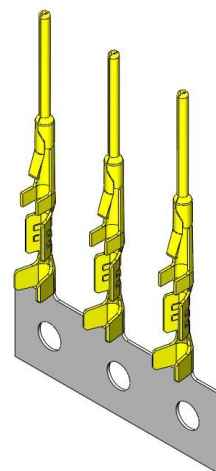

ISDF Series Socket Housings

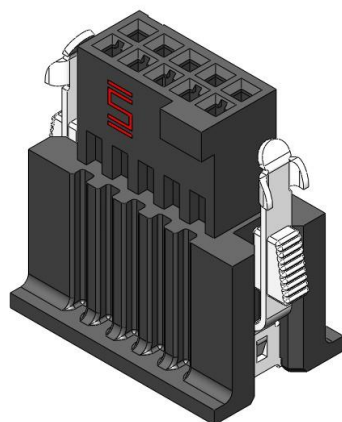

TSDF Series Terminal Housings

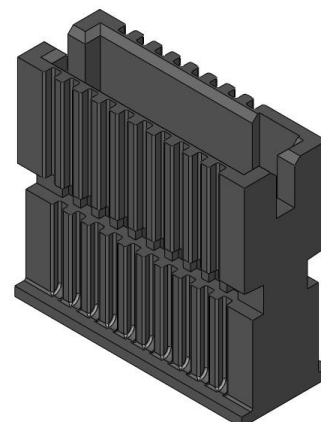

Series: .050" (1,27 mm) Tiger Eye™ Double / Single Row Discrete Wire Cable Assembly, Socket / Terminal

1.0 SCOPE

1.1 This specification covers performance, testing and quality requirements for Samtec .050" (1,27mm) Tiger Eye™ Double / Single Row Discrete Wire Cable Assembly Socket / Terminal System. Testing was performed using a dual row, female SFSD Series cable assembly mated to a TFM Series terminal strip unless otherwise noted.

2.0 DETAILED INFORMATION

2.1 Product prints, footprints, catalog pages, test reports and other specific, detailed information can be found at www.samtec.com/cable-systems/discrete-wire/050-inch/tiger-eye.aspx#comp.

3.0 PRODUCT DESCRIPTION

3.1 Product Series

ITEM	SOCKET	TERMINAL
Crimp Contacts	CC03R, CC03M	T1M44-R, T1M44-M
Housings	ISDF	TSDF
Mating connectors	TFM, TFC, TFSD(T), TFSS(T)	SFM, SFC, SFSD(T), SFSS(T)
Cable Assemblies	SFSD (T), SFSS(T)	TFSD(T), TFSS(T)

3.2 Materials and Platings

ITEM	SOCKET	TERMINAL
Contact Material	BeCu	BeCu
Contact Plating	Au over 50u" Ni	Au over 50u" Ni
Housing Material	Black LCP	Black LCP
Insulation Material (Cable Assemblies only)	PVC, or Teflon	PVC, or Teflon

3.3 Agency Approvals

ITEM	SOCKET	TERMINAL
UL File Numbers	E111594	E111594
Flammability Rating	94V-0	94V-0
RoHS	RoHS Compliant	RoHS Compliant
REACH	REACH 114 Compliant	REACH 114 Compliant

Series: .050" (1,27 mm) Tiger Eye™ Double / Single Row Discrete Wire Cable Assembly, Socket / Terminal

4.0 TESTING

4.1 Current Rating: 2.9 A (One Pin Powered Per Row)

4.2 Voltage Rating: 275 VAC

4.3 Operating Temperature Range:

Components: -55°C to +125°C

Cable Assembly with PVC Cable: -10°C to +80°C

Cable Assembly with Teflon Cable: -40°C to +125°C

4.4 Operating Humidity Range: 90% to 95% (Per EIA-364-31)

4.5 Electrical

ITEM	TEST CONDITION	REQUIREMENT	STATUS
Withstanding Voltage	EIA-364-20 (No Flashover, Spark-over, or Breakdown)	825 VAC	Pass
Insulation Resistance	EIA-364-21 (1000 MΩ minimum)	5, 000 MΩ	Pass
Contact Resistance (LLCR)	EIA-364-23	Δ15 mΩ maximum (Samtec defined)/ No damage	Pass

4.6 Mechanical

ITEM	TEST CONDITION	REQUIREMENT	STATUS
Durability	EIA-364-09C	100 cycles (10u" Au)	Pass
Random Vibration	EIA-364-28 Condition V, Letter B 7.56 G 'RMS', 50 to 2000 Hz, 2 hours per axis, 3 axis total , PSD 0.04	Visual Inspection: No Damage LLCR: Δ 15 mΩ maximum Event Detection: No interruption > 50 Nanoseconds	Pass
Mechanical Shock	EIA-364-27 100 G, 6 milliseconds, sawtooth wave, 11.3 fps, 3 shocks/direction, 3 axis (18 total shocks)	Visual Inspection: No Damage LLCR: Δ 15 mΩ maximum Event Detection: No interruption > 50 Nanoseconds	Pass
Normal Force	EIA-364-04	30 grams minimum for gold interface	Pass

Series: .050" (1,27 mm) Tiger Eye™ Double / Single Row Discrete Wire Cable Assembly, Socket / Terminal

4.7 Environmental

ITEM	TEST CONDITION	REQUIREMENT	STATUS
Thermal Shock	EIA-364-32 Thermal Cycles: 100 (30 minute dwell) Hot Temp: 85°C Cold Temp: -55°C Hot/Cold Transition: Immediate	Visual Inspection: No Damage LLCR: Δ 15 m Ω DWV: 825 VAC IR: >15,000 M Ω	Pass
Thermal Aging (Temp Life)	EIA-364-17 Test Condition 4 @ 105°C Condition B for 250 hours	Visual Inspection: No Damage LLCR: Δ 15 m Ω DWV: 825 VAC IR: >15,000 M Ω	Pass
Cyclic Humidity	EIA-364-31 Test Temp: 25°C to 65°C Relative Humidity: 90 to 95% Test Duration: 240 hours	Visual Inspection: No Damage LLCR: Δ 15 m Ω DWV: 825 VAC IR: >15,000 M Ω	Pass
Gas Tight	EIA-364-36 Gas Exposure: Nitric Acid Vapor Duration: 60 min. Drying Temp.: 50°C +/- 3°C Measurements: Within 1 hour of Exposure	LLCR: Δ 15 m Ω	Pass

5.0 MATED SYSTEM

5.1 Polarizing Features - Asymmetrical polarization notch prevents mis-mating connectors.

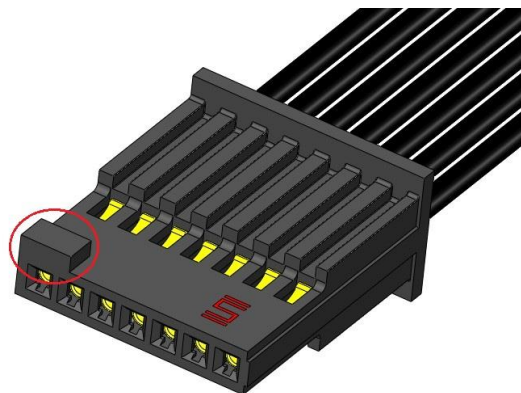

Series: .050" (1,27 mm) Tiger Eye™ Double / Single Row Discrete Wire Cable Assembly, Socket / Terminal

5.2 Latching Features – Optional squeeze latches assure positive engagement for cable assemblies.

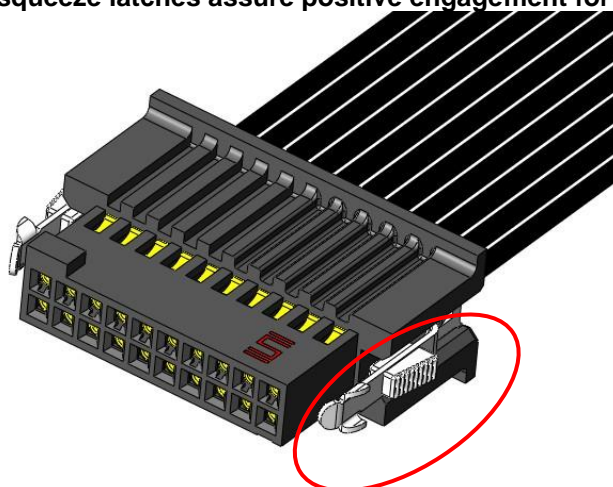

5.3 Mated Views

Mated view information can be found at link below:

<http://www.samtec.com/documents/webfiles/cpdf/SFSX%20Mated%20Document.pdf>

<http://www.samtec.com/documents/webfiles/cpdf/TFSX-SFXX%20MATED%20DOCUMENT-MKT.pdf>

5.4 Mating Angle Requirements: Cable must be axially aligned to connector when mated and un-mated.

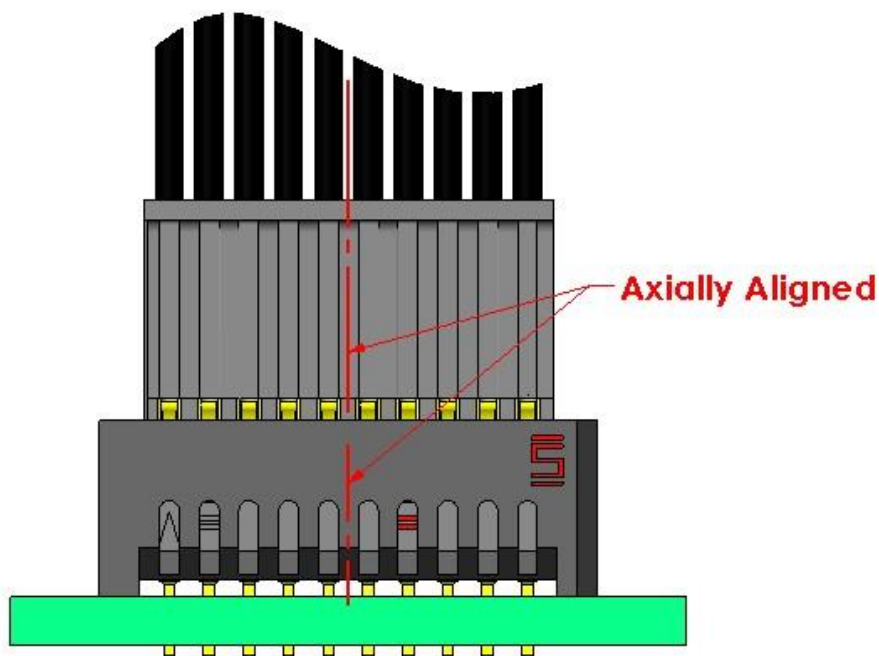

Series: .050" (1,27 mm) Tiger Eye™ Double / Single Row Discrete Wire Cable Assembly, Socket / Terminal

5.5 Screw Down Mating Requirements: Screws must be tightened in .060" increments, alternating side to side; Tighten fasteners to 8 in OZ Max.

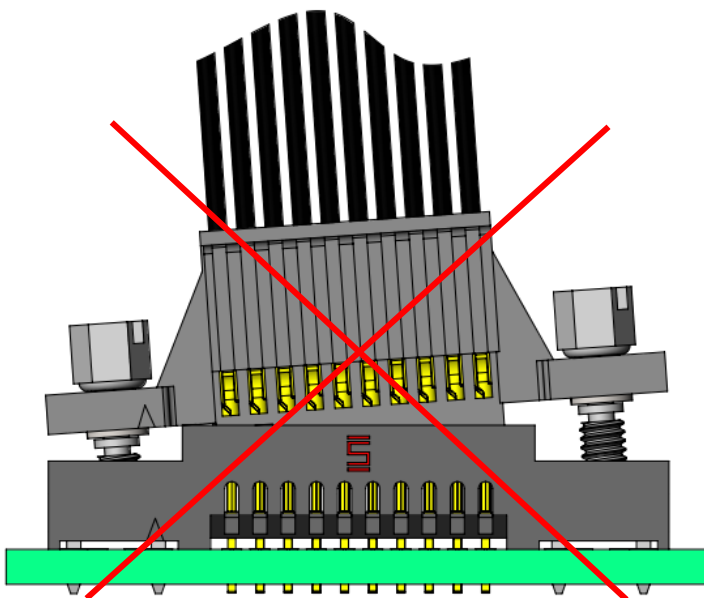
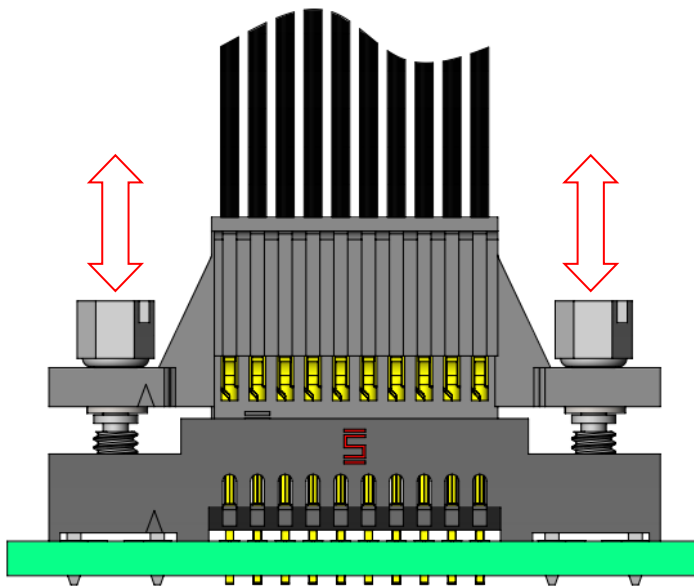

Series: .050" (1,27 mm) Tiger Eye™ Double / Single Row Discrete Wire Cable Assembly, Socket / Terminal

6.0 CRIMP RECOMMENDATIONS AND CABLE PREPARATION

Crimp recommendation and cable preparation can be found on the links below:

<http://www.samtec.com/documents/webfiles/cpdf/CC03X-XXXX-01-XX-MKT.pdf>

<http://www.samtec.com/documents/webfiles/cpdf/T1M44-X-XXXX-01-XX-MKT.pdf>

7.0 APPLICATION INFORMATION

7.1 Cable Management: Samtec recommends some form of cable management to prevent non-axial forces being applied to the connector.

7.2 Application Tools

Application tooling information can be found at link below:

<https://www.samtec.com/tooling.aspx#filter=050>

8.0 ADDITIONAL RESOURCES

8.1 For general application and product assistance, contact our Rugged Product Group at RUGGED@samtec.com.

8.2 For RoHS, REACH or other environmental compliance information, contact our Product Environmental Compliance Group at PEC@samtec.com

8.3 For additional mechanical testing or product information, contact our Customer Engineering Support at CES@samtec.com

8.4 For any questions regarding tooling or assembly processes, contact our Tooling Group at ATG@samtec.com

USE OF PRODUCT SPECIFICATION SHEET

This Product Specification Sheet ("PSS") is a brief summary of information related to the Product identified. As a summary, it should only be used for the limited purpose of considering the purchase/use of Product. For specific, detailed information, including but not limited to testing and Product footprint, refer to Section 2.0 of this document and the links there provided to test reports and prints. This PSS is the property of Samtec, Inc. ("Samtec") and contains proprietary information of Samtec, our various licensors, or both. Samtec does not grant express or implied rights or license under any patent, copyright, trademark or other proprietary rights and the use of the PSS for building, reverse engineering or replication is strictly prohibited. By using the PSS, the user agrees to not infringe, directly or indirectly, upon any intellectual property rights of Samtec and acknowledges that Samtec, our various licensors, or both own all intellectual property therein. The PSS is presented "AS IS". While Samtec makes every effort to present excellent information, the PSS is only provided as a guideline and does not, therefore, warrant it is without error or defect or that the PSS contains all necessary and/or relevant information about the Product. The user agrees that all access and use of the PSS is at its own risk. **NO WARRANTIES EXPRESSED OR IMPLIED, INCLUDING ANY WARRANTY OF MERCHANTABILITY, FITNESS FOR A PARTICULAR PURPOSE OR OF ANY KIND WHATSOEVER ARE PROVIDED.**