

Verpackt im Gurt in Anlehnung an DIN IEC 60286-3
 tape on reel packaging according to DIN IEC 60286-3
 Verpackungseinheit: 160 Stück
 packaging unit: 160 pcs

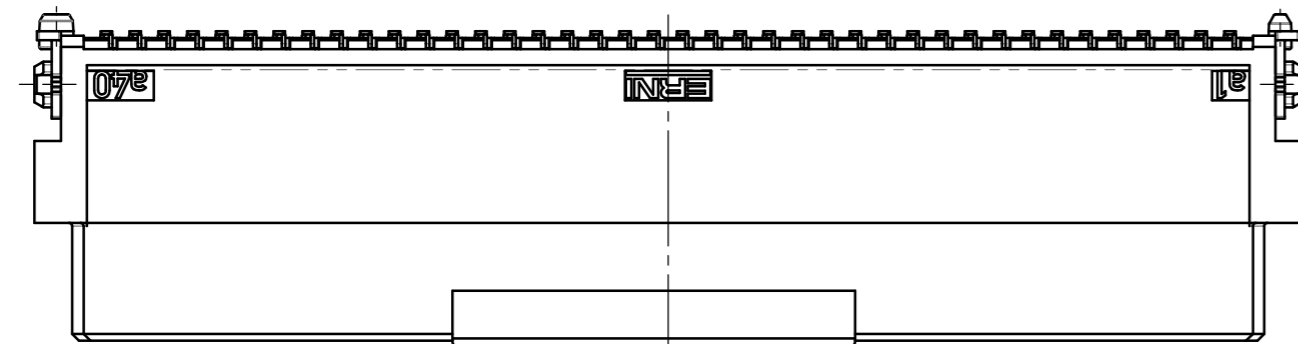

Abspulrichtung - reel off direction

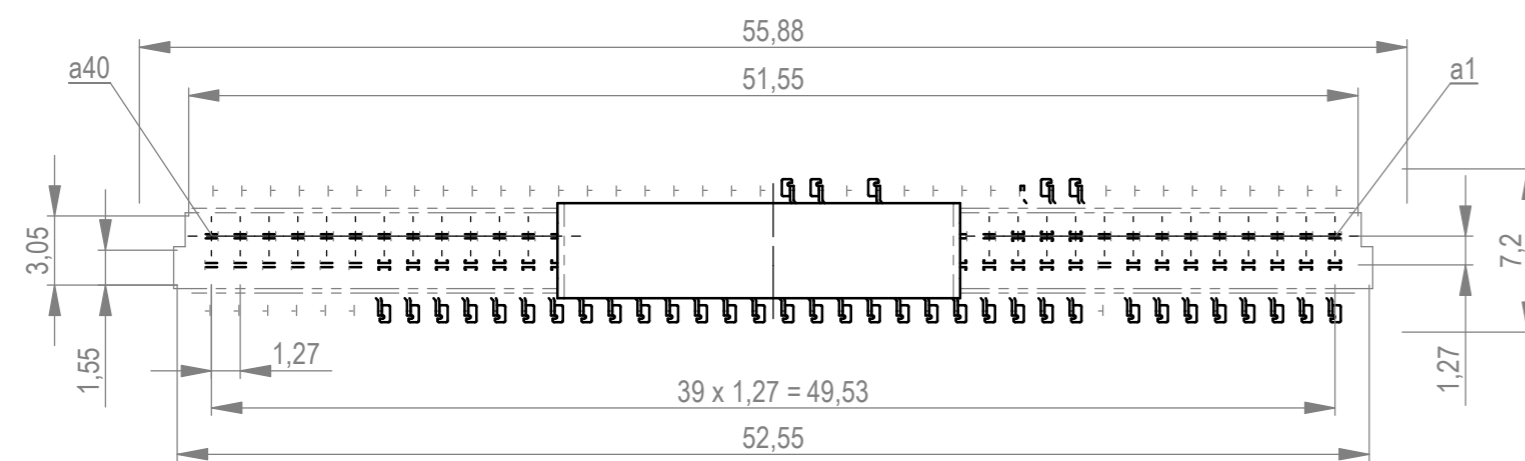
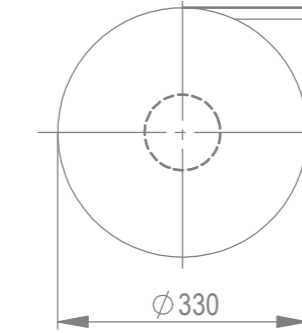
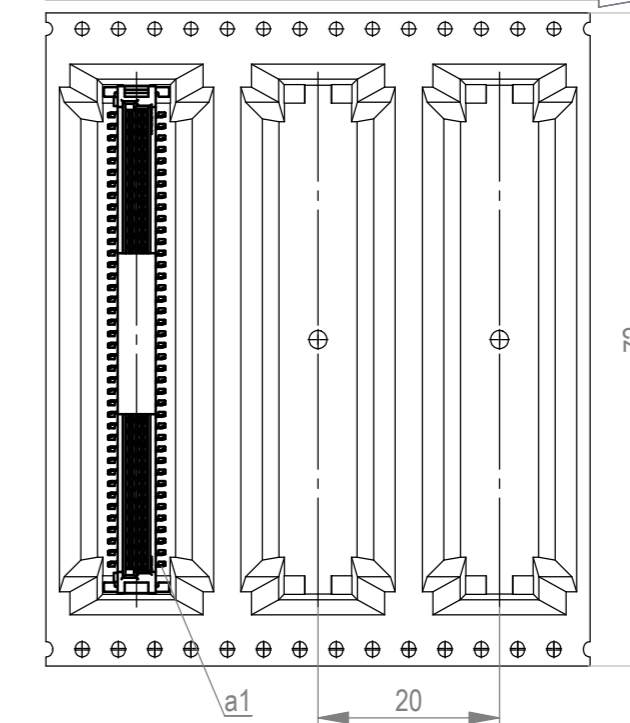

Leiterplatten-Layout Vorschlag für SMT
 PCB-Layout Proposal for SMT

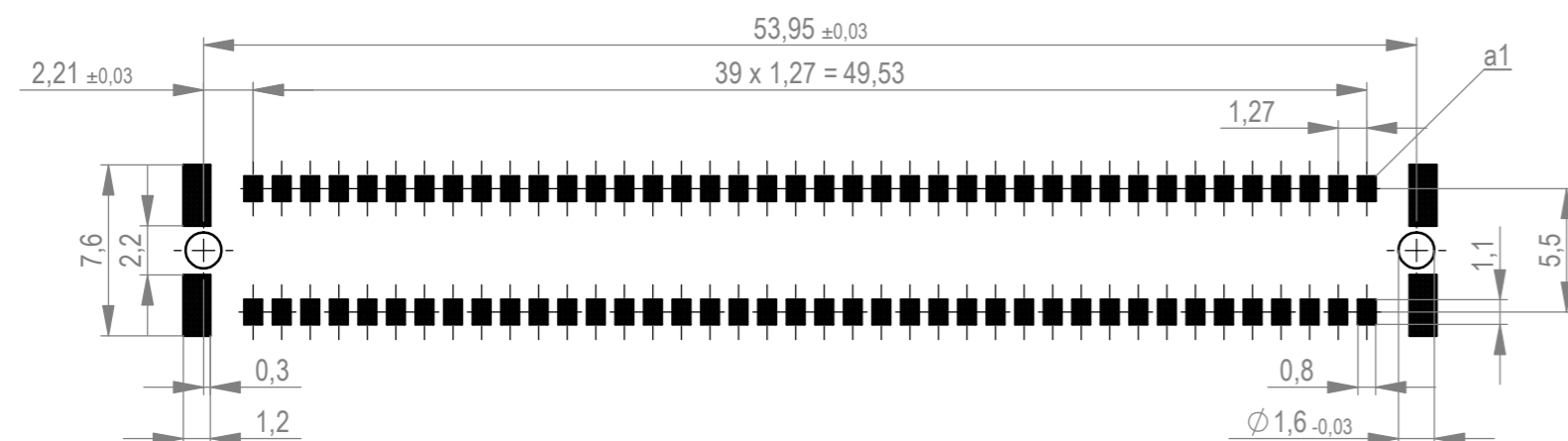

Anforderungsstufe 1
 performance level 1

Kontaktbereich vergoldet
 mating area gold plating

Anschlussbereich verzinkt 4-6 µm
 terminal area 4-6 µm tin plating

Koplanarität der Anschlüsse ≤ 0,1 mm
 coplanarity area of termination ≤ 0,1 mm

BA 7-23 - hohe Bauhöhe
 type 7-23 - high profile

Dimension no.	Tolerances ISO 8015	Scale 5:1 Material	
Customer drawing: This Drawing is a controlled Document.	Subject to modification without prior notice. Drawing will not be updated.	Federl. SMC-B 80-SMD-BA7-23 Female SMC-B 80-SMT-type7-23	
TE Connectivity		C-234201-E	C A2
d1 Index	12.05.2023 Date	Class SMCB	

Wskazówki i uwagi dotyczące tego dokumentu, uwzględnienie zmian i poprawek należy zgłaszać do wytwórcy. Nie należy dokonywać zmian w tym dokumencie bez zgody wytwórcy. All rights reserved for the event of the grant of a patent, utility model or design.