

Overview

The PHE845 series is constructed of metallized polypropylene film encapsulated with self-extinguishing resin in a box of material that meets the requirements of UL 94 V-0.

Applications

For use as an electromagnetic interference (EMI) suppression filter in across-the-line applications that require X1 safety classification. Suitable for use in situations in which capacitor failure does not pose a danger of electric shock.

Benefits

- Approvals: ENEC, UL, cUL
- Class X1 (IEC 60384-14)
- THB Grade IA: 40°C, 93% RH, 500 hours at 760 V URAC acc. to IEC 60384-14
- Rated voltage: 760 VAC 50/60 Hz
- Capacitance range: 0.01 – 1.0 μ F
- Lead spacing: 22.5 – 37.5 mm
- Capacitance tolerance: \pm 20%, \pm 10%
- Climatic category 40/105/56/B, IEC 60068-1
- Tape & Reel in accordance with IEC 60286-2
- RoHS compliant and lead-free terminations
- Operating temperature range of -40°C to +105°C
- 100% screening factory test at 4,250 VDC
- Self-healing properties

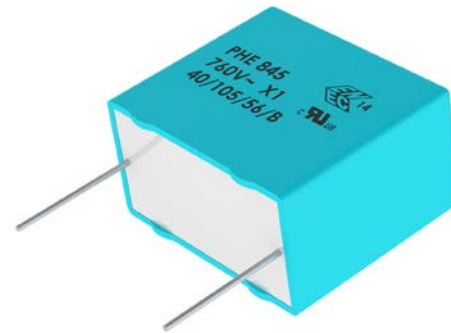

Customer Part Number

| PHE845 | V | D | 5100 | M | R06L2 |
|------------------------------|---------------------|----------------------------------|--|--------------------------------|----------------------------|
| Series | Rated Voltage (VAC) | Lead Spacing (mm) | Capacitance Code (pF) | Capacitance Tolerance | Packaging |
| X1, Metallized Polypropylene | V = 760 | D = 22.5 F = 27.5 R = 37.5 | The last three digits represent significant figures. The first digit specifies the total number of digits. | K = \pm 10% M = \pm 20% | See Ordering Options Table |

KEMET Internal Part Number

| F | 845 | D | D | 103 | M | 760 | C |
|-----------------|------------------------------|----------------------------------|---------------------|--|--------------------------------|---------------------|----------------------------|
| Capacitor Class | Series | Lead Spacing (mm) | Size Code | Capacitance Code (pF) | Capacitance Tolerance | Rated Voltage (VAC) | Packaging |
| F = Film | X1, Metallized Polypropylene | D = 22.5 F = 27.5 R = 37.5 | See Dimension Table | First two digits represent significant figures. Third digit specifies number of zeros. | K = \pm 10% M = \pm 20% | 760 = 760 | See Ordering Options Table |

Ordering Options Table

| Lead Spacing Nominal (mm) | Type of Leads and Packaging | Lead Length (mm) | KEMET Lead and Packaging Code | Legacy Lead and Packaging Code |
|---------------------------|--|----------------------------|-------------------------------|--------------------------------|
| 22.5 | Standard Lead and Packaging Options | | | |
| | Bulk (Tray)–Short Leads | 6 +0/-1 | C | R06L2 ⁽¹⁾ |
| | Other Lead and Packaging Options | | | |
| | Pizza Pack | 6 +0/-1 | Z | R06L2 ⁽¹⁾ |
| | Bulk (Tray)–Long Leads | 30 +5/-0 | ALW0L | R30L2 |
| | Tape & Reel (Standard Reel) | H ₀ = 18.5 ±0.5 | L | R17T0 |
| | Tape & Reel (Large Reel) | H ₀ = 18.5 ±0.5 | P | R17T1 |
| 27.5 | Standard Lead and Packaging Options | | | |
| | Bulk (Tray)–Short Leads | 6 +0/-1 | C | R06L2 ⁽¹⁾ |
| | Other Lead and Packaging Options | | | |
| | Pizza Pack | 6 +0/-1 | Z | R06L2 ⁽¹⁾ |
| | Bulk (Tray)–Long Leads | 30 +5/-0 | ALW0L | R30L2 |
| | Tape & Reel (Large Reel) | H ₀ = 18.5 ±0.5 | P | R17T1 |
| 37.5 | Standard Lead and Packaging Options | | | |
| | Bulk (Tray)–Short Leads | 6 +0/-1 | C | R06L2 ⁽¹⁾ |
| | Other Lead and Packaging Options | | | |
| | Pizza Pack | 6 +0/-1 | Z | R06L2 ⁽¹⁾ |

(1) Please specify Bulk (Tray) or Pizza Packaging

Dimensions – Millimeters

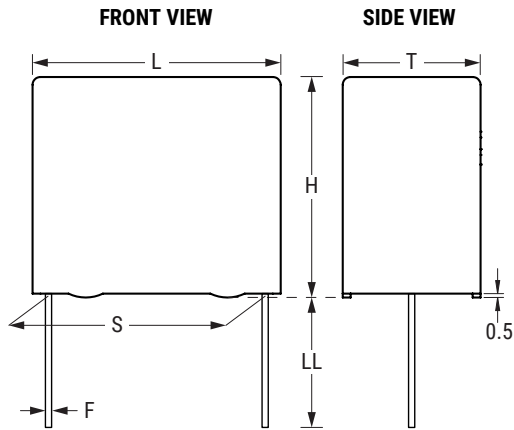

| KEMET Size Code | Legacy Size Code | S | | T | | H | | L | | F | |
|-----------------|------------------|---------|-----------|---------|-----------|---------|-----------|---------|-----------|---------|-----------|
| | | Nominal | Tolerance | Nominal | Tolerance | Nominal | Tolerance | Nominal | Tolerance | Nominal | Tolerance |
| DD | D13 | 22.5 | ±0.4 | 6.5 | Maximum | 14.5 | Maximum | 26.0 | Maximum | 0.8 | ±0.05 |
| DG | D17 | 22.5 | ±0.4 | 7.0 | Maximum | 16.5 | Maximum | 26.0 | Maximum | 0.8 | ±0.05 |
| DM | D15 | 22.5 | ±0.4 | 9.0 | Maximum | 18.5 | Maximum | 26.0 | Maximum | 0.8 | ±0.05 |
| DR | D18 | 22.5 | ±0.4 | 10.5 | Maximum | 19.0 | Maximum | 26.0 | Maximum | 0.8 | ±0.05 |
| DT | D16 | 22.5 | ±0.4 | 11.0 | Maximum | 21.5 | Maximum | 26.0 | Maximum | 0.8 | ±0.05 |
| DW | D20 | 22.5 | ±0.4 | 13.5 | Maximum | 23.0 | Maximum | 26.0 | Maximum | 0.8 | ±0.05 |
| DY | D19 | 22.5 | ±0.4 | 15.5 | Maximum | 24.5 | Maximum | 26.0 | Maximum | 0.8 | ±0.05 |
| FE | F11 | 27.5 | ±0.4 | 10.5 | Maximum | 20.5 | Maximum | 31.5 | Maximum | 0.8 | ±0.05 |
| FG | F12 | 27.5 | ±0.4 | 11.5 | Maximum | 22.5 | Maximum | 31.5 | Maximum | 0.8 | ±0.05 |
| FK | F03 | 27.5 | ±0.4 | 13.5 | Maximum | 23.0 | Maximum | 31.5 | Maximum | 0.8 | ±0.05 |
| FS | F15 | 27.5 | ±0.4 | 19.0 | Maximum | 29.0 | Maximum | 31.5 | Maximum | 0.8 | ±0.05 |
| FV | F16 | 27.5 | ±0.4 | 21.0 | Maximum | 30.0 | Maximum | 31.5 | Maximum | 0.8 | ±0.05 |
| RH | R04 | 37.5 | ±0.5 | 15.0 | Maximum | 26.0 | Maximum | 41.0 | Maximum | 1.0 | ±0.05 |
| RK | R02 | 37.5 | ±0.5 | 16.5 | Maximum | 32.0 | Maximum | 41.0 | Maximum | 1.0 | ±0.05 |
| RM | R03 | 37.5 | ±0.5 | 19.0 | Maximum | 36.0 | Maximum | 41.0 | Maximum | 1.0 | ±0.05 |
| RP | R06 | 37.5 | ±0.5 | 21.0 | Maximum | 38.0 | Maximum | 41.0 | Maximum | 1.0 | ±0.05 |

Note: See the Ordering Options Table for lead length (LL) options.



Performance Characteristics

| | | | |
|-------------------------------------|--|---|--|
| Dielectric | Polypropylene film | | |
| Plates | Metal layer deposited by evaporation under vacuum | | |
| Winding | Non-inductive type. Triple design. | | |
| Leads | Tinned wire | | |
| Protection | Plastic case, thermosetting resin-filled. Box material is solvent-resistant and flame-retardant according to UL94 V-0. | | |
| Rated Voltage (V_R) | 760 VAC 50/60 Hz | | |
| Capacitance Range | 0.010 – 1.0 μ F | | |
| Capacitance Values | E6 series (IEC 60063) | | |
| Capacitance Tolerance | \pm 20% standard, \pm 10% option | | |
| Temperature Range | -40°C to 105°C | | |
| Climatic Category | 40/105/56/B IEC 60068-1 | | |
| Approvals | ENEC, UL, cUL | | |
| Related Documents | EN/IEC 60384-14:2005, UL 60384-14, CAN/CSA E60384-14:09 | | |
| Dissipation Factor ($\tan\delta$) | Maximum Values at +23°C | | |
| | Frequency | $C \leq 0.1 \mu\text{F}$ | $0.1 \mu\text{F} < C \leq 1 \mu\text{F}$ |
| | 1 kHz | 0.1% | 0.1% |
| | 10 kHz | 0.2% | 0.4% |
| | 100 kHz | 0.6% | - |
| Test Voltage Between Terminals | The 100% screening factory test is carried out at 4,250 VDC. The voltage level is selected to meet the requirements in applicable equipment standards. All electrical characteristics are checked after the test. It is not permitted to repeat this test as there is a risk to damage the capacitor. KEMET is not liable in such case for any failures. | | |
| Resonance Frequency | Tabulated self-resonance frequencies f_o (see Table 1 – Ratings & Part Number Reference) | | |
| Insulation Resistance | Measured at +25°C \pm 5°C, according to IEC 60384-2 | | |
| | Minimum Values Between Terminals | | |
| | $C \leq 0.33 \mu\text{F}$ | $C > 0.33 \mu\text{F}$ | |
| | $\geq 30,000 \text{ M}\Omega$ | $\geq 10,000 \text{ M}\Omega \cdot \mu\text{F}$ | |
| In DC Applications | Recommended voltage \leq 1,500 VDC | | |

Environmental Test Data

| Test | IEC Publication | Procedure |
|------------------------|-------------------------|--|
| Endurance | IEC 60384-14:2005 | 1.25 x V _R VAC 50 Hz, once every hour increase to 1,000 VAC for 0.1 second, 1,000 hours at upper rated temperature |
| Vibration | IEC 60068-2-6 Test Fc | 3 directions at 2 hours each 10 – 55 Hz at 0.75 mm or 98 m/s ² No visible damage. No open or short circuit. |
| Bump | IEC 60068-2-29 Test Eb | 1,000 bumps at 390 m/s ² No visible damage. No open or short circuit. |
| Change of Temperature | IEC 60068-2-14 Test Na | Upper and lower rated temperature 5 cycles No visible damage. |
| Active Flammability | IEC 60384-14:2005 | V _R + 20 surge pulses at 4 kV (pulse every 5 seconds) |
| Passive Flammability | IEC 60384-14:2005 | IEC 60384-1, IEC 60695-11-5 Needle Flame Test |
| Damp Heat Steady State | IEC 60068-2-78 Test Cab | +40°C and 90 – 95% RH, 56 days |
| THB Test | According to Grade IA | +40°C and 90 - 95% RH, 21 days at rated AC-voltage Capacitance change ($\Delta C/C$): $\leq 10\%$ Dissipation factor change ($\Delta \tan \delta$): $\leq 24 * 10^{-3}$ (at 10 kHz) for C $\leq 1 \mu F$ Dissipation factor change ($\Delta \tan \delta$): $\leq 15 * 10^{-3}$ (at 1 kHz) for C $> 1 \mu F$ Insulation resistance IR in seconds or time constant $\tau = CR$ Rins: $\geq 50\%$ of initial limit |

Approvals

| Certification Body | Mark | Specification | File Number |
|--------------------|---|---|-------------|
| Intertek Semko AB |  | EN/IEC 60384-14 | SE/0140-17E |
| UL |  | UL 60384 and CAN/CSA E60384-14:09 (760 VAC) | E73869 |

Environmental Compliance

All KEMET EMI capacitors are RoHS compliant.



Table 1 – Ratings & Part Number Reference

| Capacitance Value (µF) | Size Code (KEMET/Legacy) | Maximum Dimensions in mm | | | Lead Spacing (S) | f _o (MHz) | dV/dt (V/µs) | KEMET Part Number | Legacy Part Number |
|------------------------|--------------------------|--------------------------|--------|--------|------------------|----------------------|--------------|--------------------|--------------------|
| | | T | H | L | | | | | |
| 0.010 | DD/D13 | 6.5 | 14.5 | 26.0 | 22.5 | 11 | 100 | F845DD103(1)760(2) | PHE845VD5100(1)(2) |
| 0.015 | DD/D13 | 6.5 | 14.5 | 26.0 | 22.5 | 9.2 | 100 | F845DD153(1)760(2) | PHE845VD5150(1)(2) |
| 0.022 | DD/D13 | 6.5 | 14.5 | 26.0 | 22.5 | 7.6 | 100 | F845DD223(1)760(2) | PHE845VD5220(1)(2) |
| 0.033 | DF/D17 | 7.0 | 16.5 | 26.0 | 22.5 | 6.4 | 100 | F845DF333(1)760(2) | PHE845VD5330(1)(2) |
| 0.047 | DM/D15 | 9.0 | 18.5 | 26.0 | 22.5 | 5.3 | 100 | F845DM473(1)760(2) | PHE845VD5470(1)(2) |
| 0.068 | DR/D18 | 10.5 | 19.0 | 26.0 | 22.5 | 4.4 | 100 | F845DR683(1)760(2) | PHE845VD5680(1)(2) |
| 0.10 | DT/D16 | 11.0 | 21.5 | 26.0 | 22.5 | 3.5 | 100 | F845DT104(1)760(2) | PHE845VD6100(1)(2) |
| 0.15 | DW/D20 | 13.5 | 23.0 | 26.0 | 22.5 | 3.1 | 100 | F845DW154(1)760(2) | PHE845VD6150(1)(2) |
| 0.22 | DY/D19 | 15.5 | 24.5 | 26.0 | 22.5 | 2.7 | 100 | F845DY224M760(2) | PHE845VY6220M(2) |
| 0.10 | FE/F11 | 10.5 | 20.5 | 31.5 | 27.5 | 3.4 | 100 | F845FE104(1)760(2) | PHE845VF6100(1)(2) |
| 0.15 | FG/F12 | 11.5 | 22.5 | 31.5 | 27.5 | 3.0 | 100 | F845FG154(1)760(2) | PHE845VF6150(1)(2) |
| 0.22 | FK/F03 | 13.5 | 23.0 | 31.5 | 27.5 | 2.4 | 100 | F845FK224(1)760(2) | PHE845VF6220(1)(2) |
| 0.33 | FS/F15 | 19.0 | 29.0 | 31.5 | 27.5 | 2.0 | 100 | F845FS334(1)760(2) | PHE845VF6330(1)(2) |
| 0.47 | FV/F16 | 21.0 | 30.0 | 31.5 | 27.5 | 1.6 | 100 | F845FV474M760(2) | PHE845VZ6470M(2) |
| 0.47 | RH/R04 | 15.0 | 26.0 | 41.0 | 37.5 | 1.6 | 100 | F845RH474M760(2) | PHE845VW6470M(2) |
| 0.47 | RK/R02 | 16.5 | 32.0 | 41.0 | 37.5 | 1.6 | 100 | F845RK474(1)760(2) | PHE845VR6470(1)(2) |
| 0.68 | RM/R03 | 19.0 | 36.0 | 41.0 | 37.5 | 1.2 | 100 | F845RM684(1)760(2) | PHE845VR6680(1)(2) |
| 1.0 | RP/R06 | 21.0 | 38.0 | 41.0 | 37.5 | 1.0 | 100 | F845RP105M760(2) | PHE845VW7100M(2) |
| Capacitance Value (µF) | Size Code (KEMET/Legacy) | T (mm) | H (mm) | L (mm) | Lead Spacing (S) | f _o (MHz) | dV/dt (V/µs) | KEMET Part Number | Legacy Part Number |

(1) M = ±20%, K = ±10%.

(2) Insert ordering code for lead type and packaging. See the Ordering Options Table for available options.

Soldering Process

The implementation of the RoHS directive has resulted in the selection of SnAuCu (SAC) alloys or SnCu alloys as primary solder. This implementation has increased the liquidus temperature from 183°C for SnPb eutectic alloys to 217 – 221°C for the new alloys. As a result, the heat stress to the components, even in wave soldering, has increased considerably due to higher pre-heat and wave temperatures. Polypropylene capacitors are especially sensitive to heat (the melting point of polypropylene is 160 – 170°C). Wave soldering can be destructive, especially for mechanically small polypropylene capacitors (with lead spacing of 5 – 15 mm), and great care must be taken during soldering. The recommended solder profiles from KEMET should be used. Consult KEMET with any questions. In general, the wave soldering curve from IEC Publication 61760-1 Edition 2 serves as a solid guideline for successful soldering. See Figure 1.

Reflow soldering is not recommended for through-hole film capacitors. Exposing capacitors to a soldering profile in excess of the recommended limits may result in degradation of or permanent damage to the capacitors.

Do not place the polypropylene capacitor through an adhesive curing oven to cure resin for surface-mount components. Insert through-hole parts after curing the surface mount parts. Consult KEMET to discuss the actual temperature profile in the oven, if through-hole components must pass through the adhesive curing process. A maximum of two soldering cycles is recommended. Allow time for the capacitor surface temperature to return to normal before the second soldering cycle.

Manual Soldering Recommendations

Following is the recommendation for manual soldering with a soldering iron.

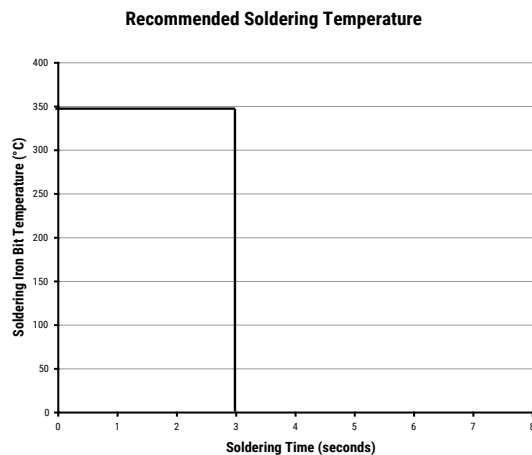

Soldering iron tip temperature should be set at 350°C (+10°C maximum), with the soldering duration not to exceed 3 seconds.

Wave Soldering Recommendations

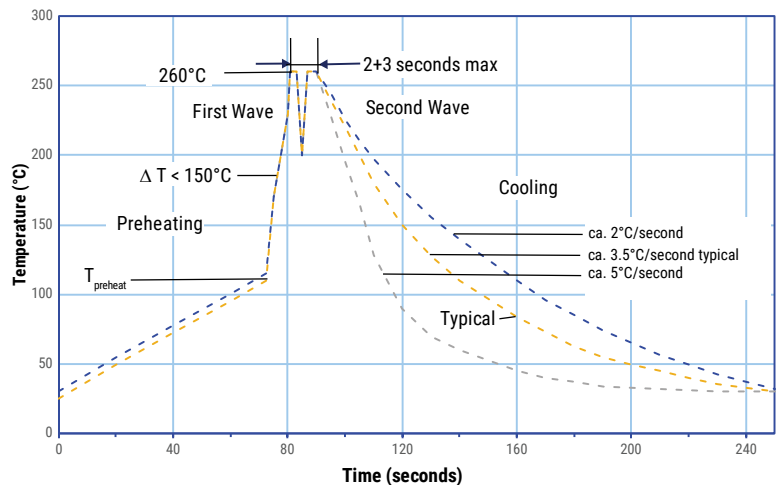

Soldering Process cont.

Wave Soldering Recommendations cont.

1. The table indicates the maximum set-up temperature of the soldering process.
 Figure 1

| Dielectric film material | Maximum Preheat Temperature | | Maximum Peak Soldering Temperature | |
|--------------------------|-----------------------------|-------------------------|------------------------------------|-------------------------|
| | Capacitor Pitch ≥ 10 mm | Capacitor Pitch > 15 mm | Capacitor Pitch ≤ 15 mm | Capacitor Pitch > 15 mm |
| Polyester | 130°C | 130°C | 270°C | 270°C |
| Polypropylene | 110°C | 130°C | 260°C | 270°C |
| Paper | 130°C | 140°C | 270°C | 270°C |
| Polyphenylene Sulphide | 150°C | 160°C | 270°C | 270°C |

2. The maximum temperature measured inside the capacitor: set the temperature so that the maximum temperature is below the limit inside the element.

| Dielectric Film Material | Maximum Temperature Measured Inside the Element |
|--------------------------|---|
| Polyester | 160°C |
| Polypropylene | 110°C |
| Paper | 160°C |
| Polyphenylene Sulphide | 160°C |

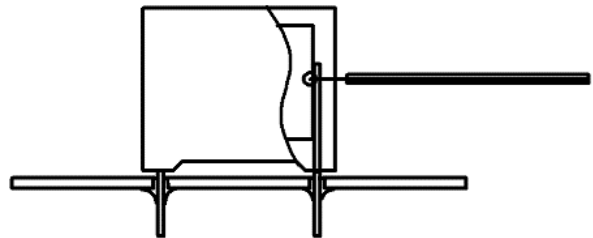

Temperature monitored inside the capacitor.

Selective Soldering Recommendations

Selective dip soldering is a variation of reflow soldering. In this method, the printed circuit board with through-hole components to be soldered is preheated and transported over the solder bath, as in normal flow soldering, without touching the solder. When the board is over the bath, it is stopped. Pre-designed solder pots are lifted from the bath with molten solder only at the places of the selected components, and then pressed against the lower surface of the board to solder the components.

The temperature profile for selective soldering is similar to the double-wave flow soldering outlined in this document. **However, instead of two baths, there is only one with a time from 3 to 10 seconds.** In selective soldering, the risk of overheating is greater than in double-wave flow soldering. Great care must be taken so that the parts do not overheat.

Construction

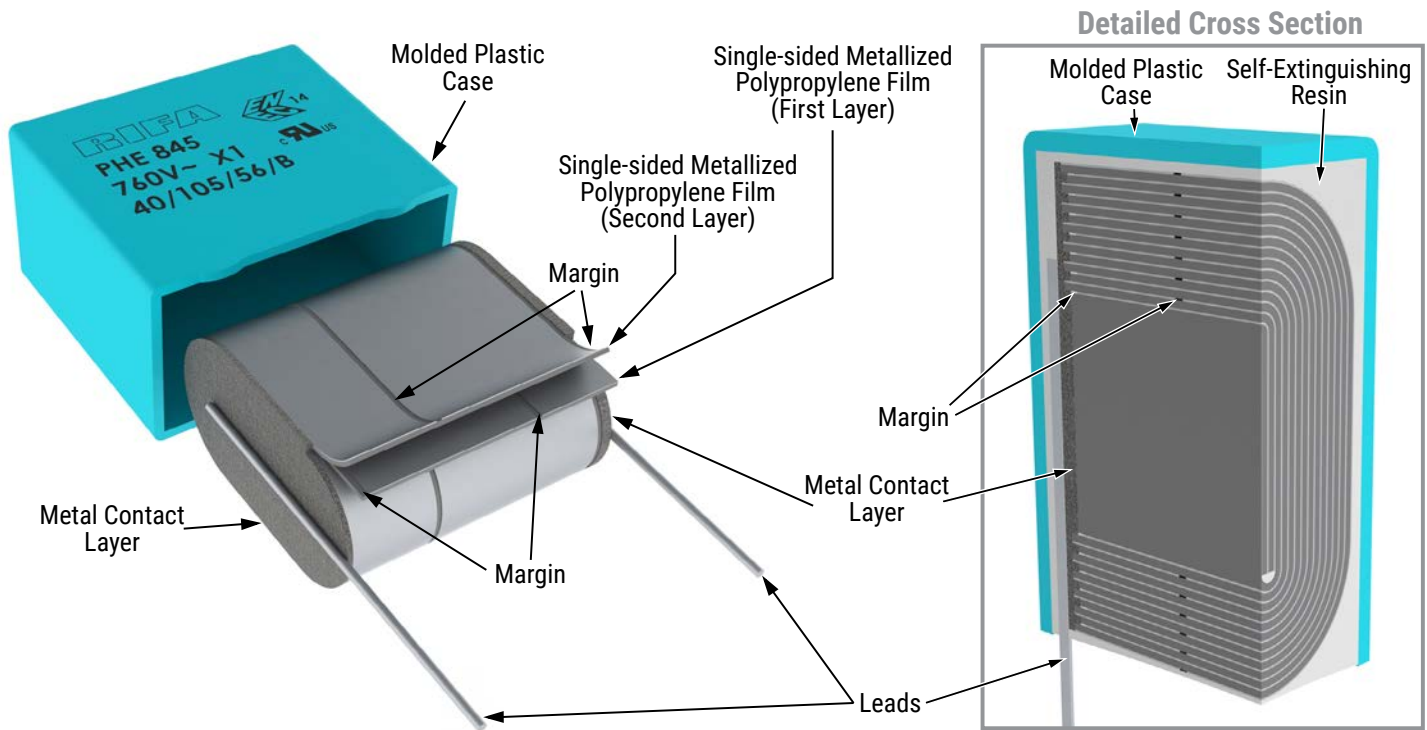

Winding Scheme

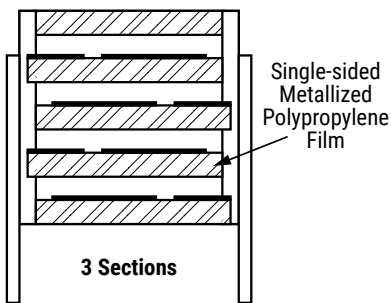

Marking

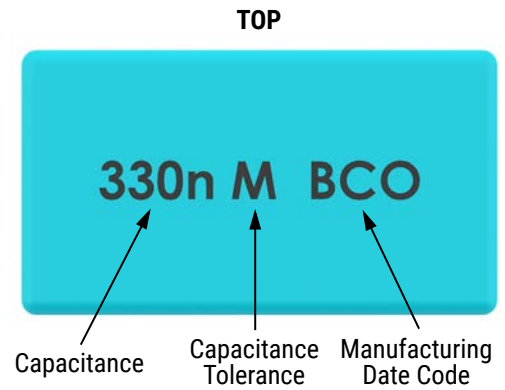
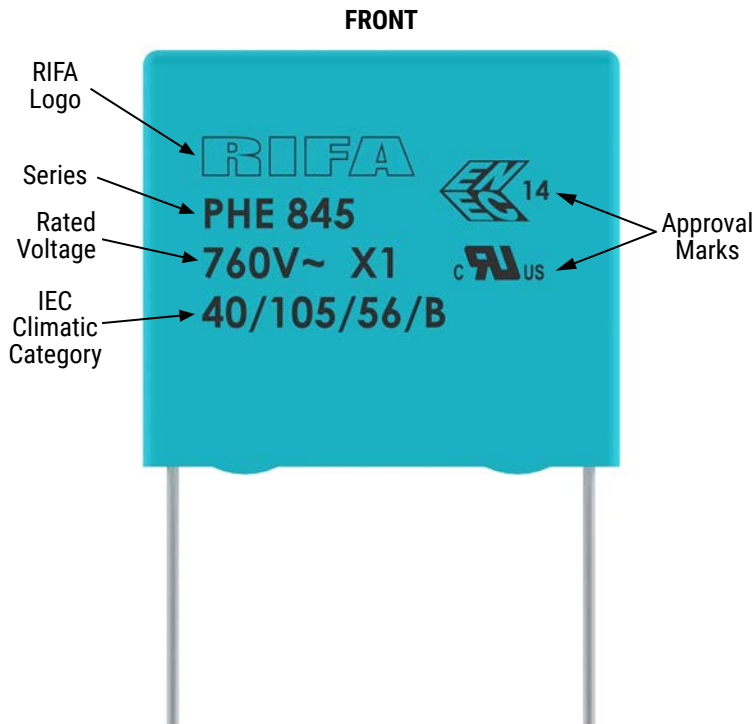

Manufacturing Date Code (IEC-60062)

| Year | Code | Month | Code |
|------|------|-----------|------|
| 2010 | A | January | 1 |
| 2011 | B | February | 2 |
| 2012 | C | March | 3 |
| 2013 | D | April | 4 |
| 2014 | E | May | 5 |
| 2015 | F | June | 6 |
| 2016 | H | July | 7 |
| 2017 | J | August | 8 |
| 2018 | K | September | 9 |
| 2019 | L | October | 0 |
| 2020 | M | November | N |
| 2021 | N | December | D |
| 2022 | P | | |
| 2023 | R | | |
| 2024 | S | | |
| 2025 | T | | |
| 2026 | U | | |
| 2027 | V | | |
| 2028 | W | | |
| 2029 | X | | |
| 2030 | A | | |

Packaging Quantities

| Lead Spacing | KEMET Size Code | Legacy Size Code | Thickness (mm) | Height (mm) | Length (mm) | Bulk Short Leads | Standard Reel ø 355 mm | Large Reel ø 500 mm | Ammo Bulk (Pizza) |
|--------------|-----------------|------------------|----------------|-------------|-------------|------------------|---------------------------|------------------------|-------------------|
| 22.5 | DD | D13 | 6.5 | 14.5 | 26.0 | 234 | 300 | 600 | 440 |
| | DH | D14 | 8.0 | 16.0 | 26.0 | 186 | 250 | 500 | 352 |
| | DM | D15 | 9.0 | 18.5 | 26.0 | 308 | 250 | 500 | 308 |
| | DT | D16 | 11.0 | 21.5 | 26.0 | 253 | 200 | 400 | 253 |
| | DF | D17 | 7.0 | 16.5 | 26.0 | 216 | 300 | 600 | 396 |
| | DR | D18 | 10.5 | 19.0 | 26.0 | 264 | 200 | 400 | 264 |
| | DY | D19 | 15.5 | 24.5 | 26.0 | 176 | 110 | 250 | 176 |
| | DW | D20 | 13.5 | 23.0 | 26.0 | 209 | 160 | 300 | 209 |
| 27.5 | FK | F03 | 13.5 | 23.0 | 31.5 | 171 | | 250 | 171 |
| | FE | F11 | 10.5 | 20.5 | 31.5 | 216 | | 350 | 216 |
| | FG | F12 | 11.5 | 22.5 | 31.5 | 198 | | 300 | 198 |
| | FM | F13 | 14.5 | 24.5 | 31.5 | 153 | | 250 | 153 |
| | FR | F14 | 17.5 | 28.0 | 31.5 | 126 | | | 126 |
| | FS | F15 | 19.0 | 29.0 | 31.5 | 117 | | | 117 |
| | FV | F16 | 21.0 | 30.0 | 31.5 | 108 | | | 108 |
| | FH | F17 | 21.0 | 12.5 | 31.5 | 108 | | | 108 |
| | FT | F18 | 31.0 | 18.5 | 31.5 | 72 | | | 72 |
| | FQ | F19 | 27.5 | 16.0 | 31.5 | 81 | | | 81 |
| 37.5 | RK | R02 | 16.5 | 32.0 | 41.0 | 105 | | | 105 |
| | RM | R03 | 19.0 | 36.0 | 41.0 | 91 | | | 91 |
| | RH | R04 | 15.0 | 26.0 | 41.0 | 119 | | | 119 |
| | RF | R05 | 13.0 | 24.0 | 41.0 | 140 | | | 140 |
| | RP | R06 | 21.0 | 38.0 | 41.0 | 84 | | | 84 |
| | RS | R08 | 28.0 | 43.0 | 41.0 | 54 | | | 54 |

Lead Taping & Packaging (IEC 60286-2)

Lead Spacing 22.5 – 27.5 mm

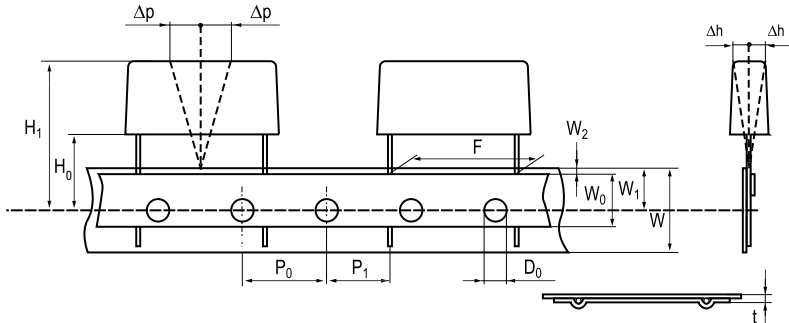

Taping Specification

| Description | Symbol | Dimensions (mm) | | |
|--------------------------------------|--------------------|-----------------|------|------------|
| | | Lead Space | | Tolerance |
| | | 22.5 | 27.5 | |
| Lead Spacing | F | 22.5 | 27.5 | +0.6/-0.1 |
| Carrier Tape Width | W | 18 | 18 | +1/-0.5 |
| Hold Down Tape Width | W ₀ | 5 | 5 | Minimum |
| Hole Position | W ₁ | 9 | 9 | +0.75/-0.5 |
| Hold Down Tape Position | W ₂ | 3 | 3 | Maximum |
| Feed Hole Diameter | D ₀ | 4 | 4 | ±0.2 |
| Feed-hole Lead Space * | P ₀ | 12.7 | 12.7 | ±0.2 ** |
| Centering of the Lead Wire | P ₁ | 7.8 | 5.3 | ±0.7 |
| Component Alignment | Δh | 2 | 2 | ±2 |
| Deviation Tape – Plane | Δp | 1.3 | 1.3 | Maximum |
| Tape Thickness | t | 0.9 | 0.9 | Maximum |
| Height of Component from Tape Center | H ₀ *** | 18.5 | 18.5 | ±0.5 |

*Available also 15mm

**Maximum 1 mm on 20 lead spaces

*** H₀ = 16.5 mm is available upon request

KEMET Electronics Corporation Sales Offices

For a complete list of our global sales offices, please visit www.kemet.com/sales.

Disclaimer

YAGEO Corporation and its affiliates do not recommend the use of commercial or automotive grade products for high reliability applications or manned space flight.

All product specifications, statements, information and data (collectively, the "Information") in this datasheet are subject to change. The customer is responsible for checking and verifying the extent to which the Information contained in this publication is applicable to an order at the time the order is placed. All Information given herein is believed to be accurate and reliable, but it is presented without guarantee, warranty, or responsibility of any kind, expressed or implied.

Statements of suitability for certain applications are based on KEMET Electronics Corporation's ("KEMET") knowledge of typical operating conditions for such applications, but are not intended to constitute – and KEMET specifically disclaims – any warranty concerning suitability for a specific customer application or use. The Information is intended for use only by customers who have the requisite experience and capability to determine the correct products for their application. Any technical advice inferred from this Information or otherwise provided by KEMET with reference to the use of KEMET's products is given gratis, and KEMET assumes no obligation or liability for the advice given or results obtained.

Although KEMET designs and manufactures its products to the most stringent quality and safety standards, given the current state of the art, isolated component failures may still occur. Accordingly, customer applications which require a high degree of reliability or safety should employ suitable designs or other safeguards (such as installation of protective circuitry or redundancies) in order to ensure that the failure of an electrical component does not result in a risk of personal injury or property damage.

Although all product-related warnings, cautions and notes must be observed, the customer should not assume that all safety measures are indicated or that other measures may not be required.

Additional information about production site flexibility can be found [here](#)