



TAOGLAS®



Datasheet

2.4GHz High Efficiency Loop Antenna

Part No:
WLA.01

Description

2400MHz to 2500MHz WLAN/Wi-Fi/Bluetooth

Features:

3.2*1.6*0.5mm
Low Profile
Peak gain 1dBi typ
50 Ohm Impedance
CE Certified
RoHS and REACH Compliant

1.	Introduction	3
2.	Specification	5
3.	Antenna Characteristics	6
4.	Radiation Patterns	10
5.	Mechanical Drawing	14
6.	Antenna Integration Guide	15
7.	Solder Reflow Profile	25
8.	Packaging	26
9.	Application Note	27
<hr/>		
	Changelog	37

Taoglas makes no warranties based on the accuracy or completeness of the contents of this document and reserves the right to make changes to specifications and product descriptions at any time without notice. Taoglas reserves all rights to this document and the information contained herein. Reproduction, use or disclosure to third parties without express permission is strictly prohibited.

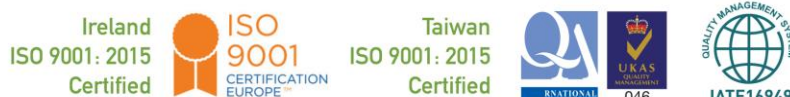

1. Introduction



The WLA.01 2.4GHz Loop antenna is a high efficiency, miniature SMD, edge mounted ceramic antenna for very small space requirements for Wi-Fi, WLAN, Zigbee, Bluetooth, and 802.11 applications. The WLA.01 uses the main PCB as its ground plane, thereby increasing Antenna Efficiency. It is tuned for different PCB sizes by simply changing the value of the matching circuit. At 3.2mm*1.6mm*0.5mm, the WLA.01 is one of the smallest antennas available worldwide. This antenna is delivered on tape and Reel.

Upon testing of any of our antennas with your device and a selection of appropriate layout, integration technique, or cable, Taoglas can make sure any of our antennas' peak gain will be below the peak gain limits. Taoglas can then issue a specification and/or report for the selected antenna in your device that will clearly show it complying with the peak gain limits, so you can be assured you are meeting regulatory requirements for that module.

For example, a module manufacturer may state that the antenna must have less than 2dBi peak gain, but you don't need to select an embedded antenna that has a peak gain of less than 2dBi in free-space. This will give you a less optimized solution. It is better to go for a slightly higher free-space peak gain of 3dBi or more if available. Once that antenna gets integrated into your device, performance will degrade below this 2dBi peak gain due to the effects of GND plane, surrounding components, and device housing. If you want to be absolutely sure, contact Taoglas and we will test. Choosing a Taoglas antenna with a higher peak gain than what is specified by the module manufacturer and enlisting our help will ensure you are getting the best performance possible without exceeding the peak gain limits.

This antenna can be mounted with no performance degradation in either orientation as long as the antenna is soldered correctly via Surface mounting. Please see the integration instructions section for further detail regarding the optimum way to integrate this antenna into your device.

The WLA.01 is designed to mount at the center of the edge of an evaluation board of 80 x 40mm. The antenna performance was measured with the WLA.01 mounted on the evaluation board with SMA(F) connector.

Typical Applications Include:

- Bluetooth earphone systems
- Hand-held devices when Bluetooth/Wi-Fi functions are needed, e.g., Smart phone.
- IEEE802.11 b/g
- ZigBee
- Wireless PCMCIA cards or USB dongle

For further optimization to customer-specific device environments and for support to integrate and test this antennas performance in your device, contact your regional Taoglas Customer Services Team.

Our Taoglas Taiwan Tainan is our primary manufacturing and engineering site and houses a significant portion of our operations workforce including manufacturing, test, failure analysis, purchasing, production planning, and quality. Located in an international science park in the Sinshih District, our growing facility and team of experts ensures fast regional response times and global operational excellence in manufacturing services.

Address: Taoglas Manufacturing Site, 4F-2, No.15, Guoji Road, Xinshi District, Tainan City 744, Taiwan (R.O.C.)
Contact: +886 3 3681223

2. Specification

Wi-Fi Electrical								
Band	Frequency (MHz)	Efficiency (%)	Average Gain (dB)	Peak Gain (dBi)	Impedance	VSWR	Radiation Pattern	Max. input power
Wi-Fi 2.4GHz	2400-2500	67.8	-1.69	1.0	50 Ω	2Max	Omni	5W

Mechanical	
Dimensions	3.2*1.6*0.5mm
Material	Ceramic

Environmental	
Operating Temperature	-40°C~+85°C
Storage Temperature	-40°C~+105°C
Temperature Coefficient (τ_f)	0 \pm 20 ppm @ -20°C to +80°C
Recommended Reel Storage Condition	5°C to 40°C Relative Humidity 20% to 70%
Moisture Sensitivity Level (MSL)	3 (168 Hours)

3. Antenna Characteristics

3.1 Test Setup

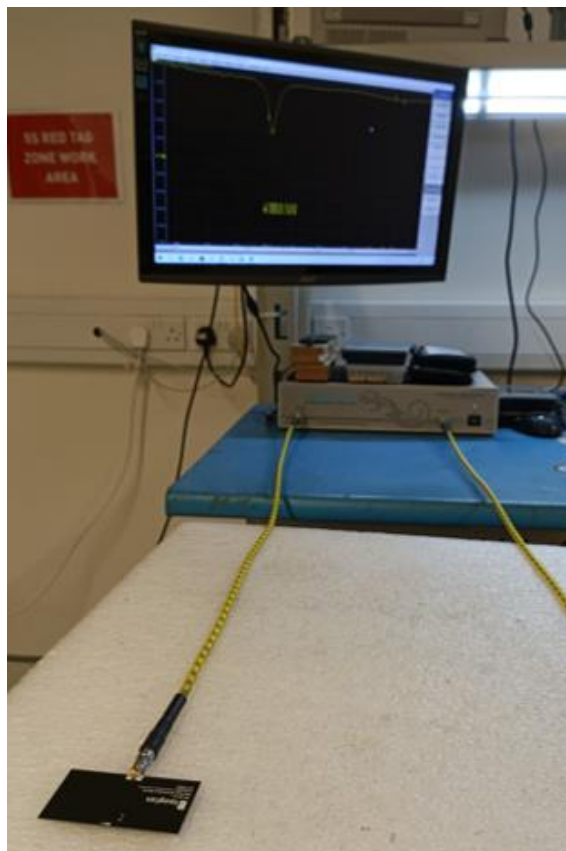
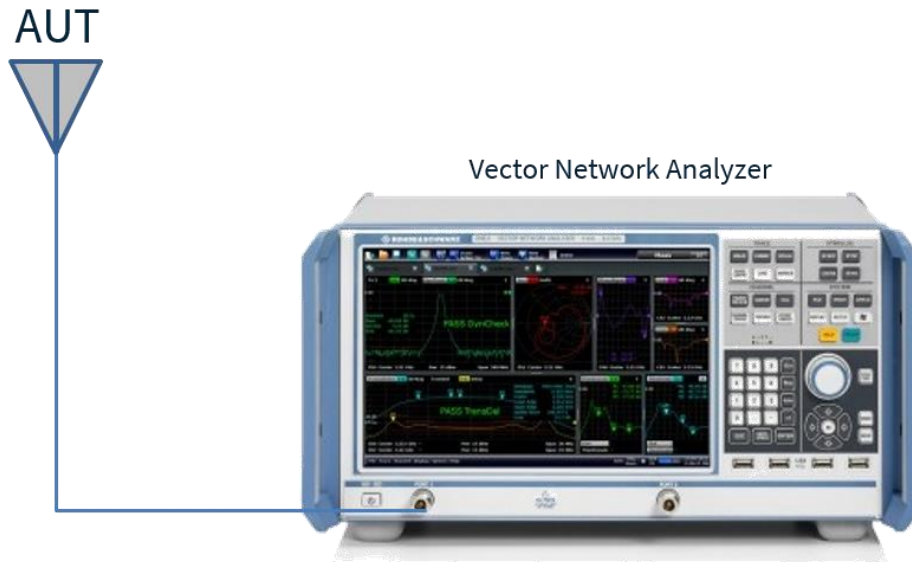

3.2 Return Loss

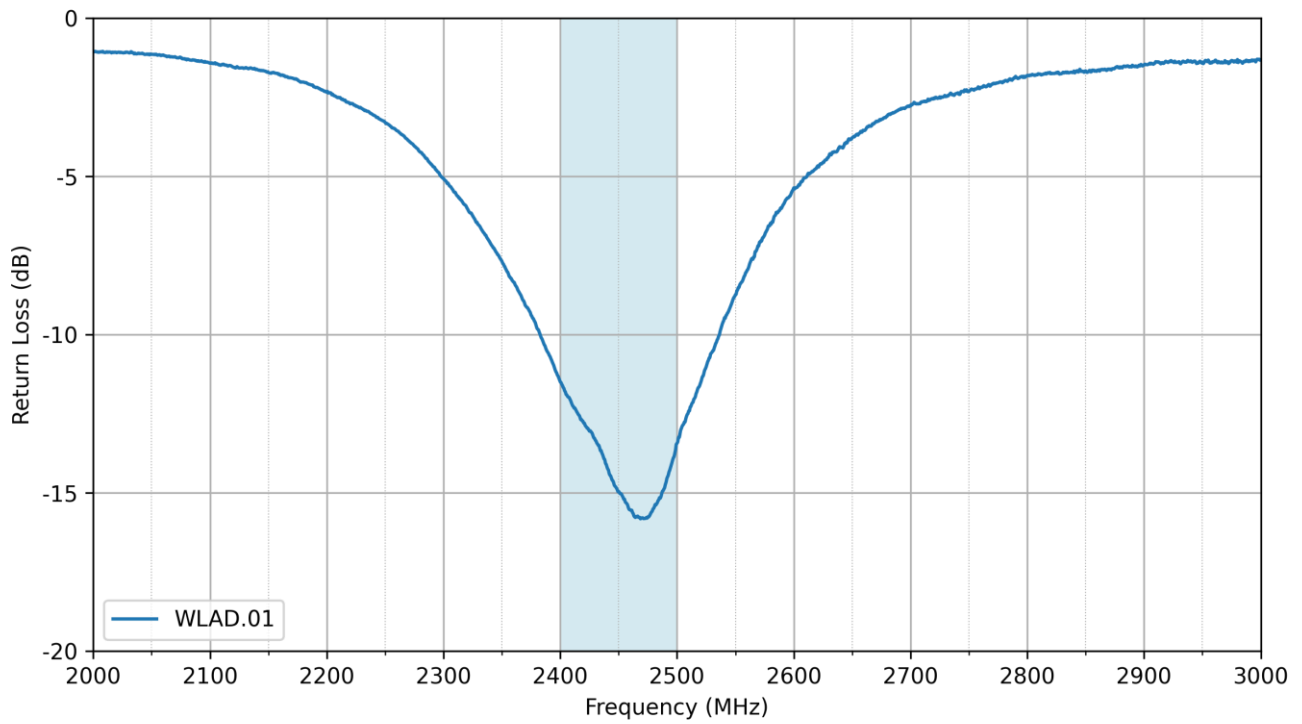

3.3 VSWR

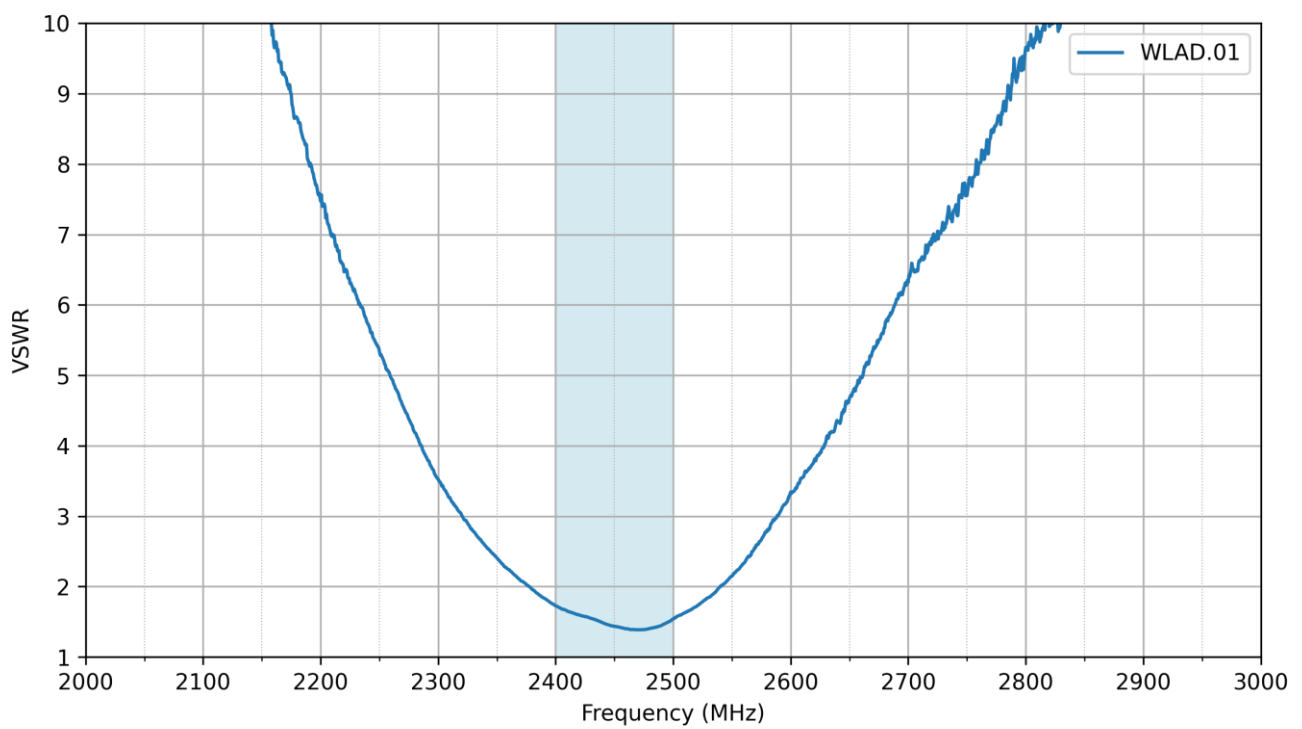

3.4 Efficiency

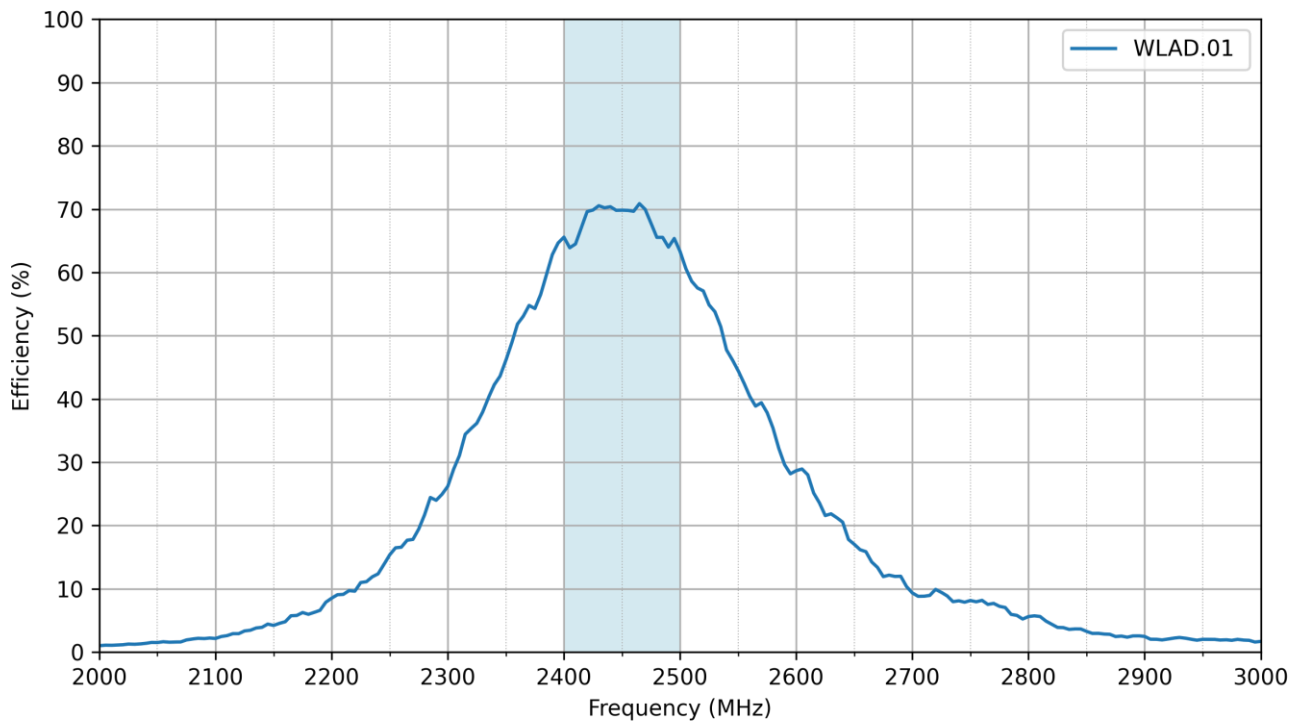

3.5 Average Gain

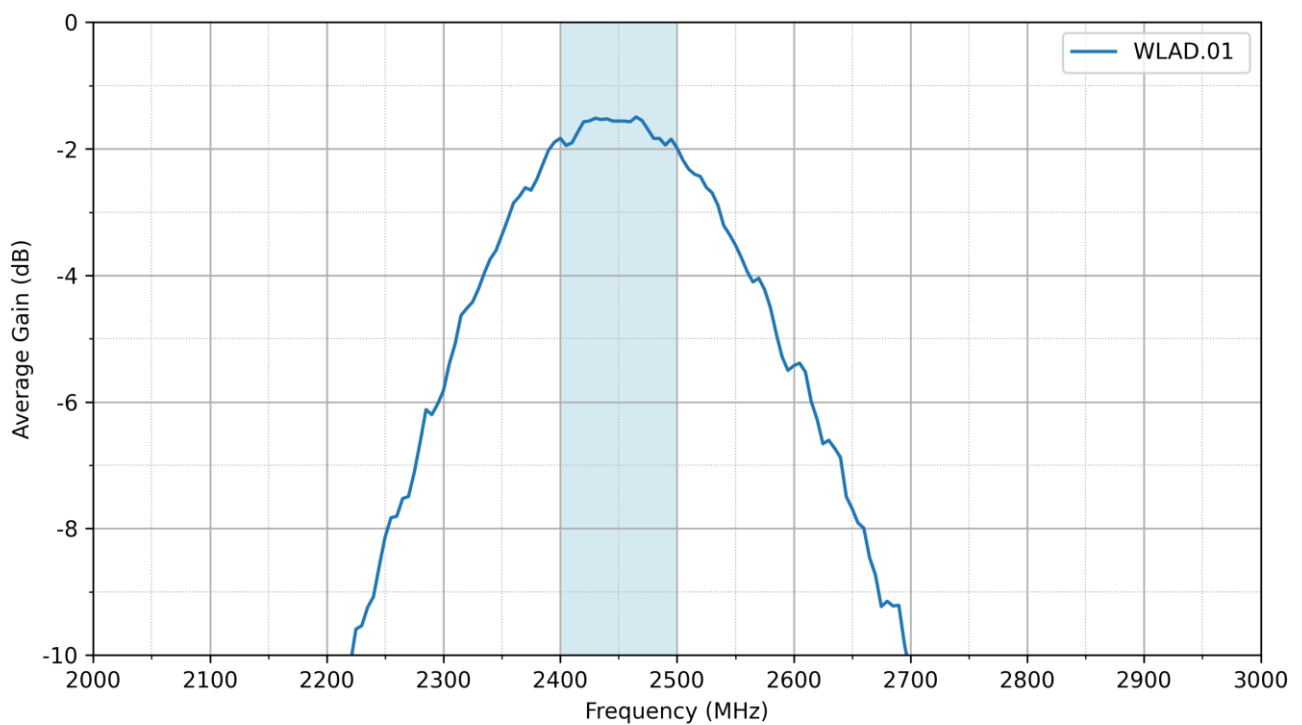

3.6 Peak Gain

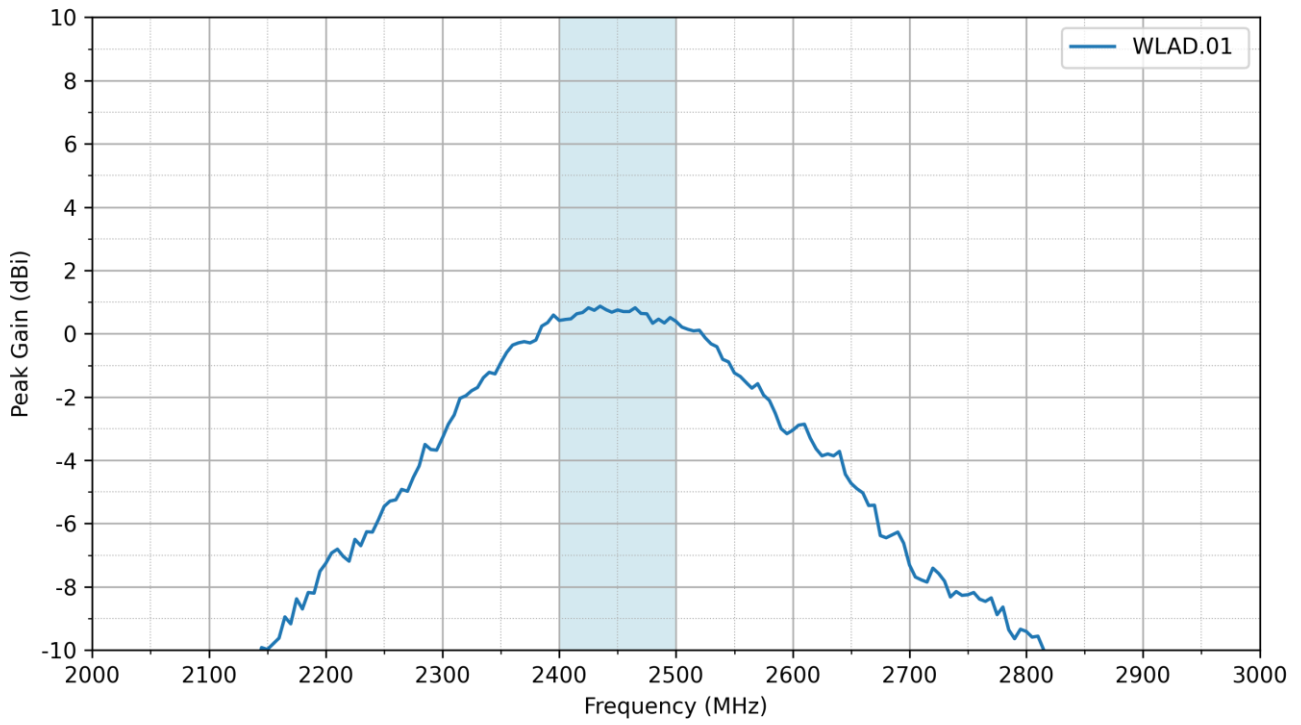

4. Radiation Patterns

4.1 Test Setup

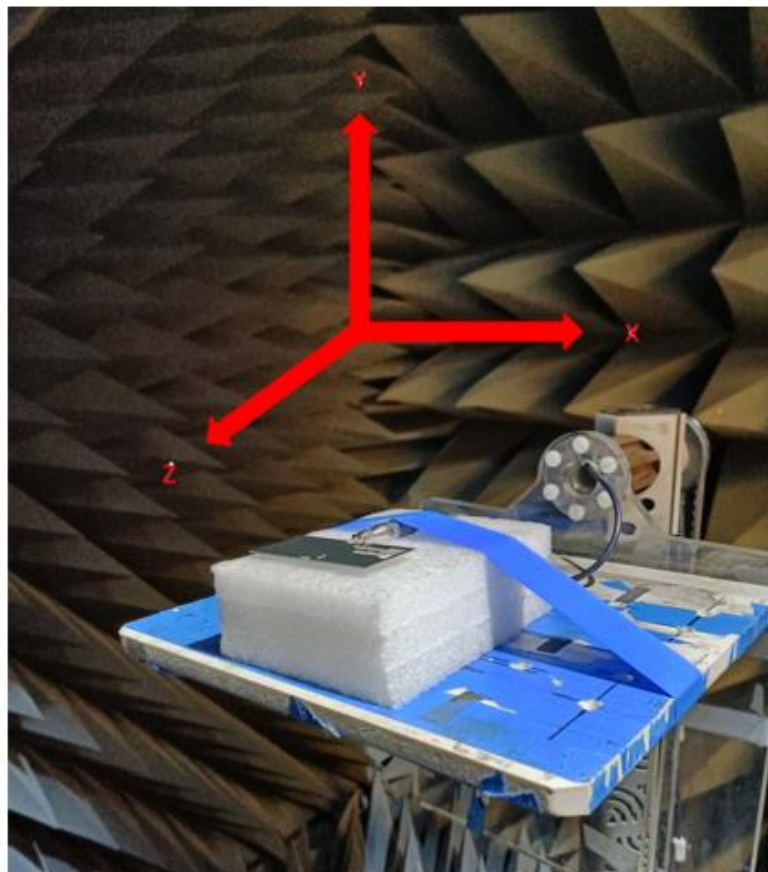
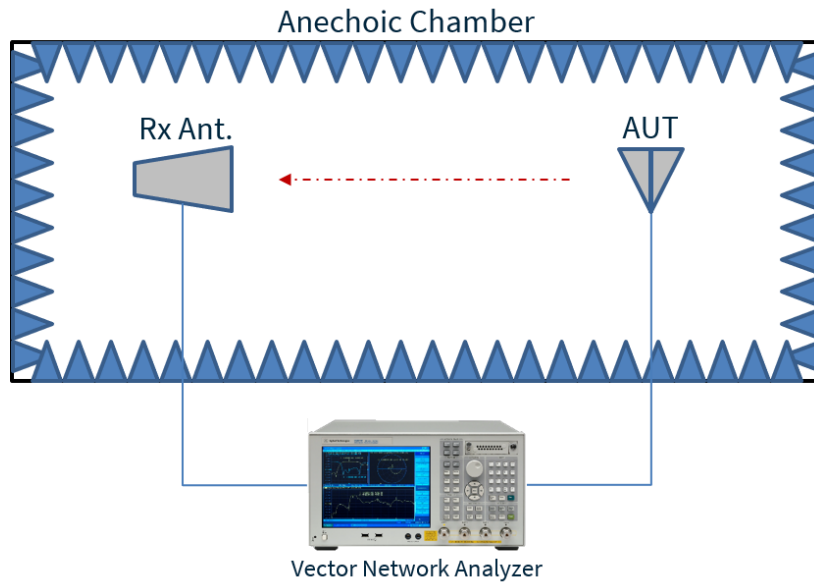

4.2 Patterns at 2400 MHz

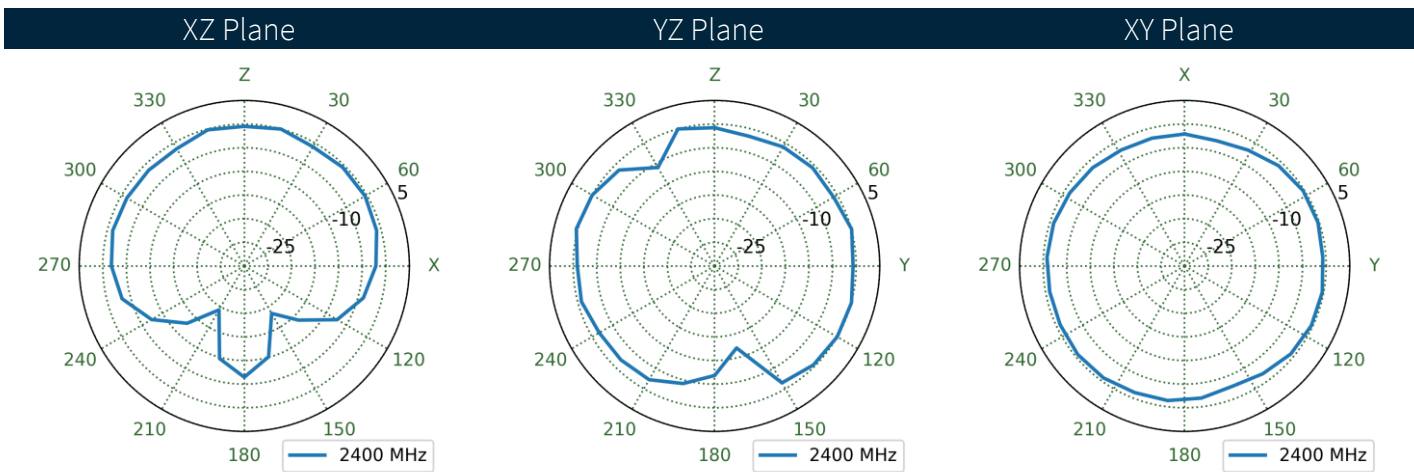
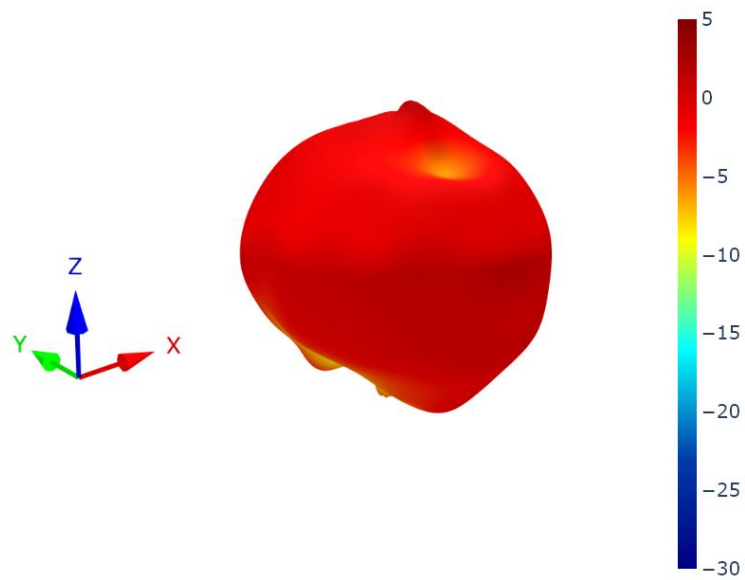

4.3 Patterns at 2450 MHz

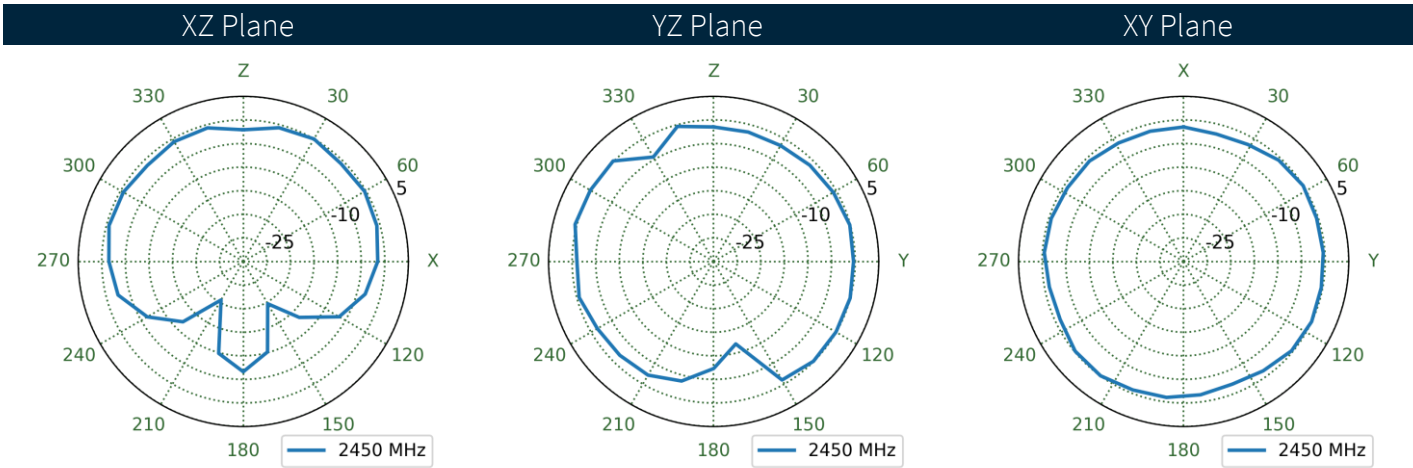
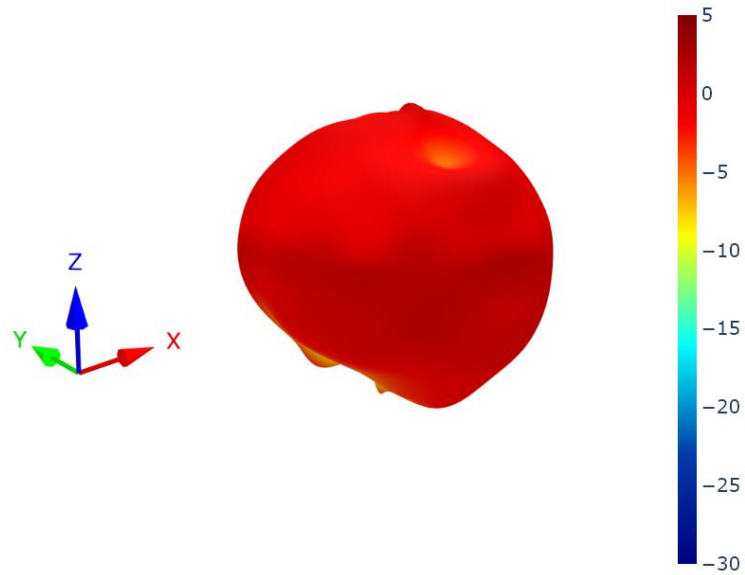

4.4 Patterns at 2500 MHz

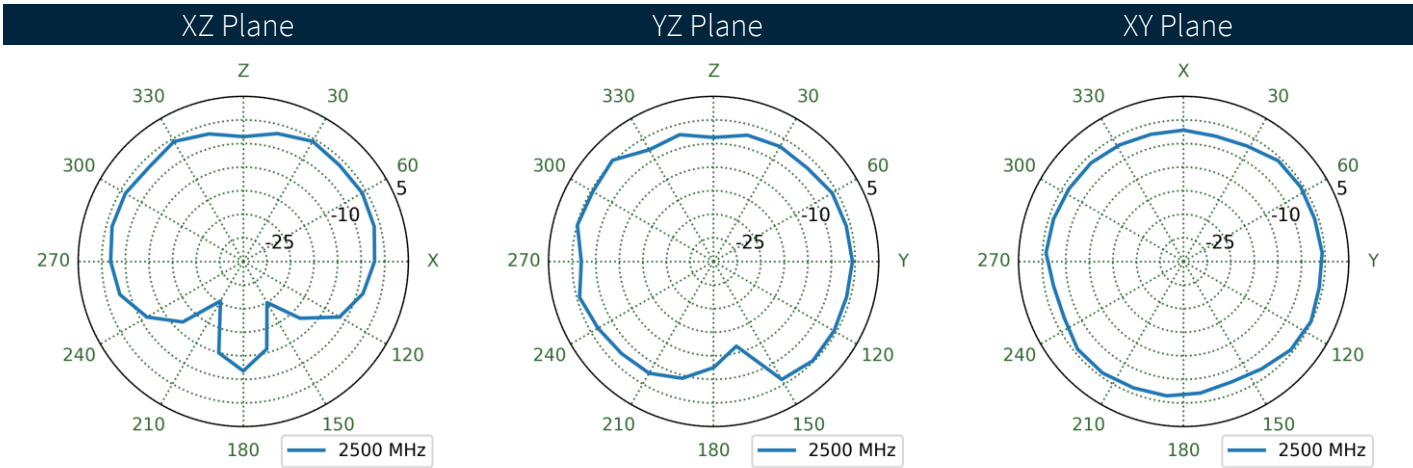
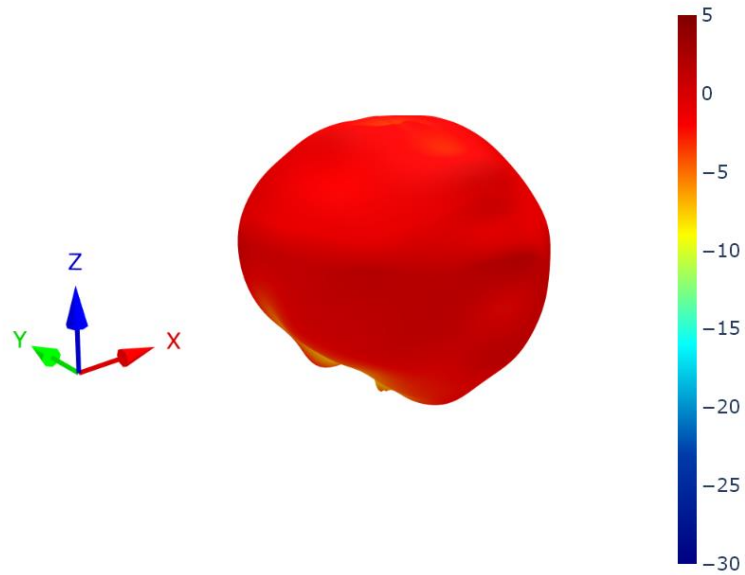

5. Mechanical Drawing

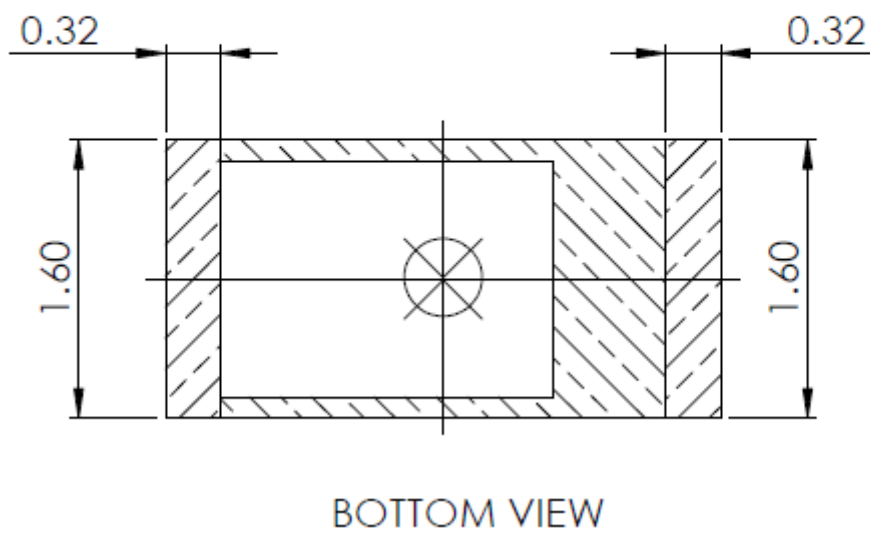
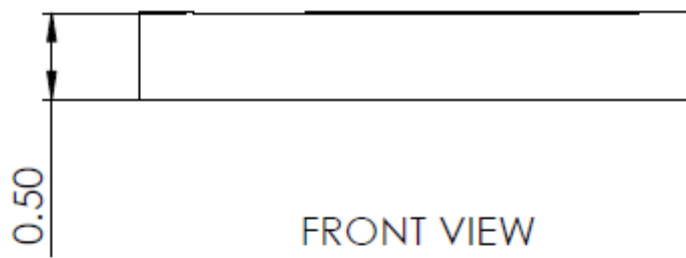
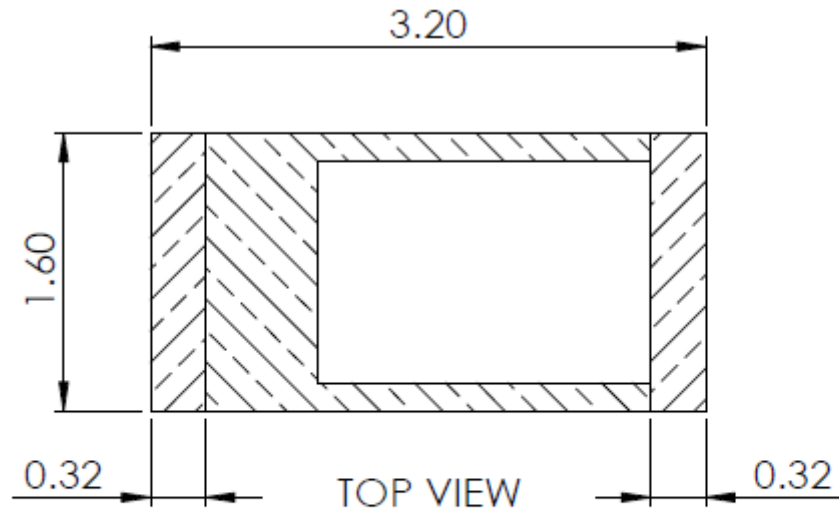

6. Antenna Integration Guide



6.1 Schematic Symbol and Pin Definitions

The circuit symbol for the antenna is shown below. The antenna has 3 pins with all three pins as functional.

Pin	Description
1	RF Feed
2	Ground
3	Fine Tuning Element

TAOGLAS_WLA.01
ANT1

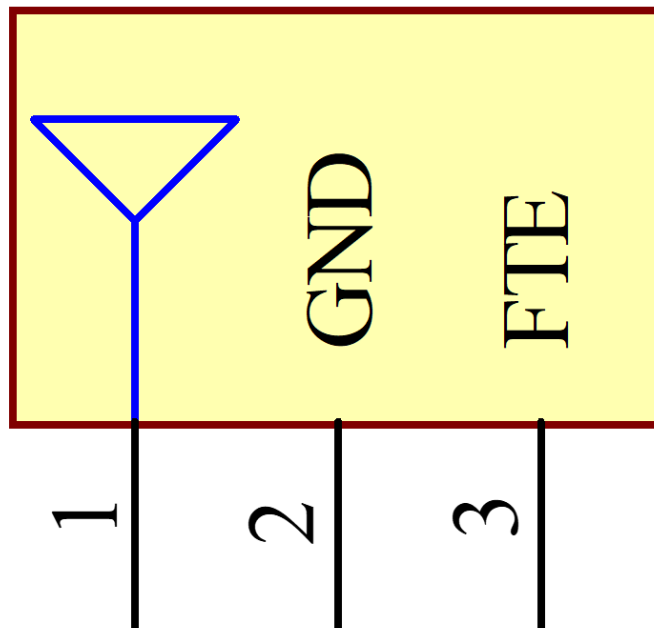

6.2 Antenna Integration

For any given PCB size, the antenna should ideally be placed on the PCB's longest side, to take advantage of the ground plane. Optimized matching components can be placed as shown.



With Solder Mask

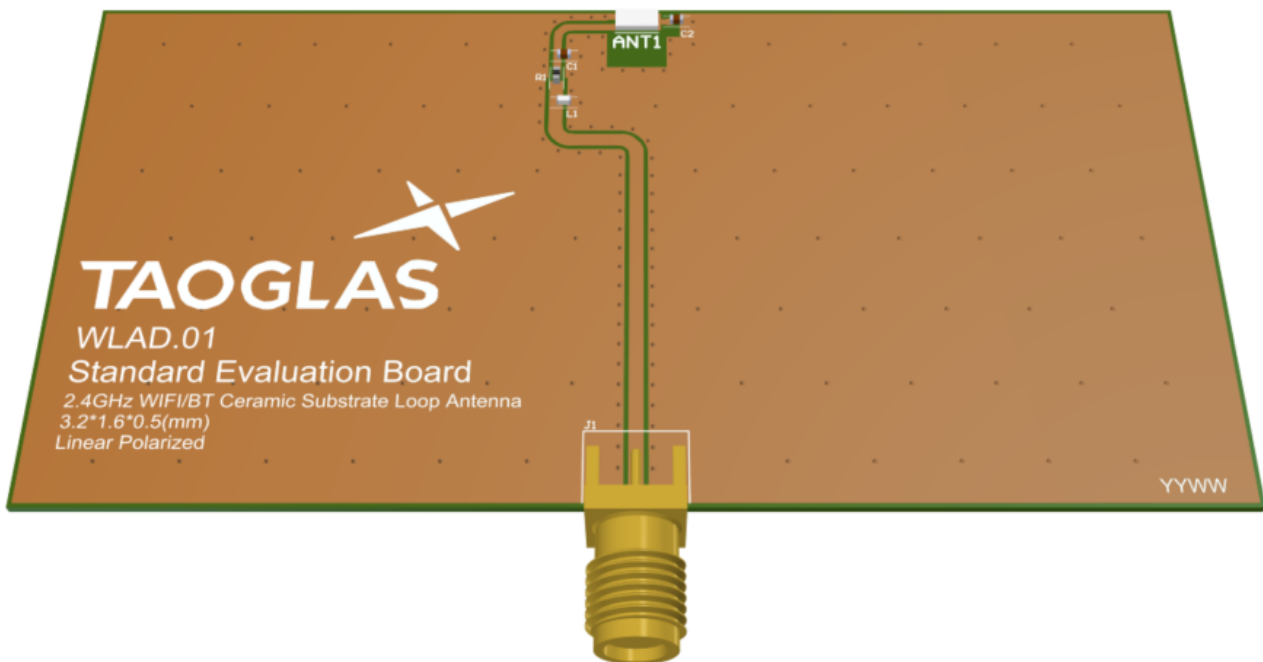

Without Solder Mask

6.3 PCB Layout

The footprint and clearance on the PCB must meet the layout drawing in section 6.7. Note the placement of the optimized components. C1 is placed as close as possible to the RF feed (pad 1) and R1 is then placed tightly in series after that followed by L1 in parallel. C2 is placed close to the Fine-Tuning Element (Pad 3) across the copper keep out are and the ground plane.

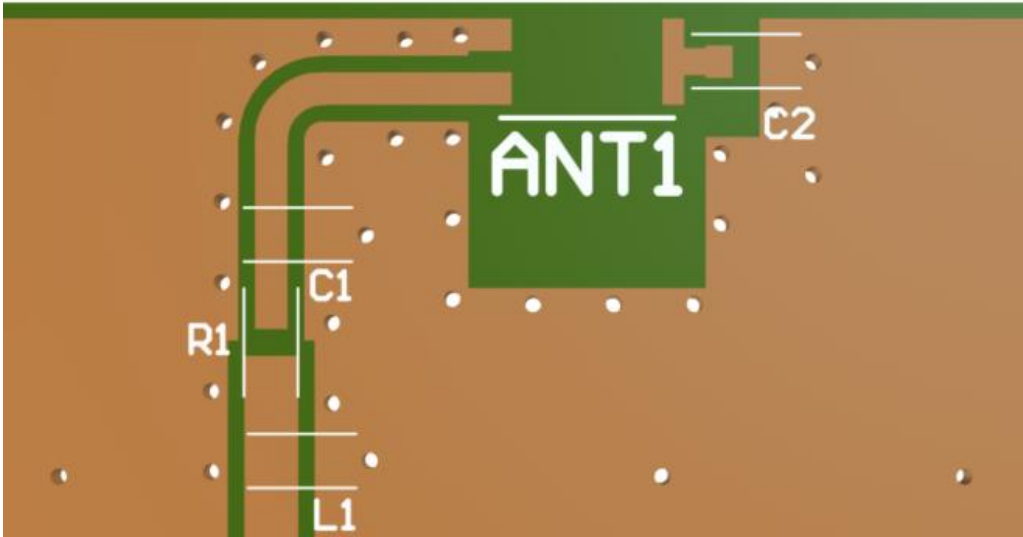

Without Components

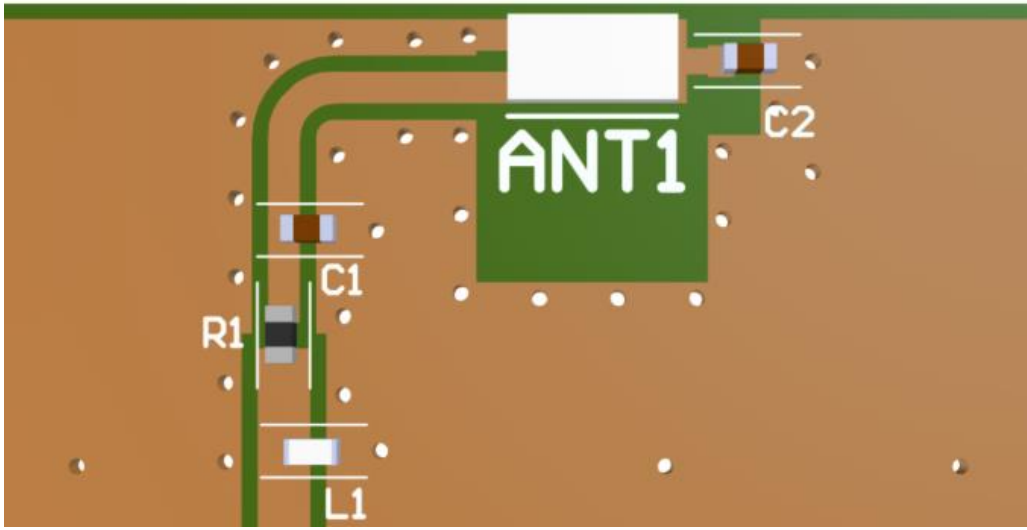

With Components

6.4 PCB Clearance

Below shows the antenna footprint and clearance through ALL layers on the PCB. Only the antenna pads and connections to feed and GND are present within this clearance area (marked RED). The clearance area extends to 5mm in length and 5.4mm in width from the centre of the topside of the PCB. This clearance area includes the bottom side and ALL internal layers on the PCB.

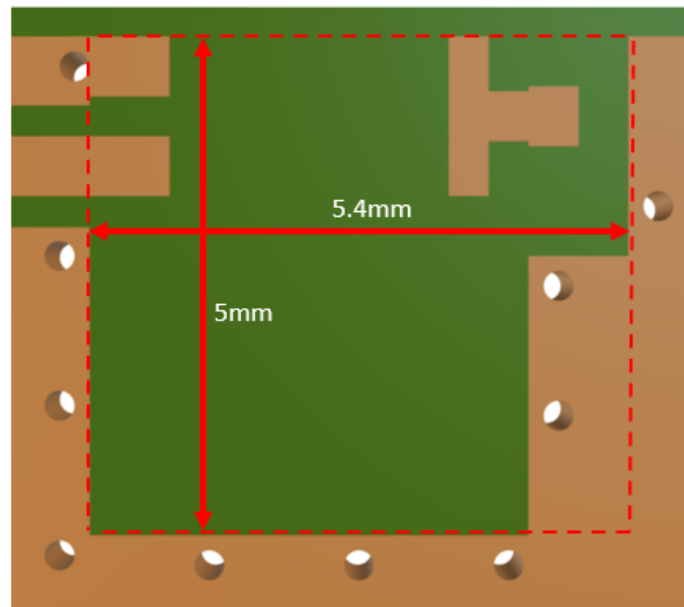

6.5 Evaluation Board

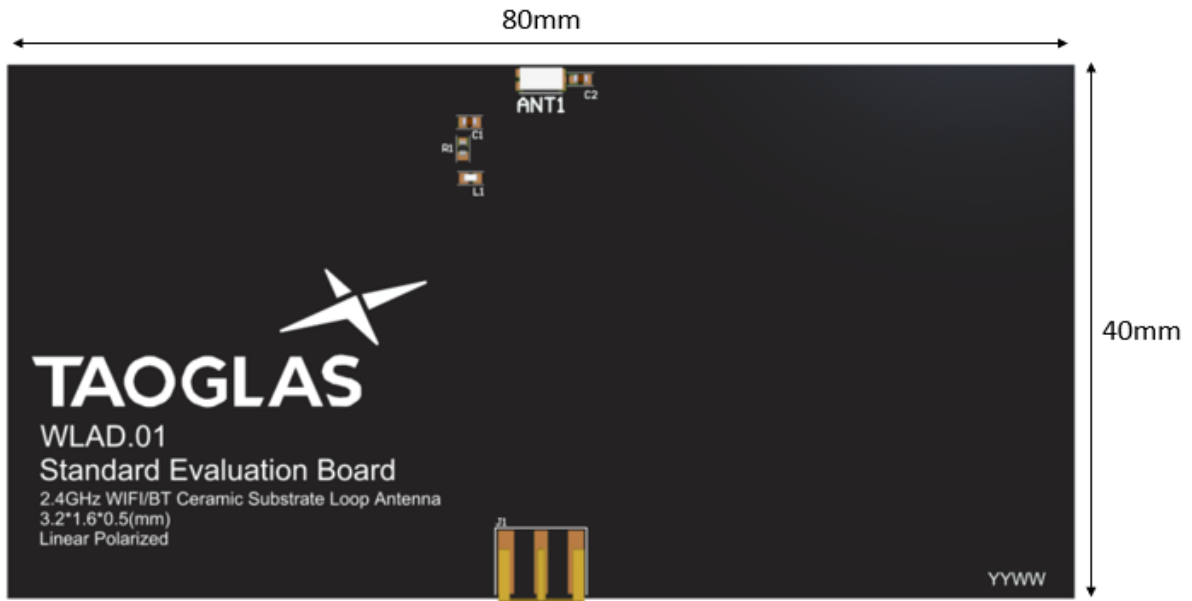

Front View



Back View

6.6 Matching Circuit

Matching components with the WLA.01 are required for the antenna to have optimal performance on the evaluation board, located in the spaces specified in the above images. Additional matching components may be necessary for your device, so we recommend incorporating extra component footprints, forming a “pi” network, between the cellular module and the edge of the ground plane.

Designator	Type	Value	Manufacturer
C1	Capacitor	1.5pF	Murata Electronics
C2	Capacitor	3.9pF	Murata Electronics
L1	Inductor	2.2nH	TDK Corporation
R1	Resistor	0 Ohms	YAGEO

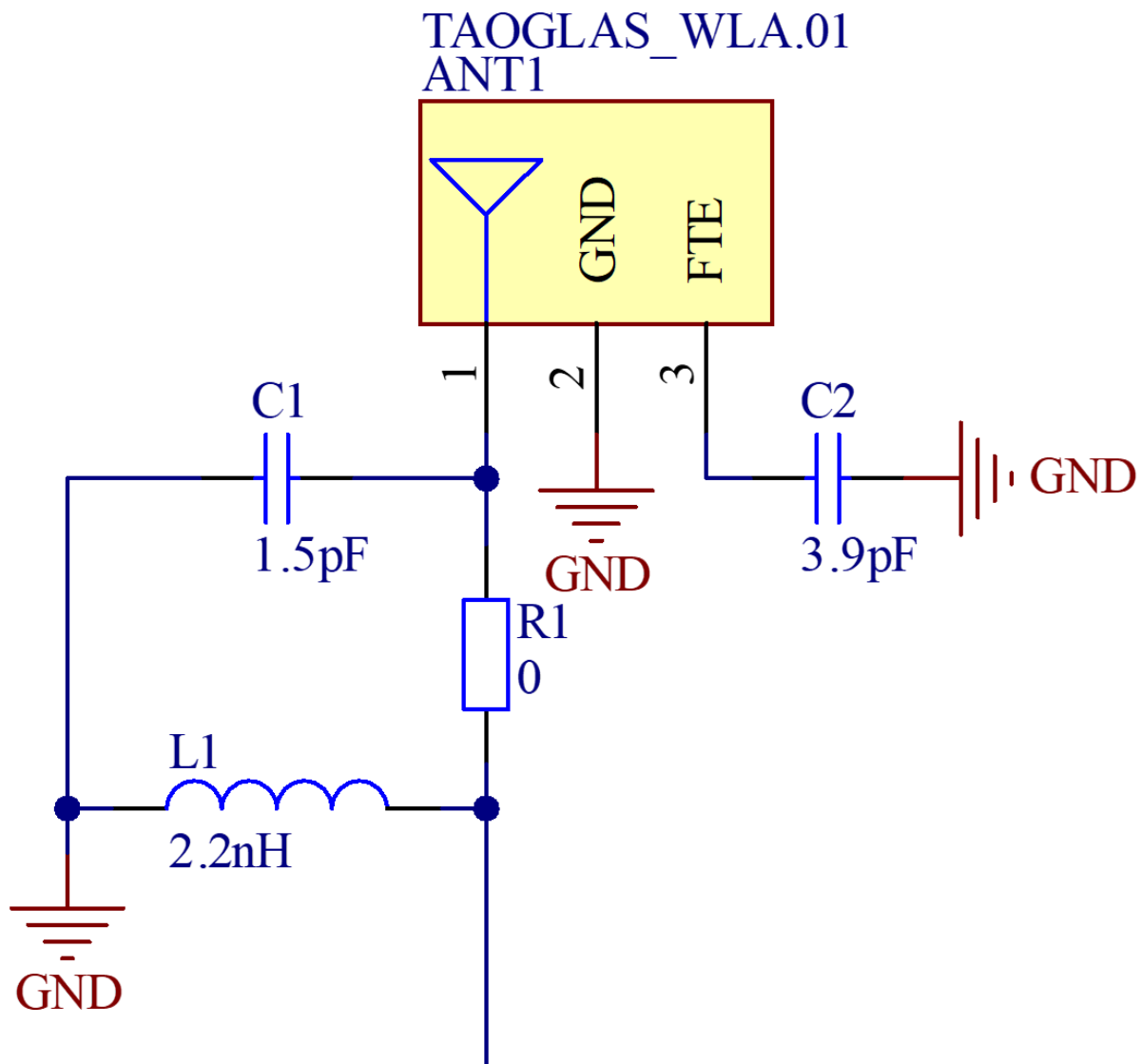

6.7 Footprint

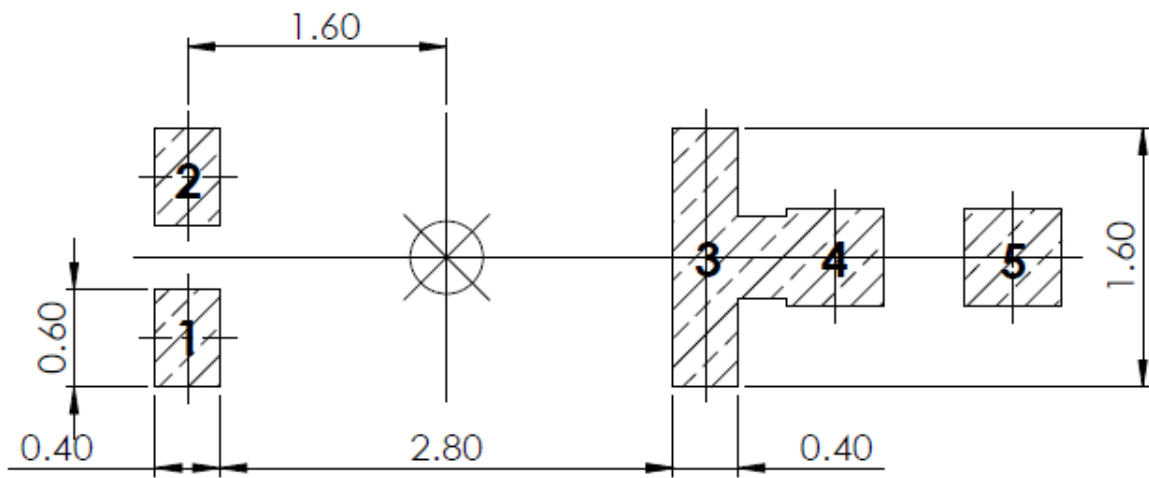

PCB FOOTPRINT

<u>PIN:</u>	<u>DESCRIPTION:</u>
1	Feed (50 ohm)
2	Ground
3	FTE
4,5	Fine Tuning Components

6.8 Copper Keepout Area

- NOTES:
-  - COPPER AREA
 -  - COPPER KEEPOUT AREA
 -  - PASTE AREA

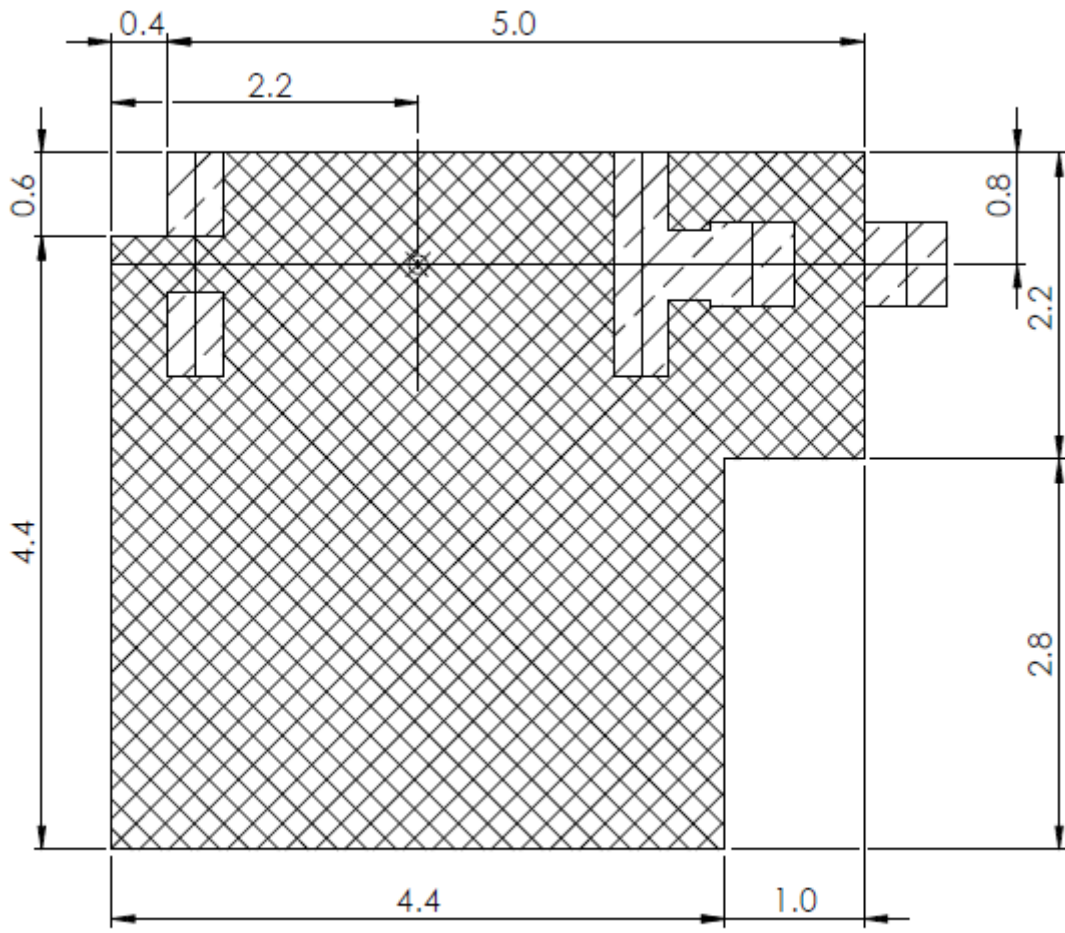

COPPER KEEPOUT AREA

6.9 Top Solder Paste

- NOTES:
-  - COPPER AREA
 -  - COPPER KEEPOUT AREA
 -  - PASTE AREA

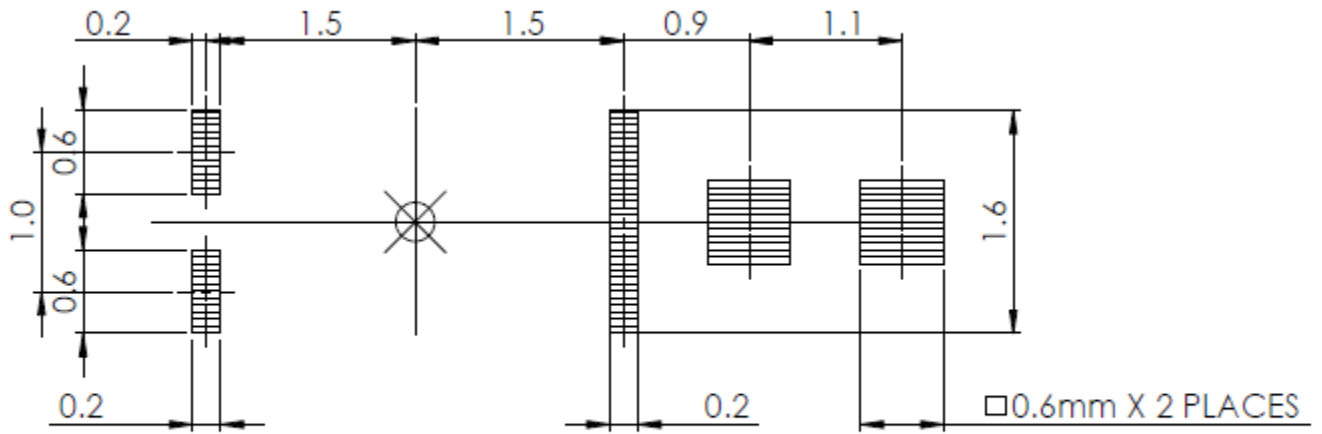

TOP SOLDER PASTE

7. Solder Reflow Profile

The WLA.01 can be assembled by following the recommended soldering temperatures are as follows:

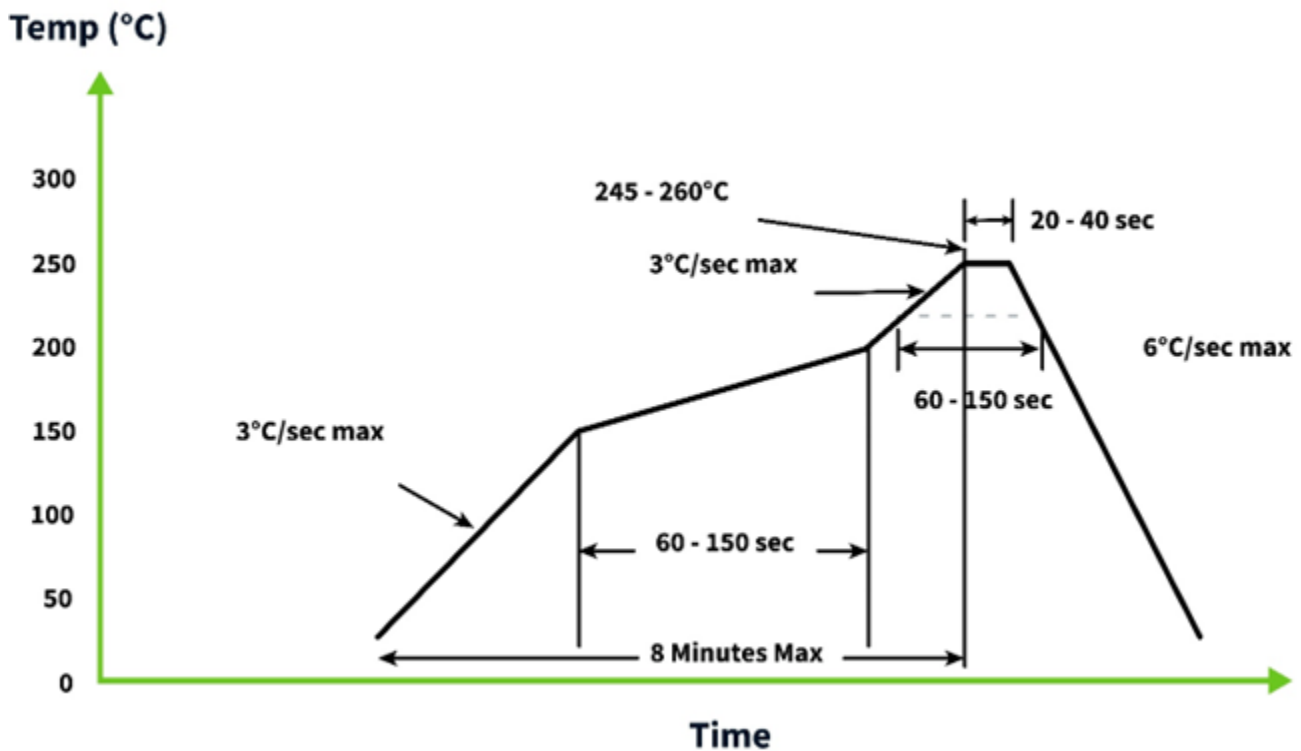

*Temperatures listed within a tolerance of +/- 10° C

Smaller components are typically mounted on the first pass, however, we do advise mounting the WLA.01 when placing larger components on the board during subsequent reflows.

8. Packaging

5000pcs WLA.01 per Tape and Reel
 Dimensions: $\varnothing 330 \times 60$ mm
 Weight: 3.23Kg

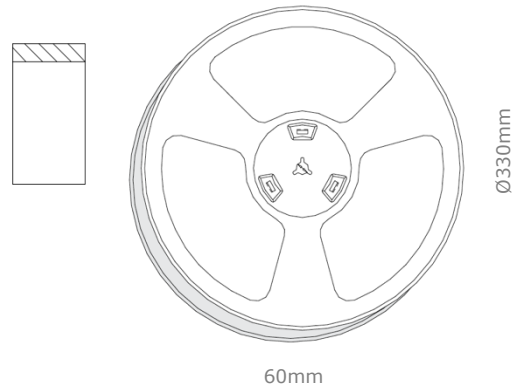

5000pcs WLA.01 per Carton
 Dimensions: 340*340*90mm
 Weight: 3.5Kg

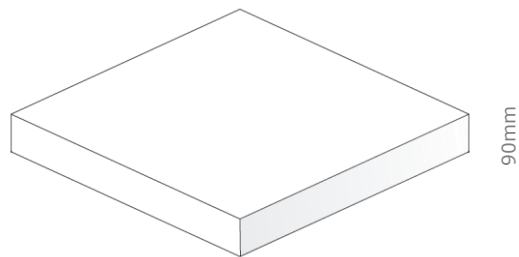

9. Application Note

This application note is to show the WLA.01 performance when mounted on the corner of a 60x30mm PCB.

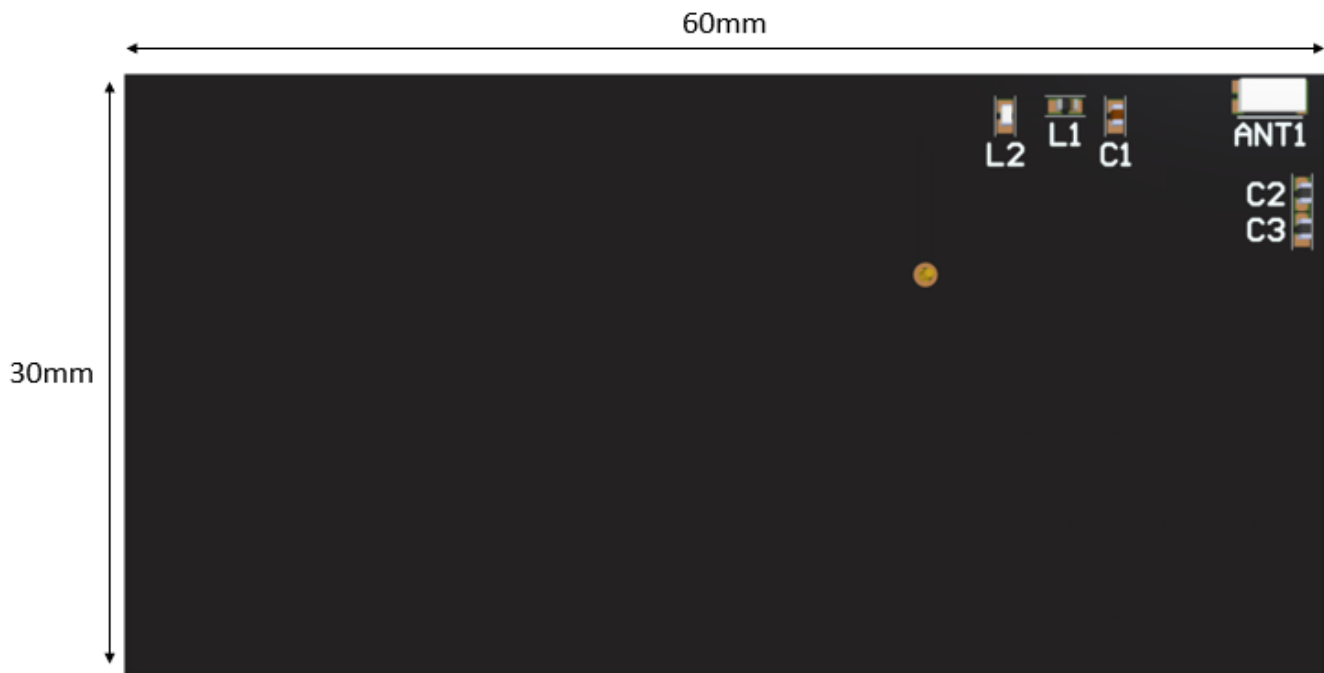

9.1 Return Loss

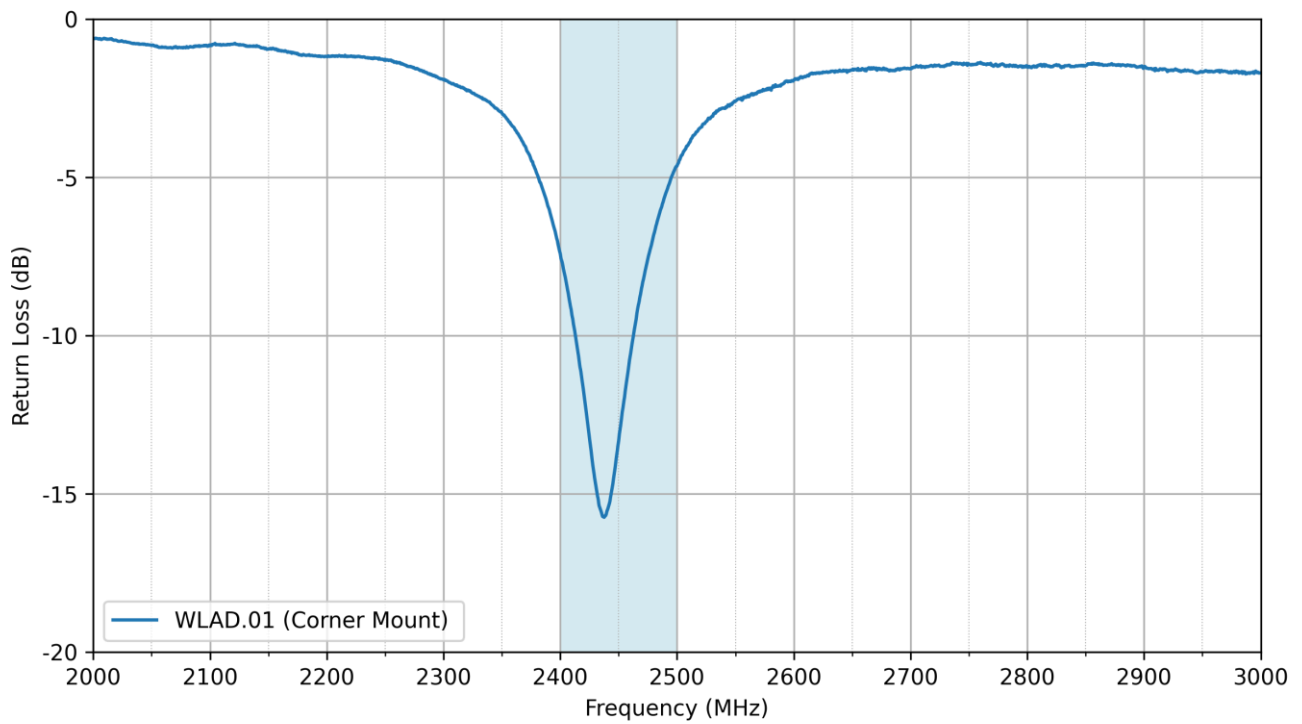

9.2 Efficiency

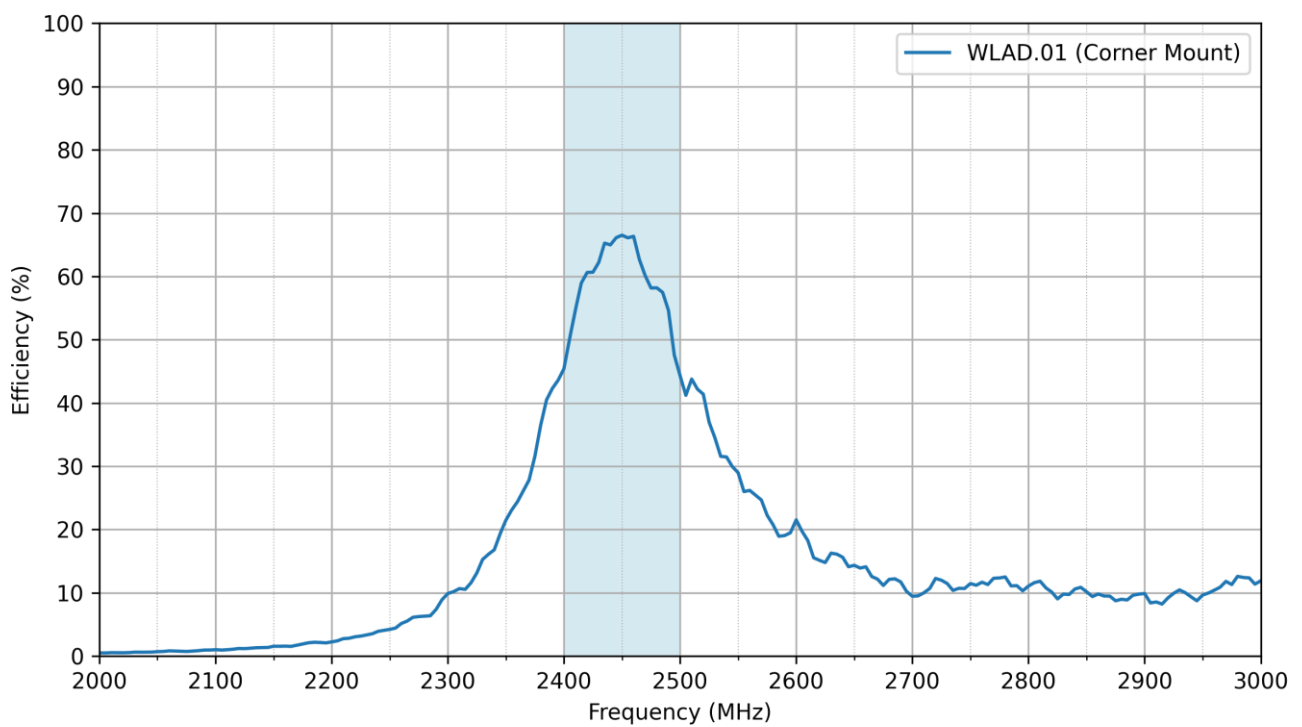

9.3 Average Gain

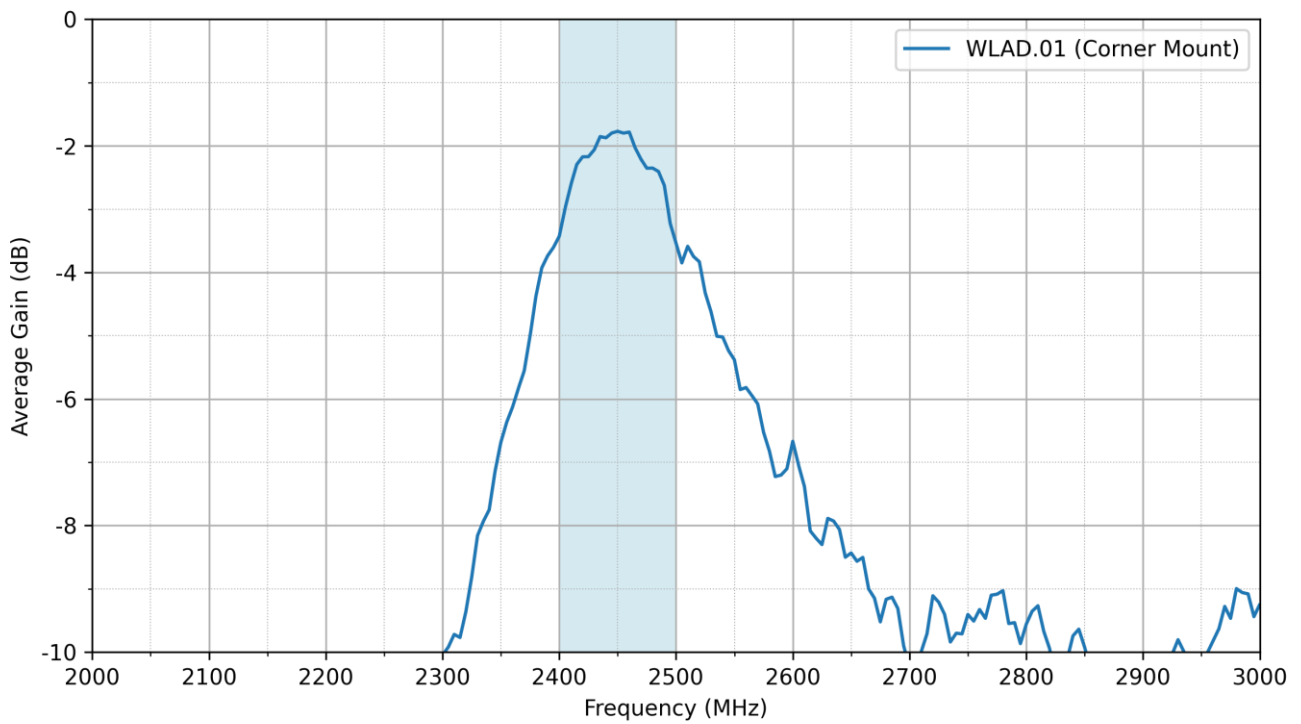

9.4 Peak Gain

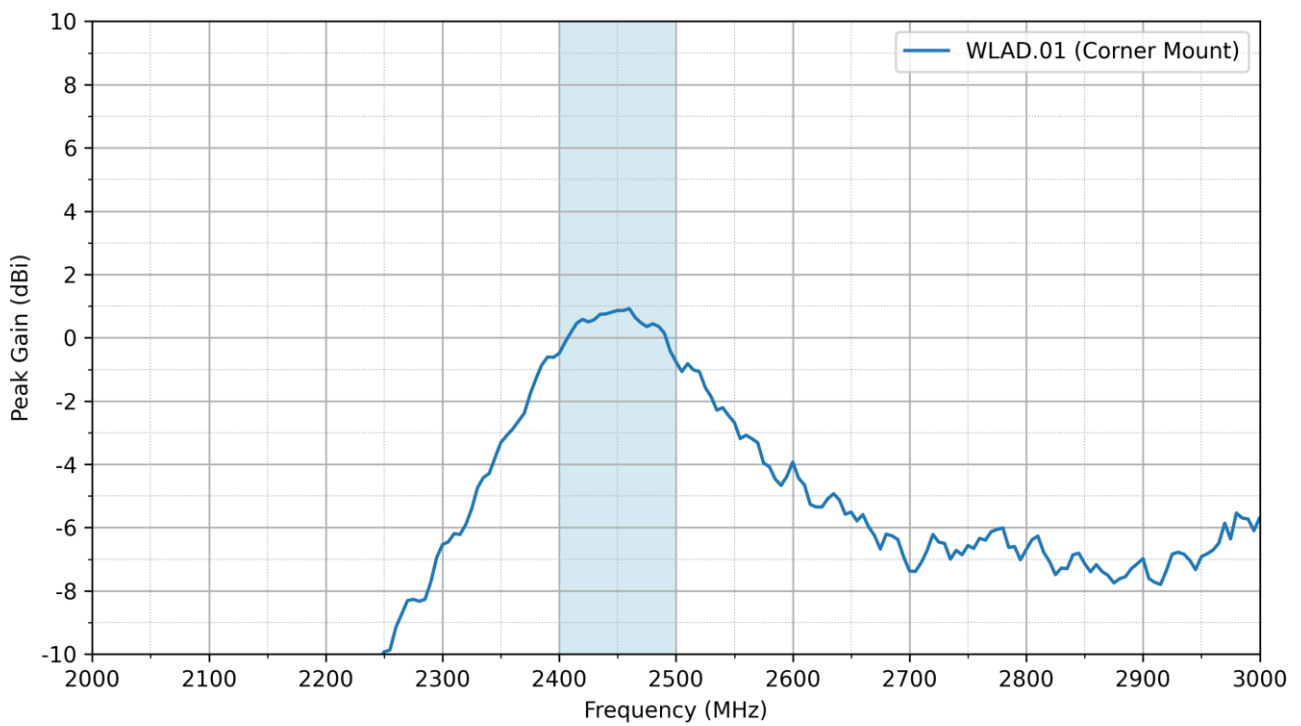

9.5 Schematic Symbol and Pin Definitions

The circuit symbol for the antenna is shown below. The antenna has 3 pins with all three pins as functional.

Pin	Description
1	RF Feed
2	Ground
3	Fine Tuning Element

TAOGLAS_WLA.01
ANT1

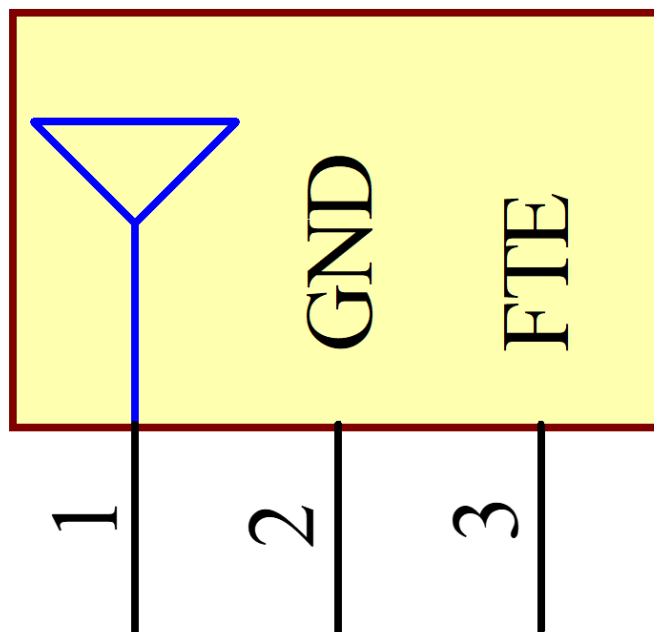

9.6 Antenna Integration

For any given PCB size, the antenna should ideally be placed on the PCB's longest side, to take advantage of the ground plane. Optimized matching components can be placed as shown.

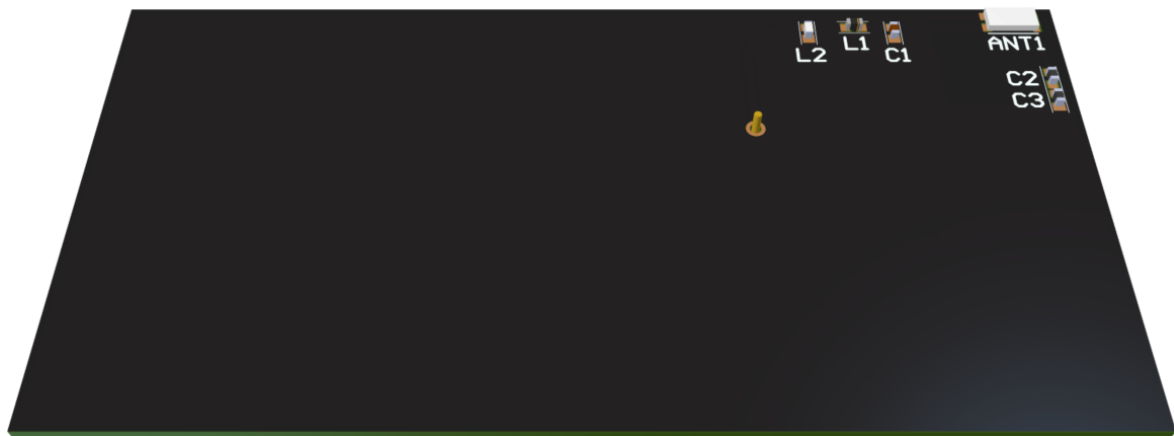

With Solder Mask

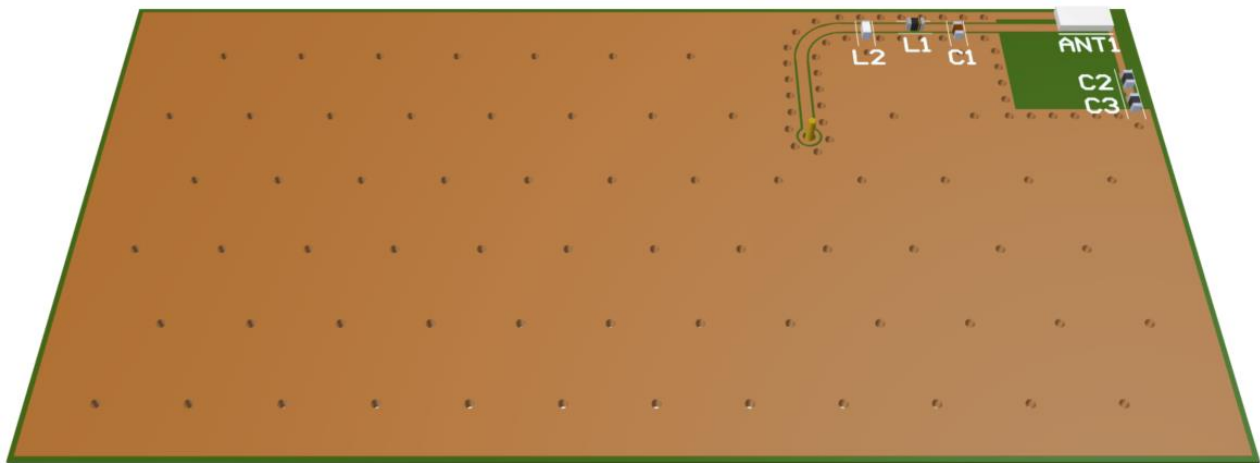

Without Solder Mask

9.7 PCB Layout

The footprint and clearance on the PCB must meet the layout drawing in section 9.11. Note the placement of the optimized components. C1 is placed as close as possible to the RF feed (pad 1) and L1 is then placed tightly in series after that followed by L2 in parallel. C2 and C3 are connected to the Fine-Tuning Element (Pad 3) as shown below. C3 is placed across the copper keep out area.

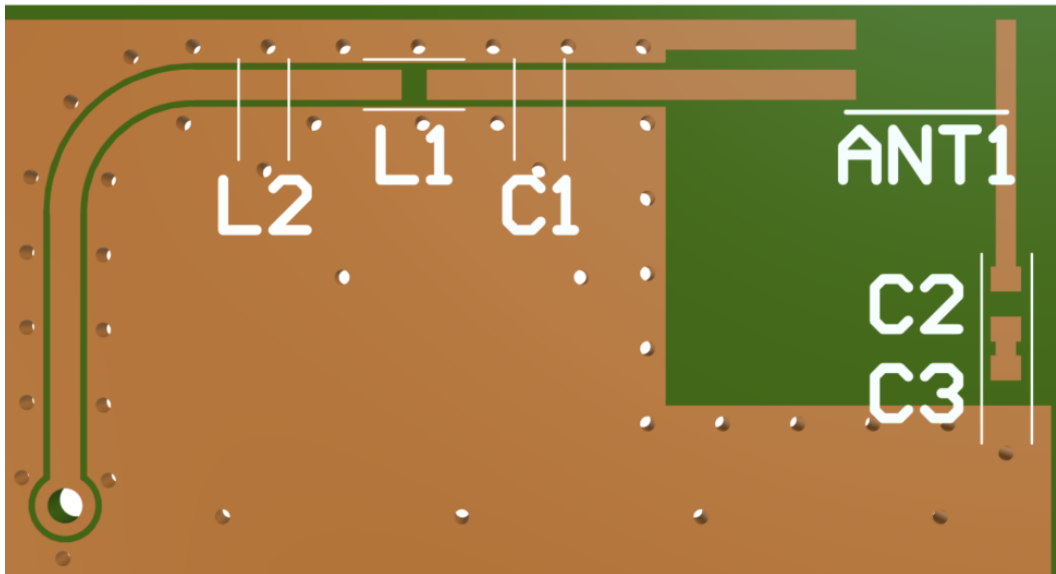

Without Components

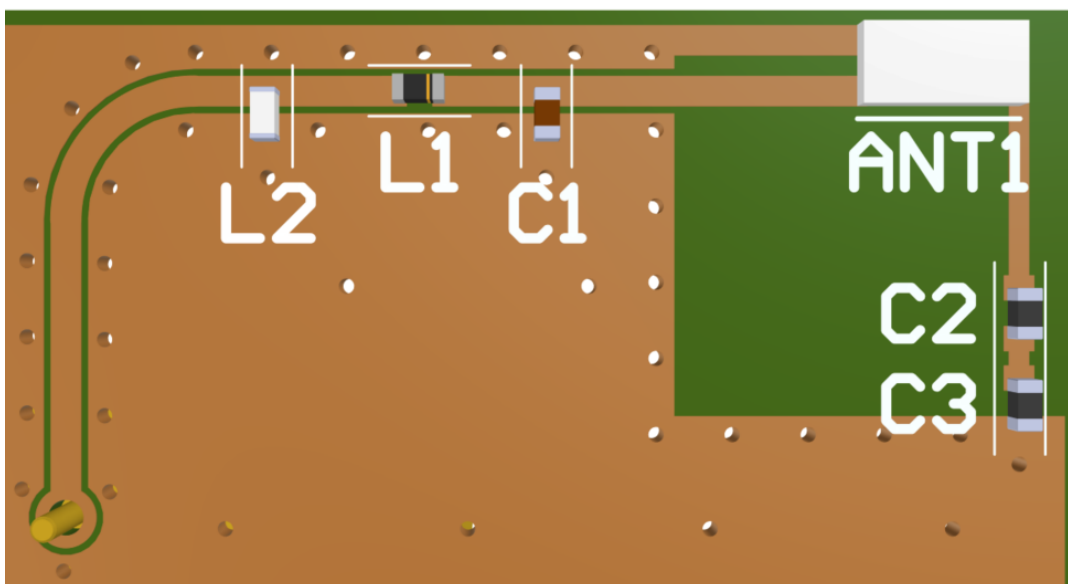

With Components

9.8 PCB Clearance

Below shows the antenna footprint and clearance through ALL layers on the PCB. Only the antenna pads and connections to feed and GND are present within this clearance area (marked RED). The clearance area extends to 8mm in width and 8mm in length from the corner of the PCB. This clearance area includes the bottom side and ALL internal layers on the PCB.

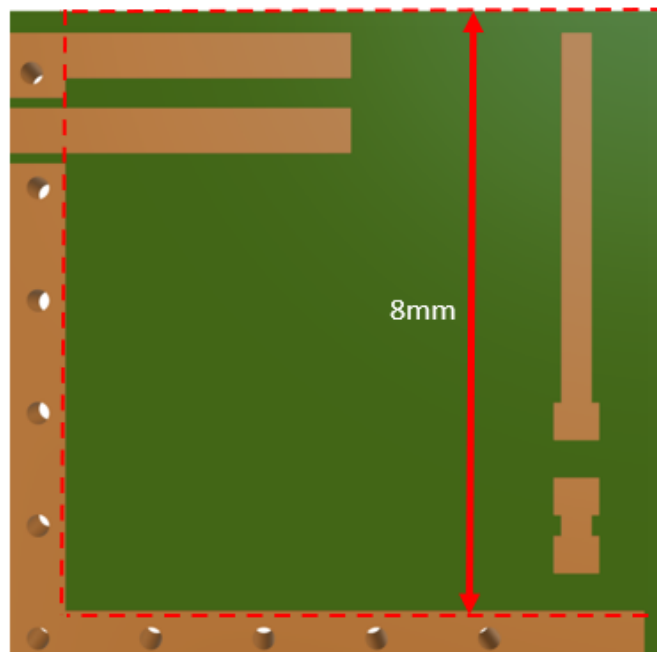

Top Side

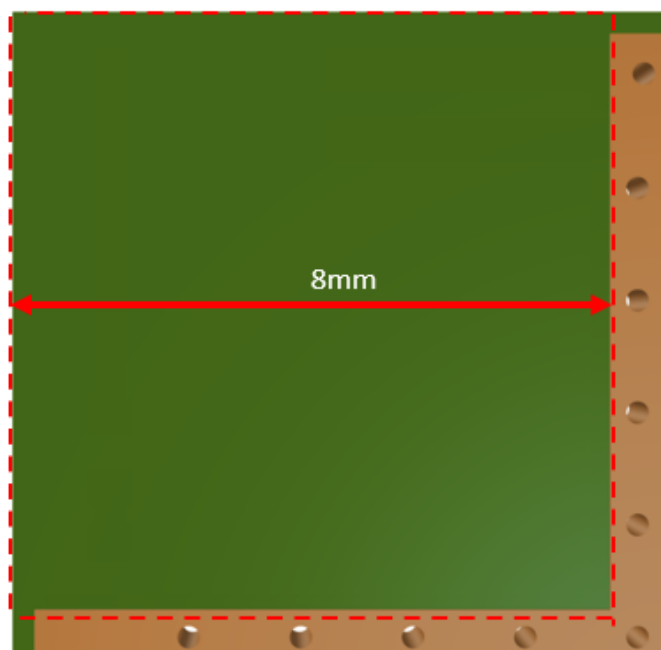

Bottom Side

9.9 Evaluation Board

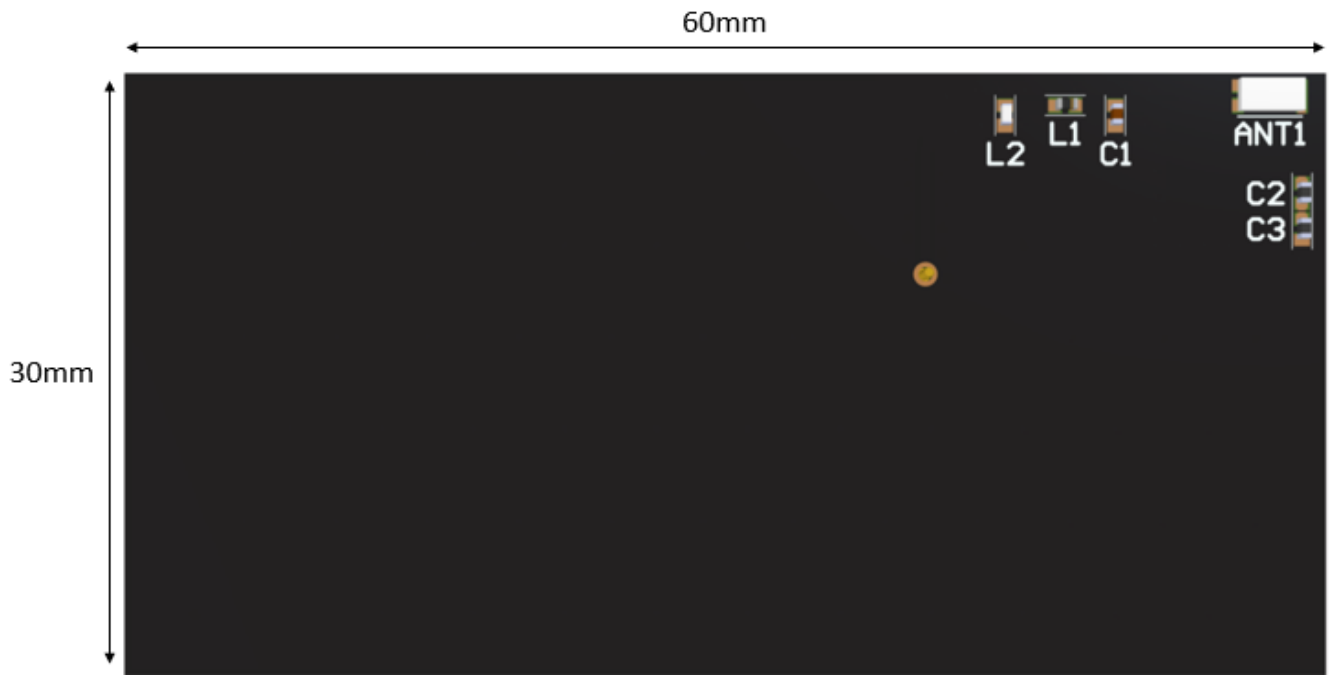

Front View

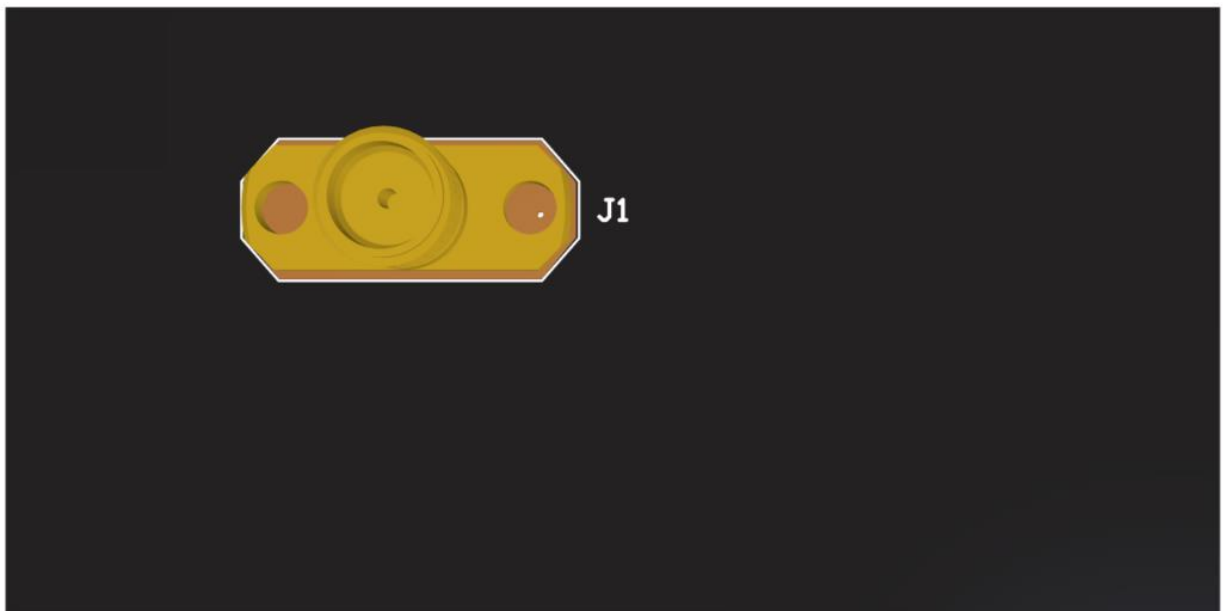

Back View

9.10 Matching Circuit

Matching components with the WLA.01.B are required for the antenna to have optimal performance on the evaluation board, located outside of the ground plane in the space specified in the above images. Additional matching components may be necessary for your device, so we recommend incorporating extra component footprints, forming a “pi” network, between the cellular module and the edge of the ground plane.

Designator	Type	Value	Manufacturer
C1	Capacitor	0.5pF	Murata
C2, C3	Capacitor	0.7pF	Yageo
L1	Inductor	3nH	TDK
L2	Inductor	1.8nH	TDK

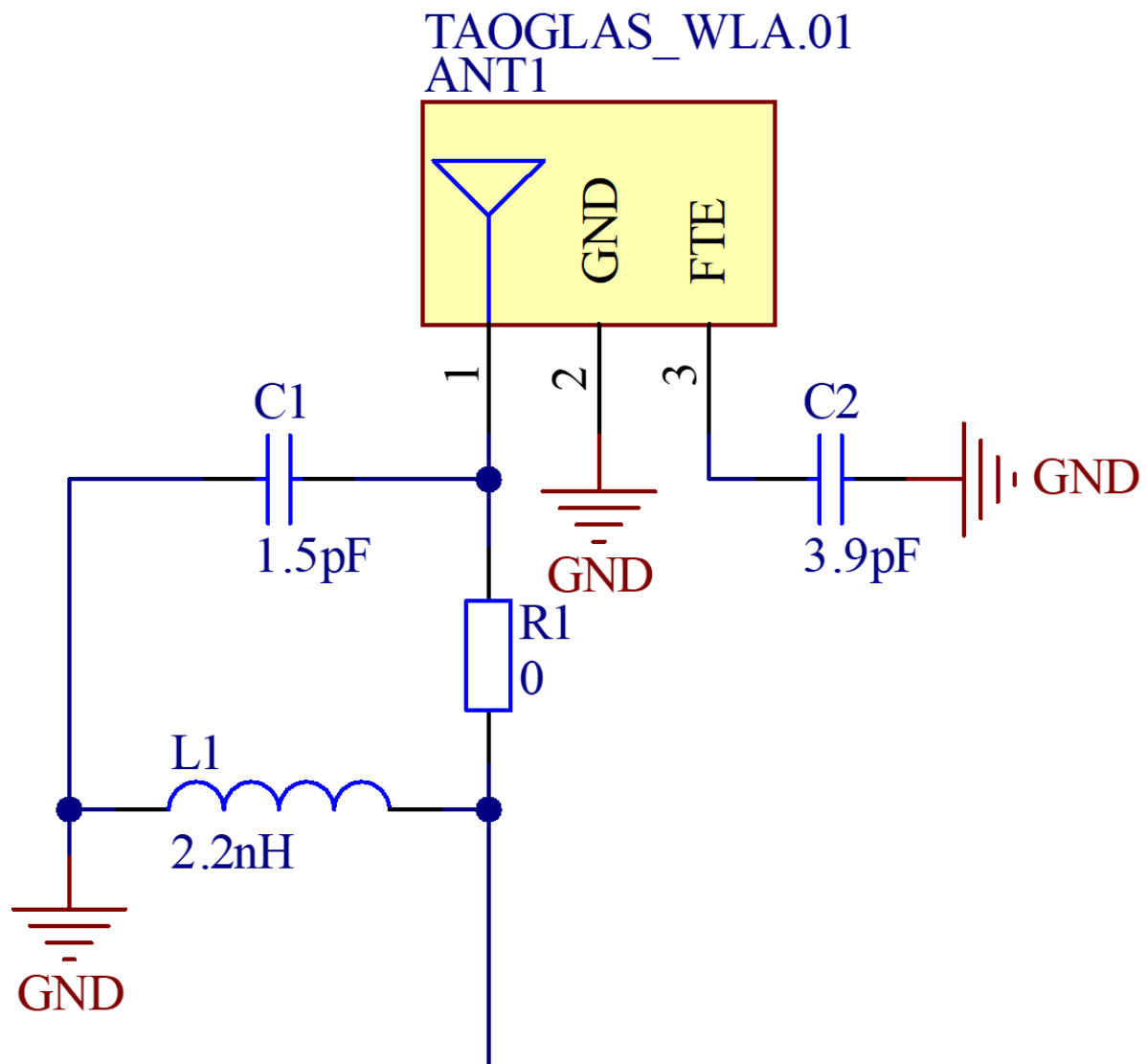

9.11 Footprint

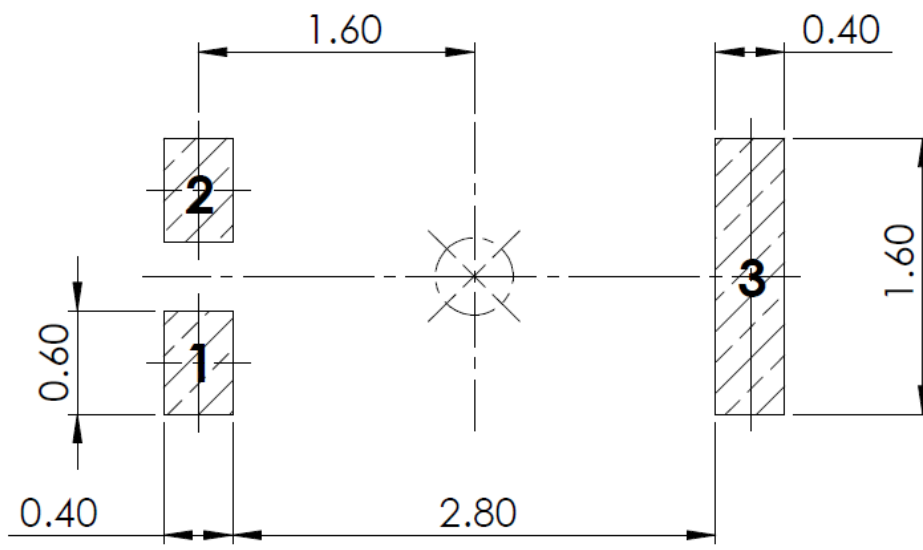

PCB FOOTPRINT

Changelog for the datasheet

SPE-11-8-146 – WLA.01

Revision: U (Current Version)

Date:	2024-02-01
Changes:	Updated packaging information
Changes Made by:	Cesar Sousa

Previous Revisions

Revision: T

Date:	2023-11-09
Changes:	Full datasheet update.
Changes Made by:	Gary West

Revision: O

Date:	2022-01-14
Changes:	Updated Antenna Integration Guide
Changes Made by:	Gary West

Revision: S

Date:	2023-09-06
Changes:	Updated Solder Reflow Information
Changes Made by:	Cesar Sousa

Revision: N

Date:	2021-10-18
Changes:	Full datasheet template update, Retested antenna and populated graphs, Added MSL to spec table & Added antenna integration guide.
Changes Made by:	Gary West

Revision: R

Date:	2023-02-20
Changes:	Updated Electrical Specifications
Changes Made by:	Cesar Sousa

Revision: M

Date:	2019-08-27
Changes:	Updated drawings, packaging and overall typography
Changes Made by:	Russell Meyler

Revision: Q

Date:	2023-01-02
Changes:	Updated Specifications
Changes Made by:	Cesar Sousa

Revision: L

Date:	2018-09-10
Changes:	
Changes Made by:	Jack Conroy

Revision: P

Date:	2022-07-05
Changes:	Updated Footprint ME drawing.
Changes Made by:	Gary West

Revision: K

Date:	2016-12-20
Changes:	Updated drawing as per PCN-80
Changes Made by:	Andy Mahoney

Previous Revisions (Continued)

Revision: J	
Date:	2016-09-28
Changes:	Amended drawing to make clearer that only certain pads should be connected to GND
Changes Made by:	Jack Conroy

Revision: D	
Date:	2014-01-31
Changes:	Amended drawings of EVB
Changes Made by:	Aine Doyle

Revision: I	
Date:	2016-09-13
Changes:	
Changes Made by:	Technical Writer

Revision: C	
Date:	2012-06-27
Changes:	
Changes Made by:	Technical Writer

Revision: H	
Date:	2015-08-21
Changes:	Added note on gain
Changes Made by:	Aine Doyle

Revision: B	
Date:	2012-12-01
Changes:	
Changes Made by:	Technical Writer

Revision: G	
Date:	2014-07-23
Changes:	Updated Frequency Page 3
Changes Made by:	Aine Doyle

Revision: A (Original First Release)	
Date:	2011-11-30
Notes:	First Release
Author:	Technical Writer

Revision: F	
Date:	2014-07-14
Changes:	Added in Solder details
Changes Made by:	Aine Doyle

Revision: E	
Date:	2014-04-23
Changes:	Amended 6.2 Mtaching component table
Changes Made by:	Aine Doyle

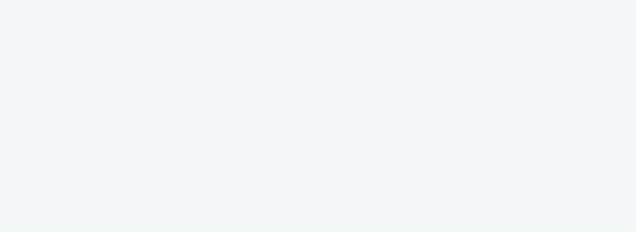
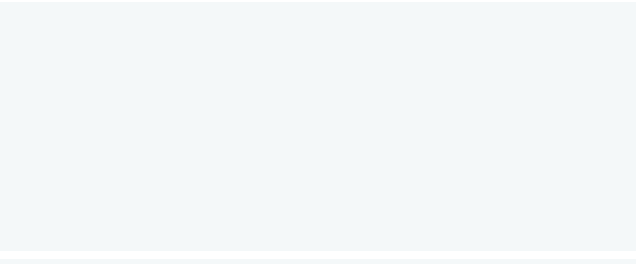



www.taoglas.com

