

N-Channel Logic Level Enhancement-Mode Power Field-Effect Transistors

May 1992

Features

- 2A, 60V
- $r_{DS(on)} = 0.160\Omega$
- UIS Rating Curve (Single Pulse)
- Design Optimized For 5 Volt Gate Drive
- Can be Driven Directly from CMOS, NMOS, TTL Circuits
- Compatible with Automotive Drive Requirements
- SOA Is Power-Dissipation Limited
- Nanosecond Switching Speeds
- Linear Transfer Characteristics
- High Input Impedance
- Majority Carrier Device
- Electrostatic Discharge Protected

Description

The RFW2N06RLE (TA9861) N-Channel logic level ESD protected power MOSFET is manufactured using the MegaFET process. This process, which uses feature sizes approaching those of LSI integrated circuits gives optimum utilization of silicon, resulting in outstanding performance. The RFW2N06RLE was designed for use with logic level (5V) driving sources in applications such as programmable controllers, automotive switching, switching regulators, switching converters, motor and relay drivers and emitter switches for bipolar transistors. This performance is accomplished through a special gate oxide design which provides full rated conduction at gate biases in the 3-5 volt range, thereby facilitating true on-off power control directly from logic circuit supply voltages.

The RFW2N06RLE is supplied in the 4-pin hexdip plastic package. (Similar to JEDEC outline TO-250)

Package

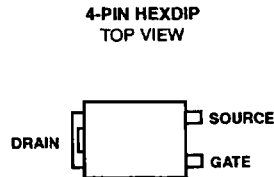

Terminal Diagram

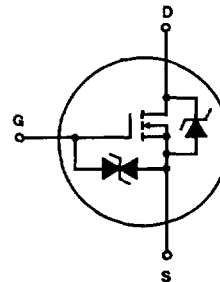

Absolute Maximum Ratings ($T_C = +25^\circ\text{C}$)

| | | UNITS |
|--|----------------|--------------------|
| Drain Source Voltage | V_{DSS} | 60 V |
| Drain Gate Voltage | V_{DGR} | 60 V |
| Gate Source Voltage | V_{GS} | +10, -5 V |
| Drain Current | | |
| RMS Continuous | I_D | 2 A |
| Pulsed Drain Current | I_{DM} | 14 A |
| Single Pulse Avalanche Rating | E_{AS} | Refer to UIS Curve |
| Electrostatic Discharge Rating, MIL-STD-883, Category B(2) | ESD | 2 KV |
| Power Dissipation | | |
| $T_C = +25^\circ\text{C}$ | P_D | 1.09 W |
| Derate Above $+25^\circ\text{C}$ | P_T | 0.009 W/°C |
| Operating and Storage Temperature | T_{STG}, T_J | -55 to +150 °C |

Specifications RFW2N06RLE

Electrical Characteristics Case Temperature (T_C) = +25°C, Unless Otherwise Specified

| CHARACTERISTIC | SYMBOL | TEST CONDITIONS | LIMITS | | | UNITS | |
|--|-----------------|---|----------------------|--|-----|--------------|---------|
| | | | MIN | TYP | MAX | | |
| Drain-Source Breakdown Voltage | BV_{DSS} | $I_D = 0.25mA, V_{GS} = 0V$ | 60 | - | - | V | |
| Gate Threshold Voltage | $V_{GS(th)}$ | $V_{GS} = V_{DS}, I_D = 0.25mA$ | 1 | - | 2 | V | |
| Zero Gate Voltage Drain Current | I_{DSS} | $V_{DS} = 60V, V_{GS} = 0V$ | $T_C = +25^\circ C$ | - | -1 | 1 | μA |
| | | | $T_C = +150^\circ C$ | - | - | 50 | μA |
| Gate-Source Leakage Current | I_{GSS} | $V_{GS} = +10V, V_{DS} = -5V$ | - | - | 10 | μA | |
| | | | - | - | 10 | μA | |
| On Resistance | $r_{DS(on)}$ | $I_D = 2A, V_{GS} = 5.0V, I_D = 2A, V_{GS} = 4.3V$ | - | - | 160 | m Ω | |
| | | | - | - | 200 | m Ω | |
| Turn-On Time | t_{on} | $V_{DD} = 30V, I_D = 2A, R_L = 15\Omega, V_{GS} = 5V, R_{GS} = 25\Omega$ | - | - | 100 | ns | |
| Turn-On Delay Time | $t_{d(on)}$ | | - | 13 | - | ns | |
| Rise Time | t_r | | - | 42 | - | ns | |
| Turn-Off Delay Time | $t_{d(off)}$ | | - | 95 | - | ns | |
| Fall Time | t_f | | - | 45 | - | ns | |
| Turn-Off Time | t_{off} | | - | - | 200 | ns | |
| Total Gate Charge | $Q_{g(to)}$ | | $V_{GS} = 0$ to 10V | $V_{DD} = 48V, I_D = 2A, R_L = 24\Omega$ | - | 20 | 30 |
| Gate Charge at 5V | $Q_g(5)$ | $V_{GS} = 0$ to 5V | - | | 11 | 16 | nC |
| Threshold Gate Charge | $Q_g(th)$ | $V_{GS} = 0$ to 1V | - | | 0.6 | 1.0 | nC |
| Plateau Voltage | $V_{(plateau)}$ | $I_D = 2A, V_{DS} = 15V$ | - | - | 4.3 | V | |
| Input Capacitance | C_{iss} | $V_{DS} = 25V, V_{GS} = 0V, f = 1MHz$ | - | 535 | - | pF | |
| Output Capacitance | C_{oss} | | - | 175 | - | pF | |
| Reverse Transfer Capacitance | C_{rss} | | - | 32 | - | pF | |
| Turn-Off Energy Loss per Cycle | E_{off} | $V_{DD} = 30V, I_D = 2A, L = 0.21\mu H, R_L = 15\Omega, V_{GS} = 5V, R_{GS} = 25\Omega$ | - | - | 10 | μJ | |
| Thermal Resistance Junction to Ambient | $R_{\theta JA}$ | | - | - | 115 | $^\circ C/W$ | |

Source-Drain Diode Ratings And Characteristics

| CHARACTERISTIC | SYMBOL | TEST CONDITIONS | LIMITS | | | UNITS |
|-----------------------|----------|--|--------|-----|-----|-------|
| | | | MIN | TYP | MAX | |
| Forward Voltage | V_{SD} | $I_{SD} = 2A$ | - | - | 1.2 | V |
| Reverse Recovery Time | t_{rr} | $I_{SD} = 2A, di_{SD}/dt = 100A/\mu s$ | - | - | 200 | ns |

Performance Curves

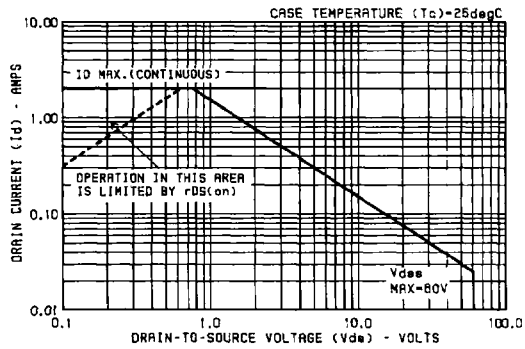

FIGURE 1. SAFE-OPERATING AREA CURVE

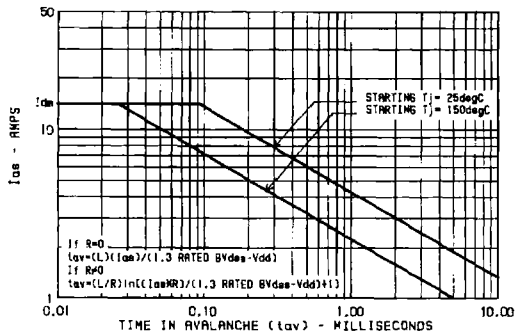

FIGURE 2. UNCLAMPED INDUCTIVE-SWITCHING

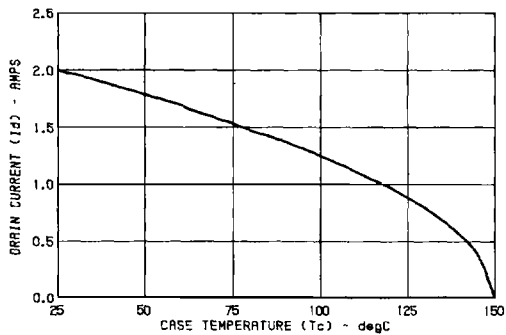

FIGURE 3. MAXIMUM CONTINUOUS DRAIN CURRENT vs TEMPERATURE

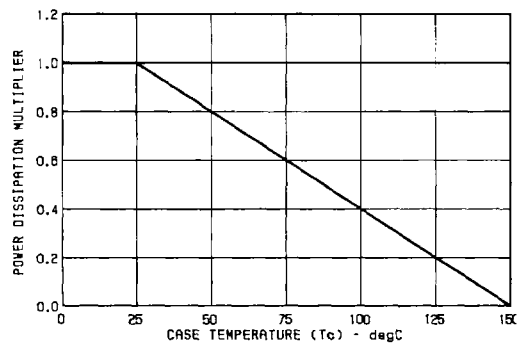

FIGURE 4. NORMALIZED POWER DISSIPATION vs TEMPERATURE DERATING CURVE

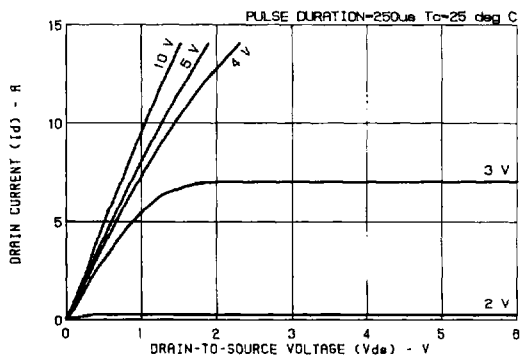

FIGURE 5. TYPICAL SATURATION CHARACTERISTICS

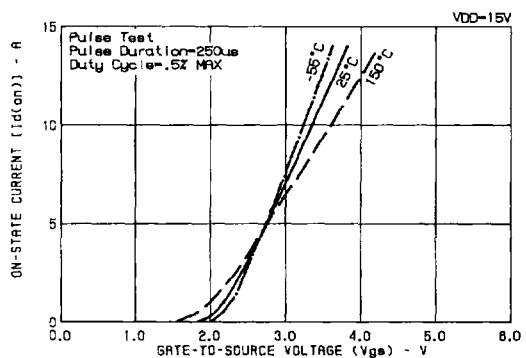

FIGURE 6. TYPICAL TRANSFER CHARACTERISTICS

6
LOGIC LEVEL
POWER MOSFETS

Performance Curves (Continued)

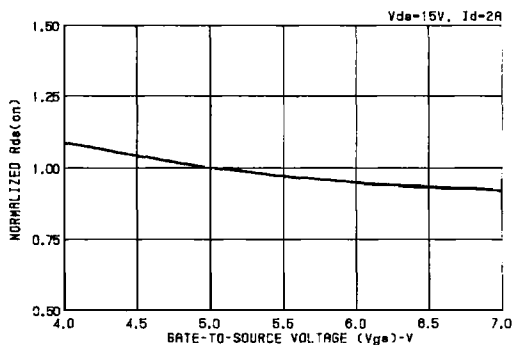

FIGURE 7. NORMALIZED $r_{DS(on)}$ vs V_{GS}

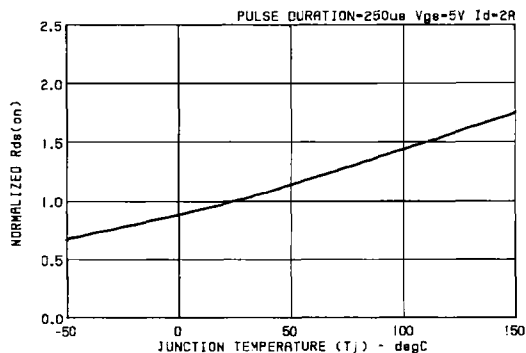

FIGURE 8. NORMALIZED $r_{DS(on)}$ vs JUNCTION TEMPERATURE

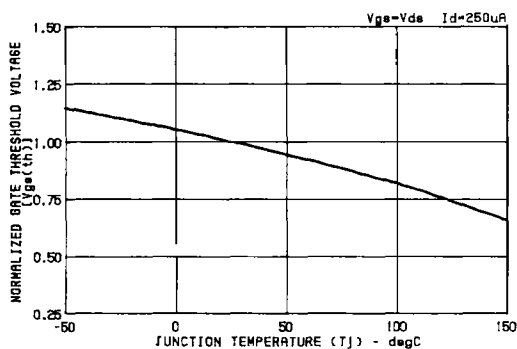

FIGURE 9. NORMALIZED GATE THRESHOLD VOLTAGE vs TEMPERATURE

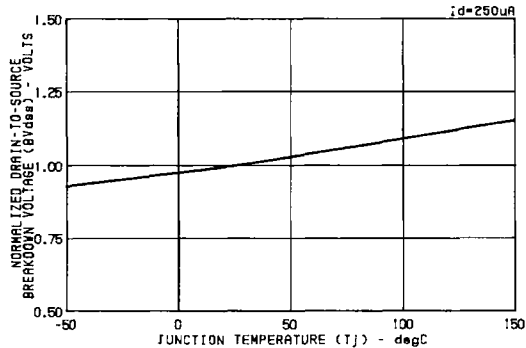

FIGURE 10. NORMALIZED DRAIN SOURCE BREAKDOWN VOLTAGE vs TEMPERATURE

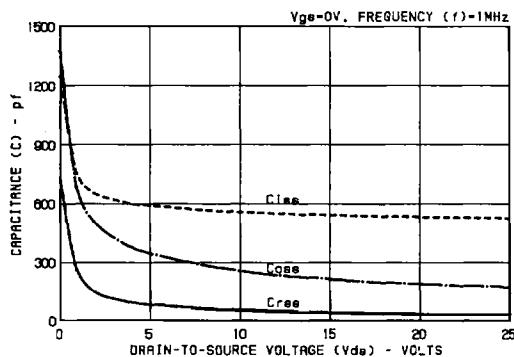

FIGURE 11. TYPICAL CAPACITANCE vs VOLTAGE

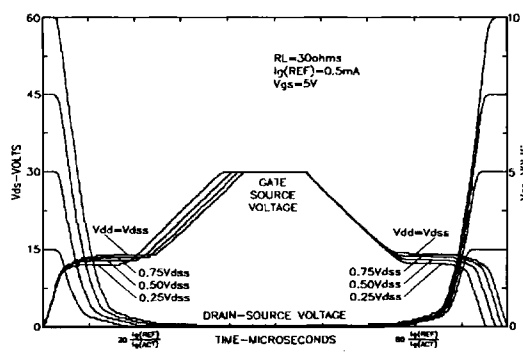

FIGURE 12. TYPICAL SWITCHING WAVEFORMS FOR CONSTANT GATE CURRENT. REFER TO APPLICATION NOTES AN7254 AND AN7260

Performance Curves (Continued)

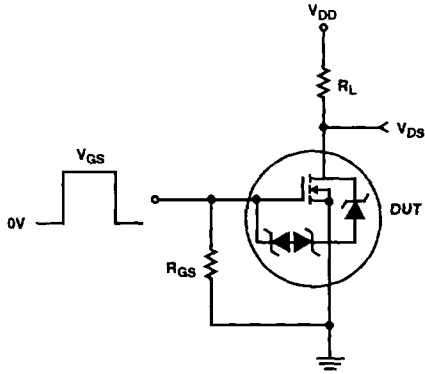

FIGURE 13. RESISTIVE SWITCHING TEST CIRCUITS

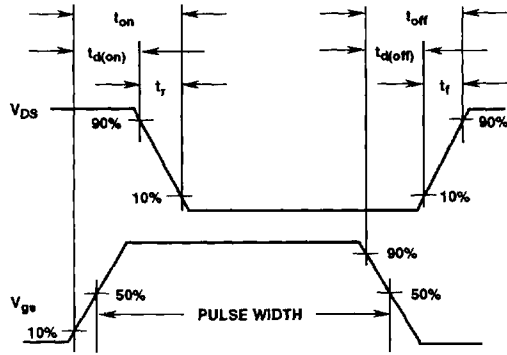
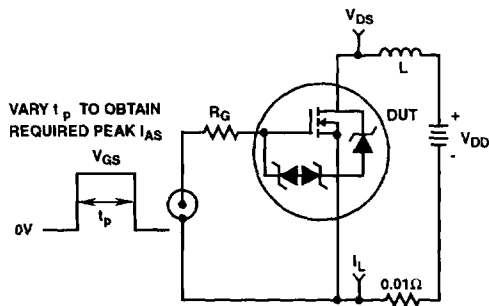

FIGURE 14. RESISTIVE SWITCHING WAVEFORMS



VARY t_p TO OBTAIN
REQUIRED PEAK I_{AS}

FIGURE 15. UNCLAMPED ENERGY TEST CIRCUIT

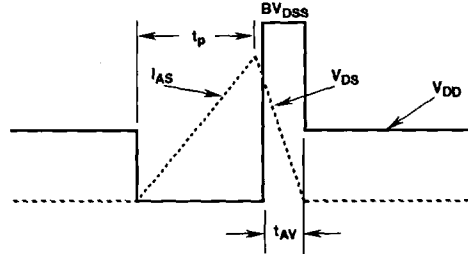

FIGURE 16. UNCLAMPED ENERGY WAVEFORMS