

REVISIONS					
REV	ECO	DESCRIPTION	DATE	BY	APPR
A2	-	UPDATE DRAWING	Aug-9-2019	Flan	Tommy
A3	-	UPDATE DRAWING	Oct-15-2019	Flan	Tommy
A4	-	UPDATE DRAWING	Nov-12-2019	Flan	Tommy
A5	-	UPDATE DRAWING	Jun-29-2020	Ronald	Tommy
A6	-	UPDATE DRAWING	Aug-15-2020	Ronald	Tommy
A7	-	UPDATE IP CLASS	Jul-8-2021	Flan	Tommy

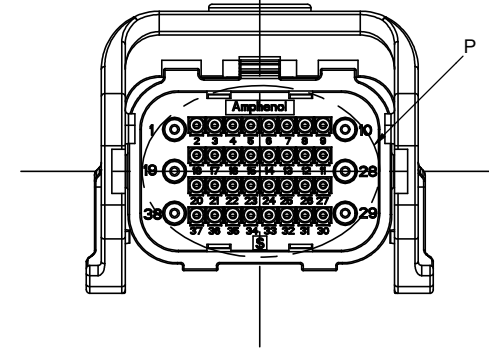

NOTES: (UNLESS OTHERWISE SPECIFIED)

- MATERIAL:
  - SHELL: THERMOPLASTIC, UL94 V-0, GRAY.
  - CONTACT LOCATING COVER: THERMOPLASTIC, UL94 V-0, GREEN.
  - GASKET: SILICONE RUBBER, RED.
  - WIRE SEAL: SILICONE RUBBER.
  - END CAP: THERMOPLASTIC, UL94 V-0, GRAY.
  - LOCKING LEVER: THERMOPLASTIC, UL94 V-0, BLACK.
- SPECIFICATIONS:
  - RATED CURRENT:
    - POWER: 13A (MAX).
    - SIGNAL: 5A (MAX).
  - RATED VOLTAGE (CLASS OF POLLUTION II): 250V (AC/DC).
  - OPERATING TEMPERATURE: -40°C~+125°C.
  - DIELECTRIC WITHSTANDING VOLTAGE: LESS THAN 2 MILLIAMPS CURRENT LEAKAGE@2000 VOLTS AC.
  - INSULATION RESISTANCE: 500 MEGOHMS MIN.
  - IP-CLASS: IP67&IP69K(MATED CONDITION).  $\triangle A7$
  - MATING CYCLES DURABILITY: 500 CYCLES.
  - RoHS COMPLIANT.
- ALL DIMENSIONS ARE FOR REFERENCE USE ONLY.
- PART NUMBER AND WIRE RANGE:  $\triangle A6$

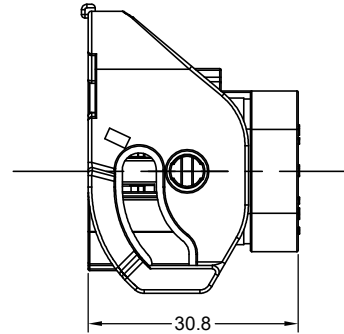
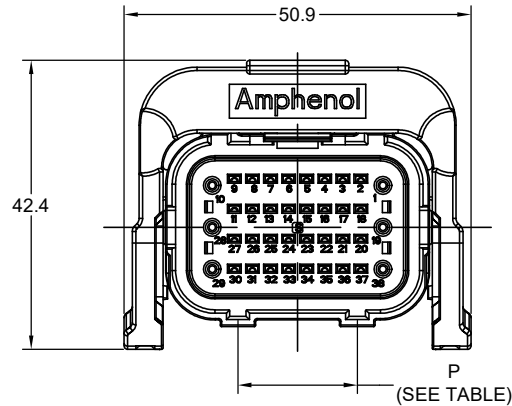
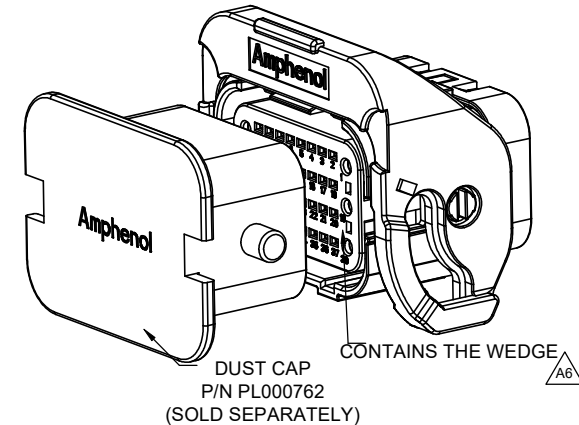
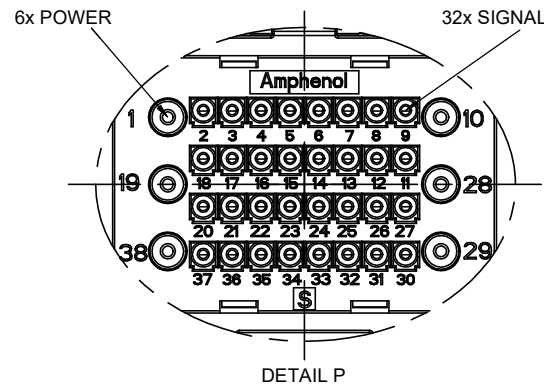

PART NUMBER	SIGNAL (WIRE&OD RANGE)	POWER (WIRE&OD RANGE)	WIRE SEAL COLOR
ATV06-38S*-S2	Ø1.5~1.8mm(20AWG)	Ø1.6~2.8mm (22~14AWG)	RED

\*\*\*DENOTES KEY WAY. CONTACT SIZE: SIGNAL SC000572x; POWER SS20M1x, SS16M1x, SS14M1x. RECOMMENDED TO CHOOSE HARD WIRE, SUCH AS FEP INSULATION AND XLPE INSULATION.

TABLE

KEY POS	P
A	17.50
B	14.50
C	11.50

QUANTITY	PART NUMBER	DESCRIPTION	ITEM
<b>MATERIALS LIST</b>			
<b>UNLESS OTHERWISE SPECIFIED</b> 1) All dimensions are in metric (mm). 2) Tolerances are as follows: 1 PL DEC ±0.30 2 PL DEC ±0.15 3 PL DEC ±0.08 3) Note reference = $\triangle$		<b>SIGNATURES</b> DRAWN: Flan CHECKED: Orion ENGINEER: APPROVAL: Tommy DATE: Jul-8-2021 Jul-9-2021 Jul-9-2021	<b>Amphenol</b> Sine Systems - www.amphenol-sine.com 44724 Morley Drive Clinton Township, MI 48036
MATERIAL SPECIFICATIONS:		APPROVAL: Tommy	DURALOK ,ATV,PLUG,38POS,SOCKET
PROCESS SPECIFICATIONS:		CUSTOMER:	THIS DRAWING IS SUPPLIED FOR INFORMATION ONLY. DESIGN FEATURES, SPECIFICATIONS AND PERFORMANCE DATA SHOWN HEREON ARE THE PROPERTY OF THE AMPHENOL CORPORATION. NO RIGHTS OF REPRODUCTION ARE IMPLIED. ALL DIMENSIONS ARE SUBJECT TO NORMAL MANUFACTURING VARIATIONS.
NEXT ASSY:	SIZE: B C-	DWG NO: ATV06-38S*-Sx	REVISION: A7
	SCALE: NONE		SHEET 1 OF 1

TITLE: DURALOK ,ATV,PLUG,38POS,SOCKET  
 DWG NO: ATV06-38S\*-Sx  
 REV: A7  
 SH: 1  
 OF: 1

# DuraLok™ - Contact Options

Stamped & Formed , Crimp Contacts				
Part Number		Contact Size (AWG)	Wire Range (mm²)	Plating
Male	Female			
SP14M2F	SS14M2F	14AWG	2.0-2.5mm²	Gold Flash 1µ"
SP14M2G5	SS14M2G5	14AWG	2.0-2.5mm²	Gold 5µ"
SP14M2G10	SS14M2G10	14AWG	2.0-2.5mm²	Gold 10µ"
SP14M2G15	SS14M2G15	14AWG	2.0-2.5mm²	Gold 15µ"
SP14M2G30	SS14M2G30	14AWG	2.0-2.5mm²	Gold 30µ"
SP14M2T	SS14M2T	14-16AWG	2.0-2.5mm²	Tin over Nickel
SP16M2F	SS16M2F	16-18AWG	0.75-1.5mm²	Gold Flash 1µ"
SP16M2G5	SS16M2G5	16-18AWG	0.75-1.5mm²	Gold 5µ"
SP16M2G10	SS16M2G10	16-18AWG	0.75-1.5mm²	Gold 10µ"
SP16M2G15	SS16M2G15	16-18AWG	0.75-1.5mm²	Gold 15µ"
SP16M2G30	SS16M2G30	16-18AWG	0.75-1.5mm²	Gold 30µ"
SP16M2T	SS16M2T	16-18AWG	0.75-1.5mm²	Gold 30µ"
SP20M2F	SS20M2F	20-22AWG	0.34-0.50mm²	Gold Flash 1µ"
SP20M2G5	SS20M2G5	20-22AWG	0.34-0.50mm²	Gold 5µ"
SP20M2G10	SS20M2G10	20-22AWG	0.34-0.50mm²	Gold 10µ"
SP20M2G15	SS20M2G15	20-22AWG	0.34-0.50mm²	Gold 15µ"
SP20M2G30	SS20M2G30	20-22AWG	0.34-0.50mm²	Gold 30µ"
SP20M2T	SF20M2T	20-22AWG	0.34-0.50mm²	Tin over Nickel
SC000571T	SC000572T	20-22AWG	0.34-0.50mm²	Tin
SC000571F	SC000572F	20-22AWG	0.34-0.50mm²	Gold Flash 1µ"
SC000571G5	SC000572G5	20-22AWG	0.34-0.50mm²	Gold 5µ"
SC000571G10	SC000572G10	20-22AWG	0.34-0.50mm²	Gold 10µ"
SC000571G15	SC000572G15	20-22AWG	0.34-0.50mm²	Gold 15µ"
SC000571G30	SC000572G30	20-22AWG	0.34-0.50mm²	Gold 30µ"
SC000571N	SC000572N	20-22AWG	0.34-0.50mm²	Nickel

Stamped & Formed, Tooling	
Part Number	Description
ATT-571-P	Hand Tool, Stamped & Formed, Pin, 571 Series Contacts
ATT-572-S	Hand Tool, Stamped & Formed, Socket, 572 Series Contacts
CA-4020-59	Sealing Plug, Size 16 & 20
MFX-3954	Hand Tool, Stamped & Formed Contact, Size 16, 14-20AWG
MFX-3957	Crimp Die, Stamped & Formed Contact
MFX-4017-G or K	Crimp Die, Stamped & Formed Contact, SC000571
MFX-4018-G or K	Crimp Die, Stamped & Formed Contact, SC000572
QXRT16	Contact Extraction Tool, #16 (Ø 1.6) Contact

Standard Quantity Order Options	
Machined	Bulk Package, 500 Pieces
Stamped & Formed	Reel, 3000 Pieces

Plating Options	
Symbol	Plating
T	Tin Plated (for Stamped & Formed Contacts)
S	Silver Plated 5Um (for Machined Contacts)
F	Gold Flash (Thickness 1µ")
G5	Gold Plated (Thickness 5µ")
G10	Gold Plated (Thickness 10µ")
G15	Gold Plated (Thickness 15µ")
G30	Gold Plated (Thickness 30µ")