

1. 製品名称 / PRODUCT NAME : MINI-LOCK 2.5 W/B CONN CRIMP REC

製品番号 / PART NUMBER : 5 0 7 5 2 8 2 0 0

5 0 7 5 2 8 4 0 0

2. 標準個数 / STANDARD PACKAGING QUANTITY.

1リールの巻き数 QTY. PER REEL	カートン中のリール数 NUMBER OF REELS	1カートンの製品数 QUANTITY IN ONE CARTON
10,000	4	40,000

3. リール外形参考寸法 / REEL OUTER DIMENSIONS (REFERENCE PURPOSE ONLY)

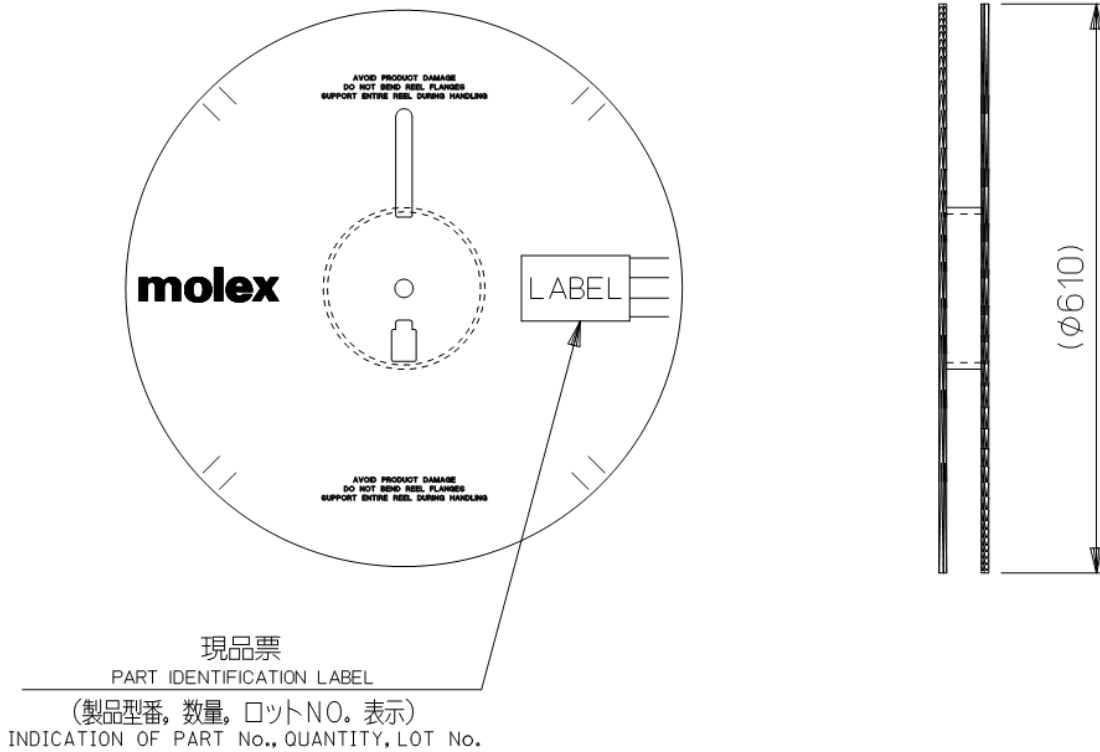

THIS DOCUMENT CONTAINS INFORMATION THAT IS PROPRIETARY TO MOLEX ELECTRONIC TECHNOLOGIES, LLC AND SHOULD NOT BE USED WITHOUT WRITTEN PERMISSION

REVISION DESCRIPTION	ADDED REEL ASSEMBLY DETAILS			5 0 7 5 2 梱包仕様書 SALES PACKAGING SPEC. FOR 50752			
CHANGE NO.	649813			DOC TYPE	DOC TYPE DESCRIPTION	DOC PART	SERIES
REVISED BY	PUNITM	DATE	2020/11/19	PS	APPLICATION SPECIFICATION WORD	200	50752
REV APPR BY	AIDA	DATE	2020/11/30	INITIAL RELEASE		REVISION	SHEET
INITIAL DRWN	YTOKUZONO	DATE	2018/05/09	CUSTOMER	DOCUMENT NUMBER	A1	1 OF 2
INITIAL APPR	M.SASAO	DATE	2018/05/09	LEAR CORPORATION	507529200-SPK		

4. リールアセンブリの詳細/REEL ASSEMBLY DETAILS

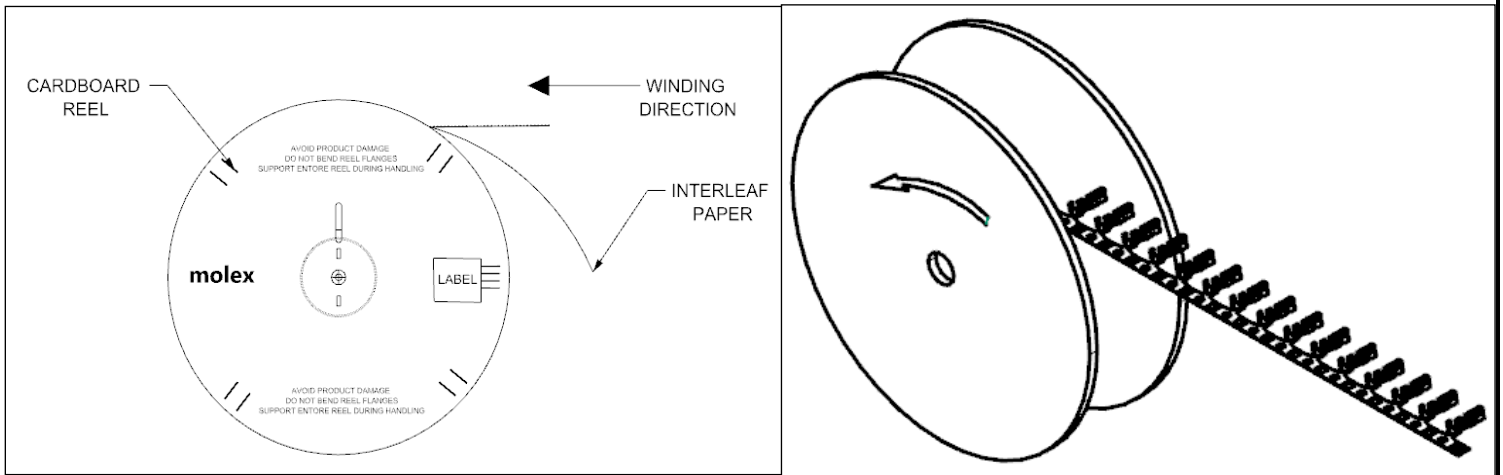

5. カートン外形参考寸法/CARTON OUTER DIMENSIONS (REFERENCE PURPOSE ONLY) 単位/UNIT: mm

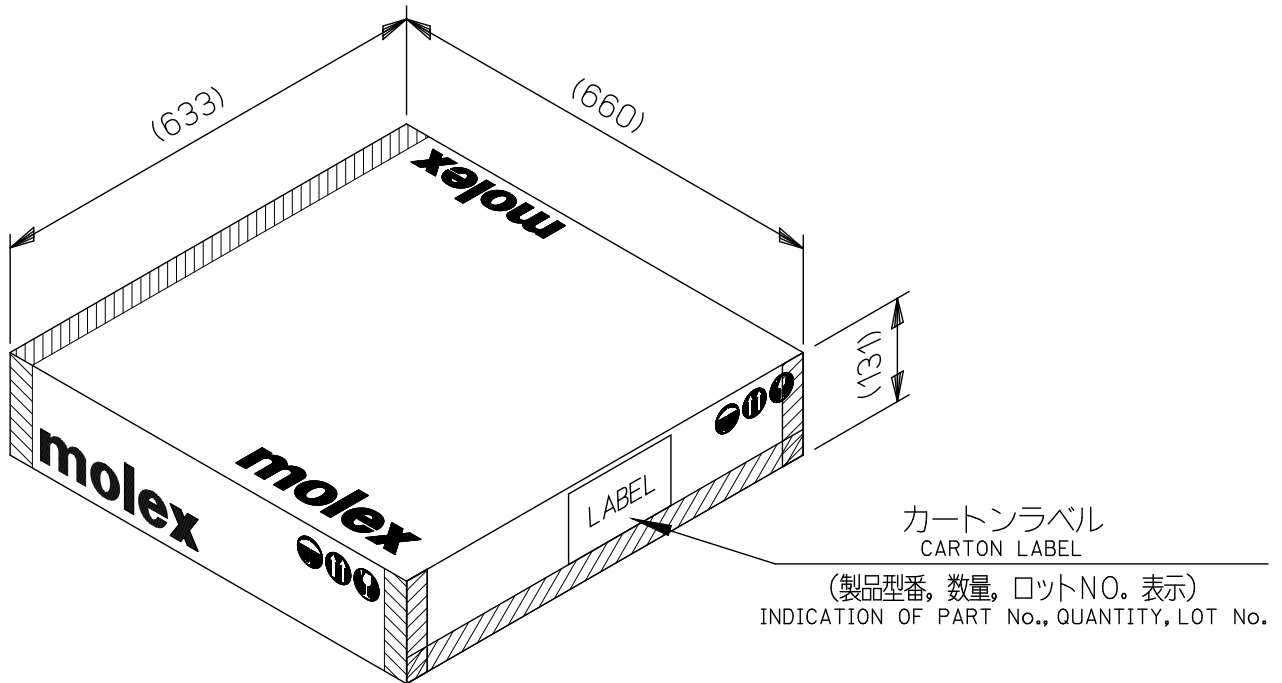

THIS DOCUMENT CONTAINS INFORMATION THAT IS PROPRIETARY TO MOLEX ELECTRONIC TECHNOLOGIES, LLC AND SHOULD NOT BE USED WITHOUT WRITTEN PERMISSION

REVISION DESCRIPTION	ADDED REEL ASSEMBLY DETAILS			5 0 7 5 2 梱包仕様書 SALES PACKAGING SPEC. FOR 50752			
CHANGE NO.	649813						
REVISED BY	PUNITM	DATE	2020/11/19	DOC TYPE	DOC TYPE DESCRIPTION	DOC PART	SERIES
REV APPR BY	AIDA	DATE	2020/11/30	PS	APPLICATION SPECIFICATION WORD	200	50752
INITIAL RELEASE				CUSTOMER		DOCUMENT NUMBER	
INITIAL DRWN	YTOKUZONO	DATE	2018/05/09	LEAR CORPORATION	507529200-SPK	A1	2 OF 2
INITIAL APPR	M.SASAO	DATE	2018/05/09				