

■ Features

- Complementary to MMBT5551
- Power Dissipation of 300mW
- High Stability and High Reliability
- Transistor(PNP)

■ Mechanical Data

- package:SOT-23
- Flammability rating of epoxy resin: UL 94V-0
- Mounting Position: Any

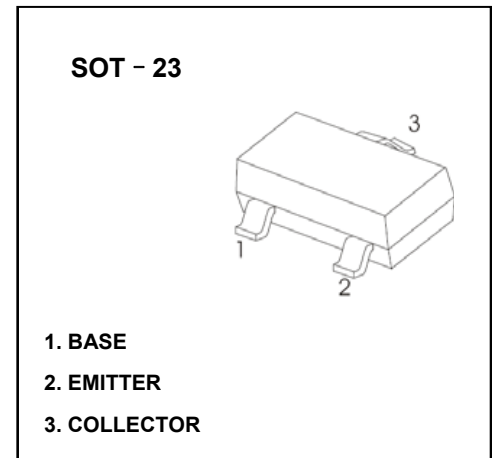

■ Ordering Information

Part Number	Package	Marking	Packing	Quantity per reel	Reel Size
MMBT5401	SOT-23	2L	Tape & Reel	3,000 PCS	7 inches

■ Maximum Ratings & Thermal Characteristics(Ratings at 25 °C ambient temperature unless otherwise specified.)

Parameters	Symbol	Value	Unit
Collector-Base Voltage	V _{CB0}	-160	V
Collector-Emitter Voltage	V _{CEO}	-150	V
Emitter -Base Voltage	V _{EBO}	-5	V
Collector Current-Continuous	I _c	-600	mA
Collector Power Dissipation	P _c	300	mW
Junction Temperature	T _j	150	°C
Storage Temperature	T _{stg}	-55-+150	°C
Thermal resistance From junction to ambient	R _{θJA}	416	°C/W

Electrical Characteristics(Ratings at 25°C ambient temperature unless otherwise specified)

Parameter	Symbols	Test Condition	Limits		Unit
			Min	Max	
Collector-base breakdown voltage	V(BR)CBO	IC=-100uA, IE=0	-160		V
Collector-emitter breakdown voltage	V(BR)CEO *	IC=-1mA, IB=0	-150		V
Emitter-base breakdown voltage	V(BR)EBO	IE=-10uA, IC=0	-5		V
Collector cut-off current	ICBO	VCE=-120V, IE=0		-100	nA
Emitter cut-off current	IEBO	VEB=-4V, IC=0		-100	nA
DC current gain	hFE(1) *	VCE=-5V, IC=-1mA	80		
	hFE(2) *	VCE=-5V, IC=-10mA	100	300	
	hFE(3) *	VCE=-5V, IC=-50mA	30		
Collector-emitter saturation voltage	VCE(sat)1 *	IC=-10mA, IB=-1mA		-0.2	V
	VCE(sat)2 *	IC=-50mA, IB=-5mA		-0.5	V
Base -emitter saturation voltage	VBE(sat)1 *	IC=-10mA, IB=-1mA		-1.00	V
	VBE(sat)2 *	IC=-50mA, IB=-5mA		-1.00	V
Transition frequency	fT	VCE=-5V, IC=10mA, f=30MHz	100		MHz

*Pulse test: pulse width ≤300μs, duty cycle≤ 2.0%.

CLASSIFICATION OF hFE(2)

HFE	100-300	
RANK	L	H
RANGE	100-200	200-300



■ Typical Characteristics

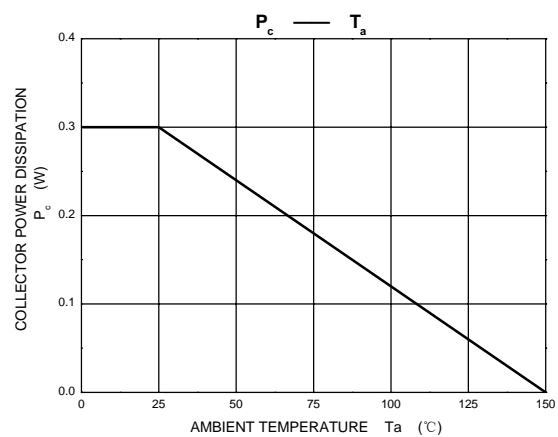
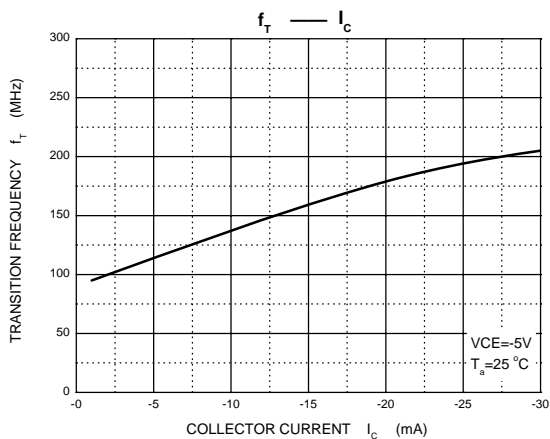
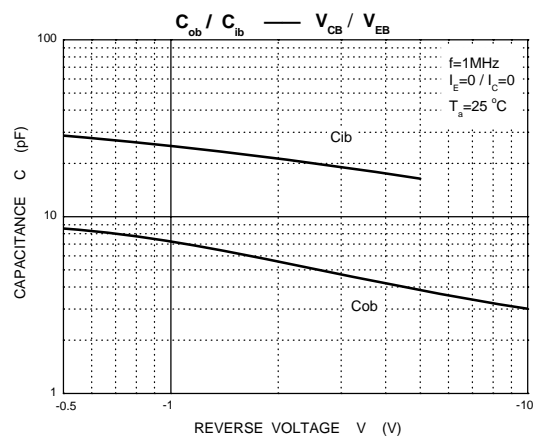
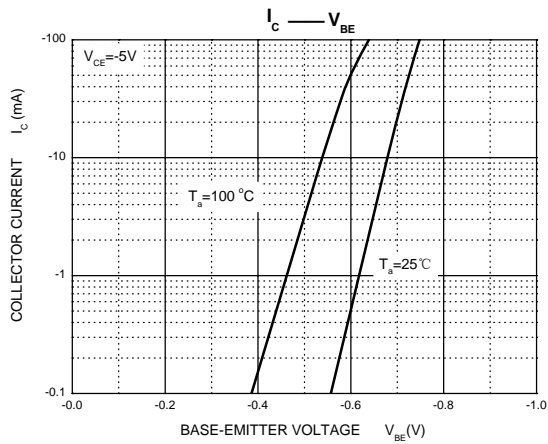
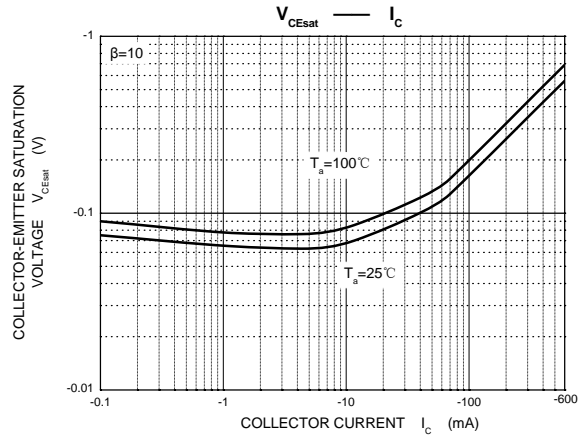
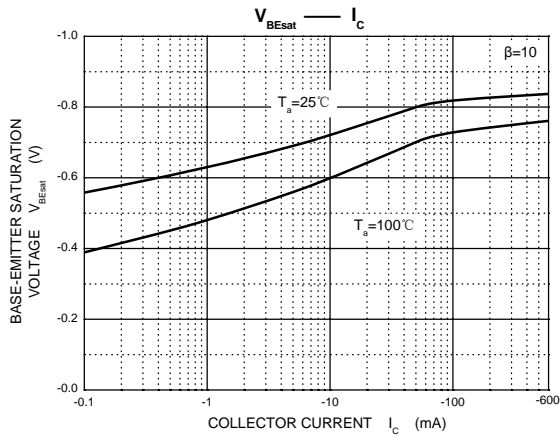
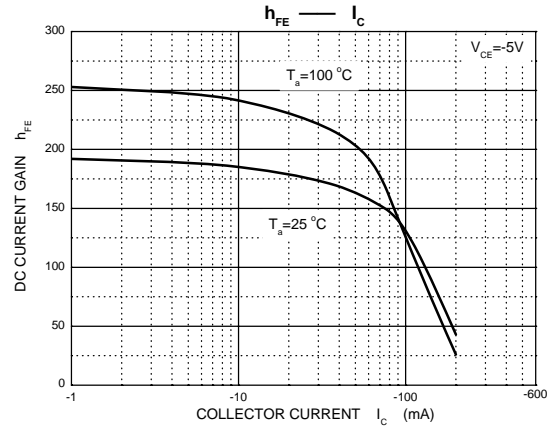
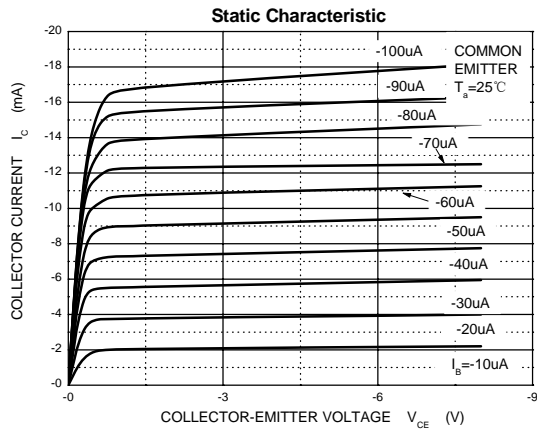



■ SOT-23 Package Outline Dimensions

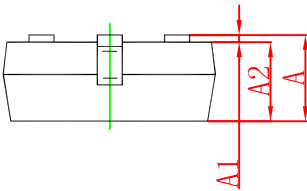
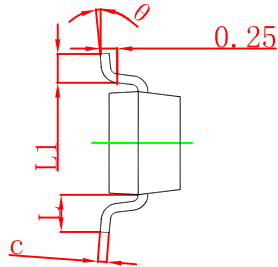
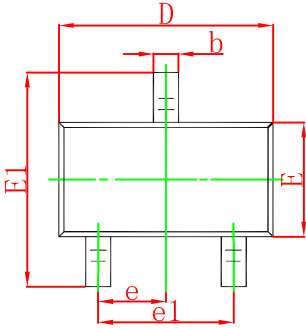

Symbol	Dimensions In Millimeters		Dimensions In Inches	
	Min	Max	Min	Max
A	0.900	1.150	0.035	0.045
A1	0.000	0.100	0.000	0.004
A2	0.900	1.050	0.035	0.041
b	0.300	0.500	0.012	0.020
c	0.080	0.150	0.003	0.006
D	2.800	3.000	0.110	0.118
E	1.200	1.400	0.047	0.055
E1	2.250	2.550	0.089	0.100
e	0.950 TYP		0.037 TYP	
e1	1.800	2.000	0.071	0.079
L	0.550 REF		0.022 REF	
L1	0.300	0.500	0.012	0.020
θ	0°	8°	0°	8°