

■ Features

- Complementary to MMBT3906T
- Power Dissipation of 150mW
- High Stability and High Reliability
- Transistor(NPN)

■ Mechanical Data

- package:SOT-523
- Flammability rating of epoxy resin: UL 94V-0
- Mounting Position: Any

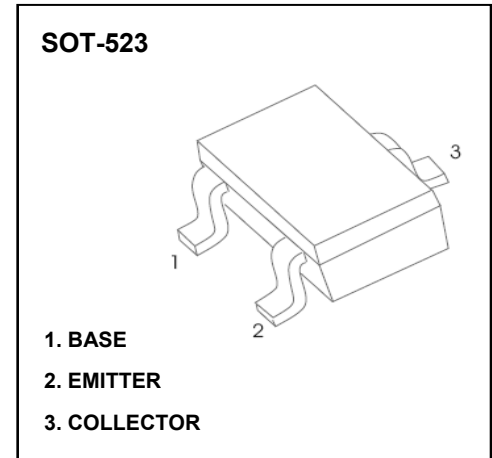

■ Ordering Information

Part Number	Package	Marking	Packing	Quantity per reel	Reel Size
MMBT3904T	SOT-523	1N	Tape & Reel	3,000 PCS	7 inches

■ Maximum Ratings & Thermal Characteristics(Ratings at 25°C ambient temperature unless otherwise specified.)

Parameters	Symbol	Value	Unit
Collector-Base Voltage	V _{CB0}	60	V
Collector-Emitter Voltage	V _{CE0}	40	V
Emitter -Base Voltage	V _{EB0}	6	V
Collector Current-Continuous	I _c	200	mA
Collector Power Dissipation	P _c	150	mW
Junction Temperature	T _j	150	°C
Storage Temperature	T _{stg}	-55-+150	°C
Thermal resistance From junction to ambient	R _{θJA}	833	°C/W

Electrical Characteristics(Ratings at 25°C ambient temperature unless otherwise specified)

Parameter	Symbols	Test Condition	Limits		Unit
			Min	Max	
Collector-base breakdown voltage	V(BR)CBO	IC=10uA, IE=0	60		V
Collector-emitter breakdown voltage	V(BR)CEO	IC=1mA, IB=0	40		V
Emitter-base breakdown voltage	V(BR)EBO	IE=10uA, IC=0	6		V
Collector cut-off current	ICEX	VCE=30V, VEB(off)=3V		50	nA
Emitter cut-off current	IEBO	VEB=5V, IC=0		100	nA
DC current gain	hFE(1)	VCE=1V, IC=0.1mA	40		
	hFE(2)	VCE=1V, IC=1mA	70		
	hFE(3)	VCE=1V, IC=10mA	100	300	
	hFE(4)	VCE=1V, IC=50mA	60		
Collector-emitter saturation voltage	VCE(sat)	IC=10mA, IB=1mA		0.20	V
		IC=50mA, IB=5mA		0.30	V
Base -emitter saturation voltage	VBE(sat)	IC=10mA, IB=1mA	0.65	0.85	V
		IC=50mA, IB=5mA		0.95	V
Transition frequency	f_r	VCE=20V, IC=10mA, f=100MHz	300		MHz
Collector output capacitance	C_{ob}	VCB=5V, IE=0, f=1MHz		4	pF
	C_{ib}	VEB=5V, IE=0, f=1MHz		8	pF
Delay time	t_d	VCC=3V, VBE(off)=-0.5V, IC=10mA, IB1=1mA		35	nS
Rise time	t_r			35	nS
Storage time	t_s	VCC=3V, IC=10mA, IB1=IB2=1mA		200	nS
Fall time	t_f			50	nS

*Pulse test: pulse width≤300us,duty cycle≤2.0%



■ Typical Characteristics

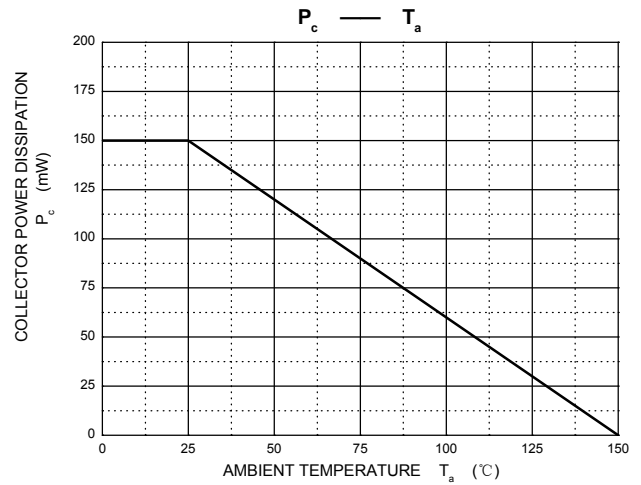
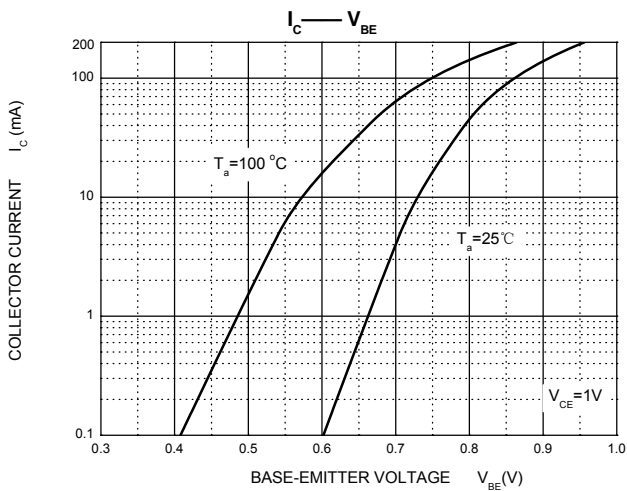
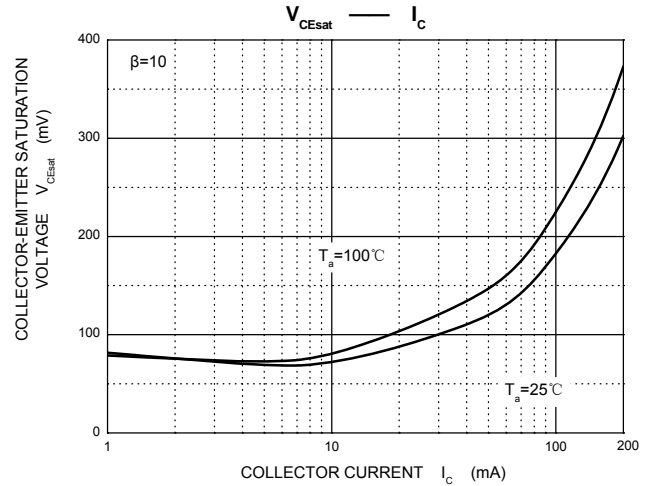
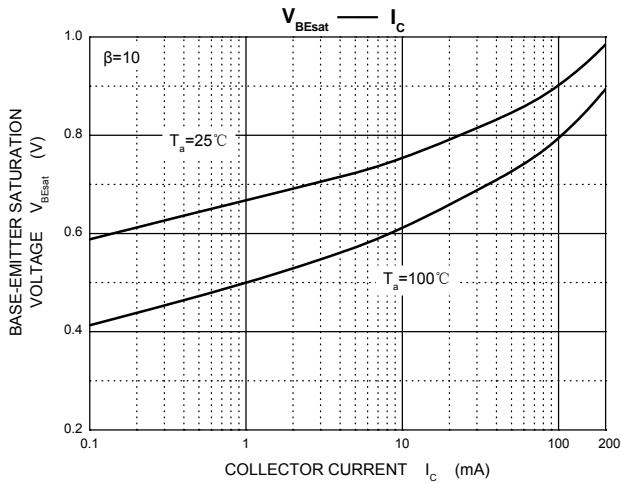
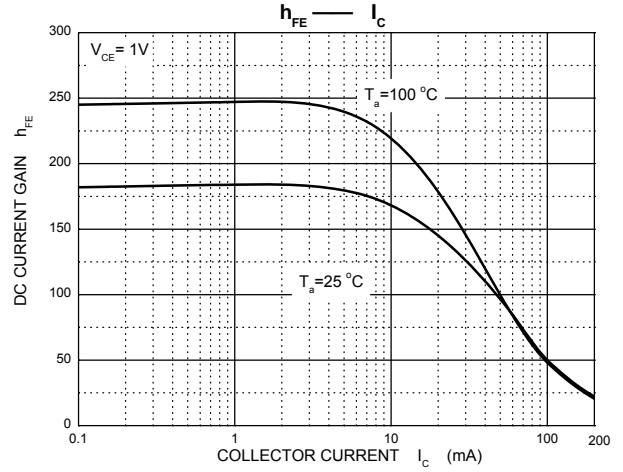
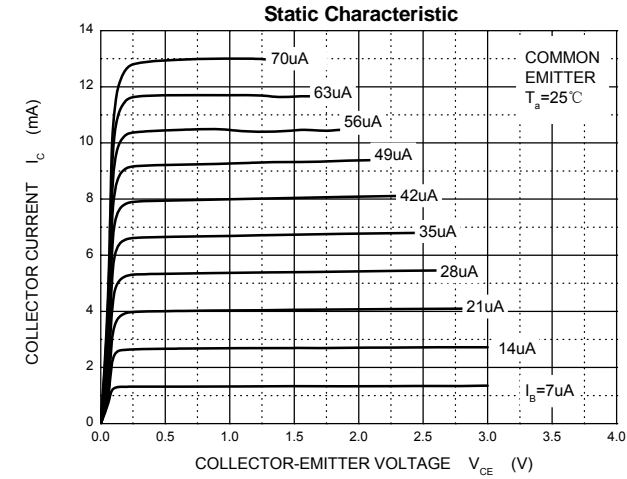



■ SOT-523 Package Outline Dimensions

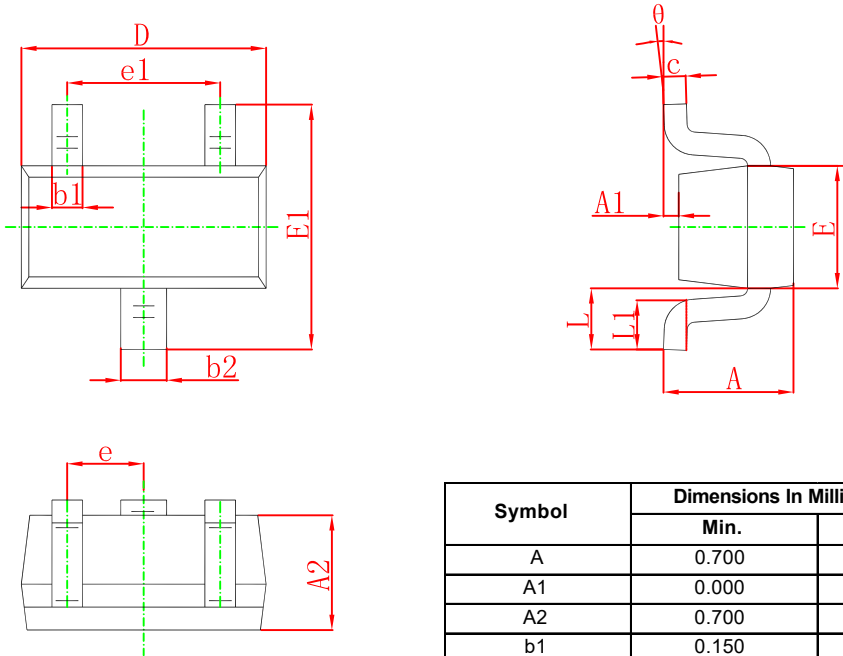

Symbol	Dimensions In Millimeters		Dimensions In Inches	
	Min.	Max.	Min.	Max.
A	0.700	0.900	0.028	0.035
A1	0.000	0.100	0.000	0.004
A2	0.700	0.800	0.028	0.031
b1	0.150	0.250	0.006	0.010
b2	0.250	0.350	0.010	0.014
c	0.100	0.200	0.004	0.008
D	1.500	1.700	0.059	0.067
E	0.700	0.900	0.028	0.035
E1	1.450	1.750	0.057	0.069
e	0.500 TYP.		0.020 TYP.	
e1	0.900	1.100	0.035	0.043
L	0.400 REF.		0.016 REF.	
L1	0.260	0.460	0.010	0.018
θ	0°	8°	0°	8°