



# SN74HC/HCT192

## Presettable Synchronous BCD Decade up/down Counter; Asynchronous Reset

### Product Specification

#### Specification Revision History:

Version	Date	Description
2012-06-A1	2012-06	New
2021-12-A2	2021-12	Modify Ordering Information



## 1、General Description

The SN74HC/HCT192 is a synchronous BCD up/down counter. Separate up/down clocks, CPU and CPD respectively, simplify operation. The outputs change state synchronously with the LOW-to-HIGH transition of either clock input. If the CPU clock is pulsed while CPD is held HIGH, the device will count up. If the CPD clock is pulsed while CPU is held HIGH, the device will count down. Only one clock input can be held HIGH at any time to guarantee predictable behavior. The device can be cleared at any time by the asynchronous master reset input (MR); it may also be loaded in parallel by activating the asynchronous parallel load input (PL).

The terminal count up (TCU) and terminal count down (TCD) outputs are normally HIGH. When the circuit has reached the maximum count state of 15, the next HIGH-to-LOW transition of CPU will cause TCU to go LOW. TCU will stay LOW until CPU goes HIGH again, duplicating the count up clock.

Likewise, the TCD output will go LOW when the circuit is in the zero state and the CPD goes LOW. The terminal count outputs can be used as the clock input signals to the next higher order circuit in a multistage counter, since they duplicate the clock waveforms. Multistage counters will not be fully synchronous, since there is a slight delay time difference added for each stage that is added.

The counter may be preset by the asynchronous parallel load capability of the circuit. Information present on the parallel data inputs (D0 to D3) is loaded into the counter and appears on the outputs (Q0 to Q3) regardless of the conditions of the clock inputs when the parallel load (PL) input is LOW. A HIGH level on the master reset (MR) input will disable the parallel load gates, override both clock inputs and set all outputs (Q0 to Q3) LOW. If one of the clock inputs is LOW during and after a reset or load operation, the next LOW-to-HIGH transition of that clock will be interpreted as a legitimate signal and will be counted. Inputs include clamp diodes. This enables the use of current limiting resistors to interface inputs to voltages in excess of  $V_{CC}$ .

### Features:

- Input levels:
  - For SN74HC192: CMOS level
  - For SN74HCT192: TTL level
- Synchronous reversible counting
- Asynchronous parallel load
- Asynchronous reset
- Expandable without external logic
- Specified from  $-40^{\circ}\text{C}$  to  $+85^{\circ}\text{C}$
- Packaging information: DIP16/SOP16/TSSOP16



## Ordering Information:

### Tube packing specifications:

Part number	Packaging form	Marking code	Tube quantity	Boxed tube quantity	Boxed quantity	Notes
SN74HC192N (LX)	DIP16	SN74HC192N	25 PCS/tube	40 tube/box	1000 PCS/box	Dimensions of plastic enclosure: 19.0mm×6.4mm Pin spacing: 2.54mm
SN74HCT192N (LX)	DIP16	SN74HCT192N	25 PCS/tube	40 tube/box	1000 PCS/box	Dimensions of plastic enclosure: 19.0mm×6.4mm Pin spacing: 2.54mm

### Reel packing specifications:

Part number	Packaging form	Marking code	Reel quantity	Boxed reel quantity	Notes
SN74HC192DR (LX)	SOP16	HC192	2500 PCS/reel	8000 PCS/box	Dimensions of plastic enclosure: 10.0mm×3.9mm Pin spacing: 1.27mm
SN74HCT192DR (LX)	SOP16	HCT192	2500 PCS/reel	8000 PCS/box	Dimensions of plastic enclosure: 10.0mm×3.9mm Pin spacing: 1.27mm
SN74HC192PW (LX)	TSSOP16	SN74HC192	5000 PCS/reel	10000 PCS/box	Dimensions of plastic enclosure: 5.0mm×4.4mm Pin spacing: 0.65mm
SN74HCT192PW (LX)	TSSOP16	SN74HCT192	5000 PCS/reel	10000 PCS/box	Dimensions of plastic enclosure: 5.0mm×4.4mm Pin spacing: 0.65mm

Note: If the physical information is inconsistent with the ordering information, please refer to the actual product.



## 2、Block Diagram And Pin Description

### 2.1、Block Diagram

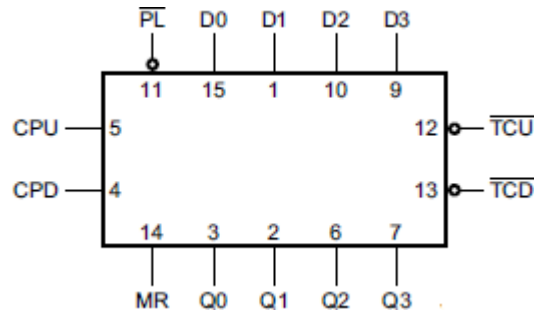

Figure 1. Logic symbol

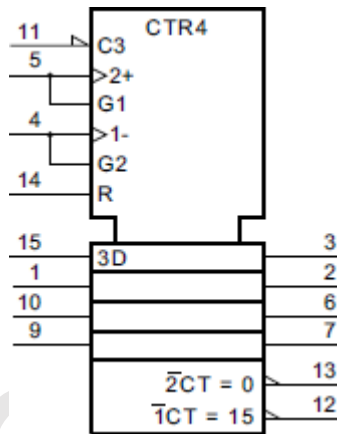

Figure 2. IEC logic symbol

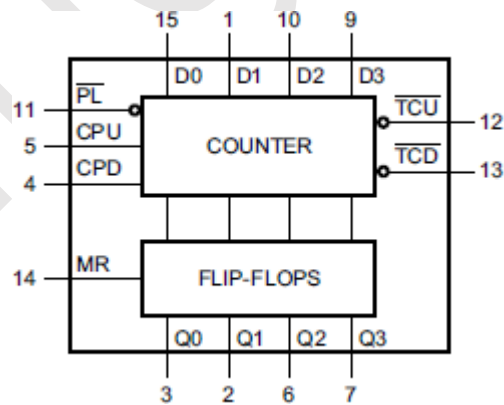

Figure 3. Functional diagram

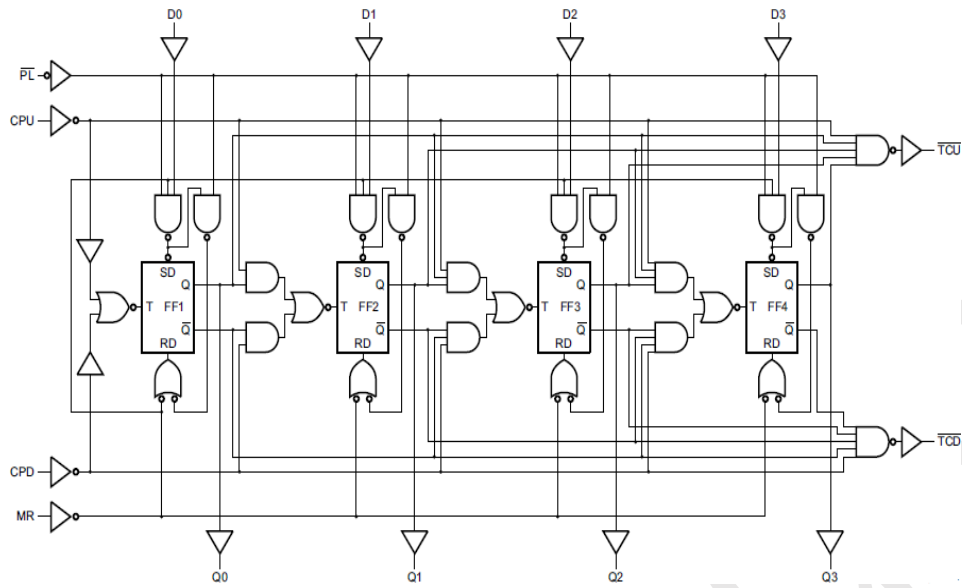

Figure 4. Logic diagram

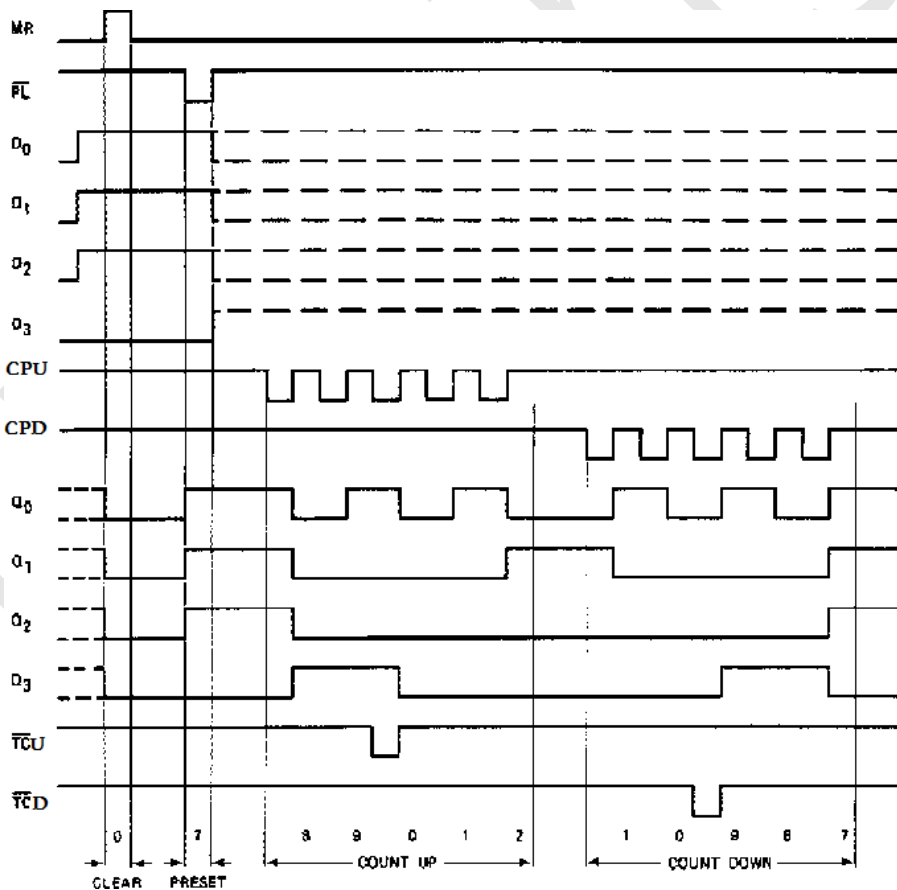
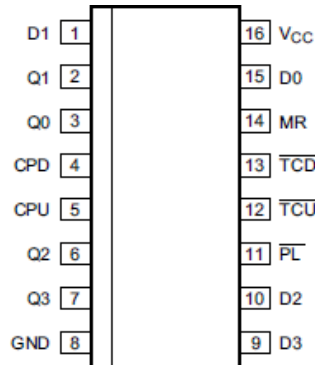

Figure 5. Typical clear, load and count sequence



## 2.2、Pin Configurations



## 2.3、Pin Description

Pin No.	Pin Name	Description
1	D1	data input 1
2	Q1	flip-flop output 1
3	Q0	flip-flop output 0
4	CPD	count down clock input
5	CPU	count up clock input
6	Q2	flip-flop output 2
7	Q3	flip-flop output 3
8	GND	ground (0V)
9	D3	data input 3
10	D2	data input 2
11	PL	asynchronous parallel load input (active LOW)
12	TCU	terminal count up (carry) output (active LOW)
13	TCD	terminal count down (borrow) output (active LOW)
14	MR	asynchronous master reset input (active HIGH)
15	D0	data input 0
16	V <sub>CC</sub>	supply voltage

Note: CPD, CPU is LOW-to-HIGH, edge triggered.



## 2.4、Function Table

Operating mode	Input								Output					
	MR	PL	CPU	CPD	D0	D1	D2	D3	Q0	Q1	Q2	Q3	TCU	TCD
reset (clear)	H	X	X	L	X	X	X	X	L	L	L	L	H	L
	H	X	X	H	X	X	X	X	L	L	L	L	H	H
parallel load	L	L	X	L	L	L	L	L	L	L	L	L	H	L
	L	L	X	H	L	L	L	L	L	L	L	L	H	H
	L	L	L	X	H	X	X	H	Qn=Dn			L	H	
	L	L	H	X	H	X	X	H	Qn=Dn			H	H	
count up	L	H	↑	H	X	X	X	X	count up			H	H	
count down	L	H	H	↑	X	X	X	X	count down			H	H	

Note:

[1] H=HIGH voltage level; L=LOW voltage level; X=don't care; ↑=LOW-to-HIGH transition.

[2] TCU=CPU at terminal count up (HLLH).

[3] TCD=CPD at terminal count down (LLLL).

## 3、Electrical Parameter

### 3.1、Absolute Maximum Ratings

(Voltages are referenced to GND(ground=0V), unless otherwise specified.)

Parameter	Symbol	Conditions	Min.	Max.	Unit
supply voltage	V <sub>CC</sub>	-	-0.5	+7.0	V
input clamping current	I <sub>IK</sub>	V <sub>I</sub> < -0.5V or V <sub>I</sub> > V <sub>CC</sub> +0.5V	-	±20	mA
output clamping current	I <sub>OK</sub>	V <sub>O</sub> < -0.5V or V <sub>O</sub> > V <sub>CC</sub> +0.5V	-	±20	mA
output current	I <sub>O</sub>	V <sub>O</sub> = -0.5V to (V <sub>CC</sub> +0.5V)	-	±25	mA
supply current	I <sub>CC</sub>	-	-	50	mA
ground current	I <sub>GND</sub>	-	-	-50	mA
storage temperature	T <sub>stg</sub>	-	-65	+150	°C
total power dissipation	P <sub>tot</sub>	-	-	500	mW
Soldering temperature	T <sub>L</sub>	10s	DIP	245	°C
			SOP	250	

Note:

[1] For DIP16 packages: above 70°C the value of P<sub>tot</sub> derates linearly with 12mW/K.

[2] For SOP16 packages: above 70°C the value of P<sub>tot</sub> derates linearly with 8mW/K.

[3] For (T)SSOP16 packages: above 60°C the value of P<sub>tot</sub> derates linearly with 5.5mW/K.



### 3.2、Recommended Operating Conditions

Parameter	Symbol	Conditions	Min.	Typ.	Max.	Unit	
SN74HC192							
supply voltage	$V_{CC}$	-	2.0	5.0	6.0	V	
input voltage	$V_I$	-	0	-	$V_{CC}$	V	
output voltage	$V_O$	-	0	-	$V_{CC}$	V	
input transition rise and fall rate	$\Delta t/\Delta V$	-	$V_{CC}=2.0V$	-	-	625	ns/V
			$V_{CC}=4.5V$	-	1.67	139	ns/V
			$V_{CC}=6.0V$	-	-	83	ns/V
ambient temperature	$T_{amb}$	-	-40	-	+85	°C	
SN74HCT192							
supply voltage	$V_{CC}$	-	4.5	5.0	5.5	V	
input voltage	$V_I$	-	0	-	$V_{CC}$	V	
output voltage	$V_O$	-	0	-	$V_{CC}$	V	
input transition rise and fall rate	$\Delta t/\Delta V$	-	$V_{CC}=2.0V$	-	-	-	ns/V
			$V_{CC}=4.5V$	-	1.67	139	ns/V
			$V_{CC}=6.0V$	-	-	-	ns/V
ambient temperature	$T_{amb}$	-	-40	-	+85	°C	

### 3.3、Electrical Characteristics

#### 3.3.1、DC Characteristics 1

( $T_{amb}=25^{\circ}C$ , voltages are referenced to GND (ground=0V), unless otherwise specified.)

Parameter	Symbol	Conditions	Min.	Typ.	Max.	Unit	
SN74HC192							
HIGH-level input voltage	$V_{IH}$	$V_{CC}=2.0V$	1.5	1.2	-	V	
		$V_{CC}=4.5V$	3.15	2.4	-	V	
		$V_{CC}=6.0V$	4.2	3.2	-	V	
LOW-level input voltage	$V_{IL}$	$V_{CC}=2.0V$	-	0.8	0.5	V	
		$V_{CC}=4.5V$	-	2.1	1.35	V	
		$V_{CC}=6.0V$	-	2.8	1.8	V	
HIGH-level output voltage	$V_{OH}$	$V_I = V_{IH} \text{ or } V_{IL}$	$I_O=-20\mu A; V_{CC}=2.0V$	1.9	2.0	-	V
			$I_O=-20\mu A; V_{CC}=4.5V$	4.4	4.5	-	V
			$I_O=-20\mu A; V_{CC}=6.0V$	5.9	6.0	-	V
			$I_O=-4mA; V_{CC}=4.5V$	3.98	4.32	-	V
			$I_O=-5.2mA; V_{CC}=6.0V$	5.48	5.81	-	V
LOW-level output voltage	$V_{OL}$	$V_I = V_{IH} \text{ or } V_{IL}$	$I_O=20\mu A; V_{CC}=2.0V$	-	0	0.1	V
			$I_O=20\mu A; V_{CC}=4.5V$	-	0	0.1	V
			$I_O=20\mu A; V_{CC}=6.0V$	-	0	0.1	V
			$I_O=4mA; V_{CC}=4.5V$	-	0.15	0.26	V
			$I_O=5.2mA; V_{CC}=6.0V$	-	0.16	0.26	V





# 深圳市灵星芯微电子科技有限公司

Shenzhen Lingxing Microelectronics Technology Co., Ltd.

版次: B1

编号: SN74HC/HCT192-LX-A192

input leakage current	$I_I$	$V_I=V_{CC}$ or GND; $V_{CC}=6.0V$	-	-	$\pm 0.1$	$\mu A$	
supply current	$I_{CC}$	$V_I=V_{CC}$ or GND; $I_O=0A$ ; $V_{CC}=6.0V$	-	-	8.0	$\mu A$	
input capacitance	$C_I$	-	-	3.5	-	pF	
SN74HCT192							
HIGH-level input voltage	$V_{IH}$	$V_{CC}=4.5V$ to 5.5V	2.0	1.6	-	V	
LOW-level input voltage	$V_{IL}$	$V_{CC}=4.5V$ to 5.5V	-	1.2	0.8	V	
HIGH-level output voltage	$V_{OH}$	$V_I = V_{IH}$ or $V_{IL}$ ; $V_{CC}=4.5V$	$I_O=-20\mu A$	4.4	4.5	-	V
			$I_O=-4mA$	3.98	4.32	-	V
LOW-level output voltage	$V_{OL}$	$V_I = V_{IH}$ or $V_{IL}$ ; $V_{CC}=4.5V$	$I_O=20\mu A$	-	0	0.1	V
			$I_O=4mA$	-	0.15	0.26	V
input leakage current	$I_I$	$V_I=V_{CC}$ or GND; $V_{CC}=5.5V$	-	-	$\pm 0.1$	$\mu A$	
supply current	$I_{CC}$	$V_I=V_{CC}$ or GND; $I_O=0A$ ; $V_{CC}=5.5V$	-	-	8.0	$\mu A$	
additional supply current	$\Delta I_{CC}$	per input pin; $V_I=V_{CC}-2.1V$ ; other inputs at $V_{CC}$ or GND; $I_O=0A$ ; $V_{CC}=4.5V$ to 5.5V;	pin Dn	-	35	126	$\mu A$
			pins CPU, CPD	-	140	504	$\mu A$
			pin PL	-	65	234	$\mu A$
			pin MR	-	105	378	$\mu A$
input capacitance	$C_I$	-	-	3.5	-	pF	

### 3.3.2、DC Characteristics 2

( $T_{amb}=-40^{\circ}C$  to  $+85^{\circ}C$ , voltages are referenced to GND (ground=0V), unless otherwise specified.)

Parameter	Symbol	Conditions	Min.	Typ.	Max.	Unit	
SN74HC192							
HIGH-level input voltage	$V_{IH}$	$V_{CC}=2.0V$	1.5	-	-	V	
		$V_{CC}=4.5V$	3.15	-	-	V	
		$V_{CC}=6.0V$	4.2	-	-	V	
LOW-level input voltage	$V_{IL}$	$V_{CC}=2.0V$	-	-	0.5	V	
		$V_{CC}=4.5V$	-	-	1.35	V	
		$V_{CC}=6.0V$	-	-	1.8	V	
HIGH-level output voltage	$V_{OH}$	$V_I = V_{IH}$ or $V_{IL}$	$I_O=-20\mu A$ ; $V_{CC}=2.0V$	1.9	-	-	V
			$I_O=-20\mu A$ ; $V_{CC}=4.5V$	4.4	-	-	V
			$I_O=-20\mu A$ ; $V_{CC}=6.0V$	5.9	-	-	V
			$I_O=-4mA$ ; $V_{CC}=4.5V$	3.84	-	-	V
			$I_O=-5.2mA$ ; $V_{CC}=6.0V$	5.34	-	-	V
LOW-level output voltage	$V_{OL}$	$V_I = V_{IH}$ or $V_{IL}$	$I_O=20\mu A$ ; $V_{CC}=2.0V$	-	-	0.1	V
			$I_O=20\mu A$ ; $V_{CC}=4.5V$	-	-	0.1	V
			$I_O=20\mu A$ ; $V_{CC}=6.0V$	-	-	0.1	V
			$I_O=4mA$ ; $V_{CC}=4.5V$	-	-	0.33	V
			$I_O=5.2mA$ ; $V_{CC}=6.0V$	-	-	0.33	V



# 深圳市灵星芯微电子科技有限公司

Shenzhen Lingxing Microelectronics Technology Co., Ltd.

版次: B1

编号: SN74HC/HCT192-LX-A192

input leakage current	$I_I$	$V_I=V_{CC}$ or GND; $V_{CC}=6.0V$	-	-	$\pm 1.0$	$\mu A$	
supply current	$I_{CC}$	$V_I=V_{CC}$ or GND; $I_O=0A$ ; $V_{CC}=6.0V$	-	-	80	$\mu A$	
input capacitance	$C_I$	-	-	-	-	pF	
SN74HC192							
HIGH-level input voltage	$V_{IH}$	$V_{CC}=4.5V$ to 5.5V	2.0	-	-	V	
LOW-level input voltage	$V_{IL}$	$V_{CC}=4.5V$ to 5.5V	-	-	0.8	V	
HIGH-level output voltage	$V_{OH}$	$V_I = V_{IH}$ or $V_{IL}$ ; $V_{CC}=4.5V$	$I_O=-20\mu A$	4.4	-	-	V
			$I_O=-4mA$	3.84	-	-	V
LOW-level output voltage	$V_{OL}$	$V_I = V_{IH}$ or $V_{IL}$ ; $V_{CC}=4.5V$	$I_O=20\mu A$	-	-	0.1	V
			$I_O=4mA$	-	-	0.33	V
input leakage current	$I_I$	$V_I=V_{CC}$ or GND; $V_{CC}=5.5V$	-	-	$\pm 1.0$	$\mu A$	
supply current	$I_{CC}$	$V_I=V_{CC}$ or GND; $I_O=0A$ ; $V_{CC}=5.5V$	-	-	80	$\mu A$	
additional supply current	$\Delta I_{CC}$	per input pin; $V_I=V_{CC}-2.1V$ ; other inputs at $V_{CC}$ or GND; $I_O=0A$ ; $V_{CC}=4.5V$ to 5.5V;	pin Dn	-	-	157.5	$\mu A$
			pins CPU, CPD	-	-	630	$\mu A$
			pin PL	-	-	292.5	$\mu A$
			pin MR	-	-	472.5	$\mu A$
input capacitance	$C_I$	-	-	-	-	pF	

### 3.3.3 AC Characteristics 1

( $T_{amb}=25^{\circ}C$ , GND=0V,  $t_r=t_f=6ns$ ,  $C_L=50pF$ , unless otherwise specified.)

Parameter	Symbol	Conditions	Min.	Typ.	Max.	Unit	
SN74HC192							
propagation delay	$t_{pd}$	CPU, CPD to Qn; see Figure 7	$V_{CC}=2.0V$	-	66	215	ns
			$V_{CC}=4.5V$	-	23	43	ns
			$V_{CC}=5.0V$ ; $C_L=15pF$	-	24	-	ns
			$V_{CC}=6.0V$	-	19	37	ns
		CPU to TCU; see Figure 8	$V_{CC}=2.0V$	-	33	125	ns
			$V_{CC}=4.5V$	-	12	25	ns
			$V_{CC}=6.0V$	-	10	21	ns
		CPD to TCD; see Figure 8	$V_{CC}=2.0V$	-	39	125	ns
			$V_{CC}=4.5V$	-	14	25	ns
			$V_{CC}=6.0V$	-	11	21	ns
		PL to Qn; see Figure 9	$V_{CC}=2.0V$	-	69	215	ns
			$V_{CC}=4.5V$	-	25	43	ns
			$V_{CC}=6.0V$	-	20	37	ns
		MR to Qn; see Figure 10	$V_{CC}=2.0V$	-	63	200	ns
			$V_{CC}=4.5V$	-	23	40	ns
			$V_{CC}=6.0V$	-	18	34	ns



# 深圳市灵星芯微电子科技有限公司

Shenzhen Lingxing Microelectronics Technology Co., Ltd.

版次: B1

编号: SN74HC/HCT192-LX-A192

		Dn to Qn; see Figure 9	V <sub>CC</sub> =2.0V	-	91	275	ns
			V <sub>CC</sub> =4.5V	-	33	55	ns
			V <sub>CC</sub> =6.0V	-	26	47	ns
		PL to TCU, PL to TCD; see Figure 12	V <sub>CC</sub> =2.0V	-	102	315	ns
			V <sub>CC</sub> =4.5V	-	37	63	ns
			V <sub>CC</sub> =6.0V	-	30	54	ns
MR to TCU,	V <sub>CC</sub> =2.0V	-	96	285	ns		
	V <sub>CC</sub> =4.5V	-	35	57	ns		
		MR to TCD; see Figure 12	V <sub>CC</sub> =6.0V	-	28	48	ns
			Dn to TCU, Dn to TCD; see Figure 12	V <sub>CC</sub> =2.0V	-	83	290
		V <sub>CC</sub> =4.5V	-	30	58	ns	
		V <sub>CC</sub> =6.0V	-	24	49	ns	
transition time	t <sub>t</sub>	see Figure 10	V <sub>CC</sub> =2.0V	-	19	75	ns
			V <sub>CC</sub> =4.5V	-	7	15	ns
			V <sub>CC</sub> =6.0V	-	6	13	ns
pulse width	t <sub>w</sub>	up clock pulse width HIGH or LOW; see Figure 7	V <sub>CC</sub> =2.0V	120	39	-	ns
			V <sub>CC</sub> =4.5V	24	14	-	ns
			V <sub>CC</sub> =6.0V	20	11	-	ns
		down clock pulse width HIGH or LOW; see Figure 7	V <sub>CC</sub> =2.0V	140	50	-	ns
			V <sub>CC</sub> =4.5V	28	18	-	ns
			V <sub>CC</sub> =6.0V	24	14	-	ns
		master reset pulse width HIGH; see Figure 10	V <sub>CC</sub> =2.0V	80	22	-	ns
			V <sub>CC</sub> =4.5V	16	8	-	ns
			V <sub>CC</sub> =6.0V	14	6	-	ns
		parallel load pulse width LOW; see Figure 9	V <sub>CC</sub> =2.0V	80	22	-	ns
V <sub>CC</sub> =4.5V	16		8	-	ns		
V <sub>CC</sub> =6.0V	14		6	-	ns		
recovery time	t <sub>rec</sub>	PL to CPU, CPD; see Figure 9	V <sub>CC</sub> =2.0V	50	3	-	ns
			V <sub>CC</sub> =4.5V	10	1	-	ns
			V <sub>CC</sub> =6.0V	9	1	-	ns
		MR to CPU, CPD; see Figure 10	V <sub>CC</sub> =2.0V	50	0	-	ns
			V <sub>CC</sub> =4.5V	10	0	-	ns
			V <sub>CC</sub> =6.0V	9	0	-	ns
set-up time	t <sub>su</sub>	Dn to PL; see Figure 11; note: CPU=CPD=HIGH	V <sub>CC</sub> =2.0V	80	22	-	ns
			V <sub>CC</sub> =4.5V	16	8	-	ns
			V <sub>CC</sub> =6.0V	14	6	-	ns
hold time	t <sub>h</sub>	Dn to PL; see Figure 11	V <sub>CC</sub> =2.0V	0	-14	-	ns
			V <sub>CC</sub> =4.5V	0	-5	-	ns
			V <sub>CC</sub> =6.0V	0	-4	-	ns
		CPU to CPD, CPD to CPU;	V <sub>CC</sub> =2.0V	80	19	-	ns
			V <sub>CC</sub> =4.5V	16	7	-	ns



# 深圳市灵星芯微电子科技有限公司

Shenzhen Lingxing Microelectronics Technology Co., Ltd.

版次: B1

编号: SN74HC/HCT192-LX-A192

		see Figure 13	$V_{CC}=6.0V$	14	6	-	ns
maximum frequency	$f_{max}$	CPU, CPD; see Figure 7	$V_{CC}=2.0V$	4.0	12	-	MHz
			$V_{CC}=4.5V$	20	36	-	MHz
			$V_{CC}=5.0V; C_L=15pF$	-	40	-	MHz
			$V_{CC}=6.0V$	24	43	-	MHz
power dissipation capacitance	$C_{PD}$	$V_I=GND$ to $V_{CC}$	-	24	-	pF	
SN74HCT192							
propagation delay	$t_{pd}$	CPU, CPD to $Q_n$ ; see Figure 7	$V_{CC}=4.5V$	-	23	43	ns
			$V_{CC}=5.0V; C_L=15pF$	-	20	-	ns
		CPU to $\overline{TCU}$ ; see Figure 8	$V_{CC}=4.5V$	-	16	30	ns
		CPD to $\overline{TCD}$ ; see Figure 8	$V_{CC}=4.5V$	-	17	30	ns
		$\overline{PL}$ to $Q_n$ ; see Figure 9	$V_{CC}=4.5V$	-	28	46	ns
		MR to $Q_n$ ; see Figure 10	$V_{CC}=4.5V$	-	24	40	ns
		Dn to $Q_n$ ; see Figure 9	$V_{CC}=4.5V$	-	36	62	ns
		$\overline{PL}$ to $\overline{TCU}$ , $\overline{PL}$ to $\overline{TCD}$ ; see Figure 12	$V_{CC}=4.5V$	-	36	64	ns
		MR to $\overline{TCU}$ , MR to $\overline{TCD}$ ; see Figure 12	$V_{CC}=4.5V$	-	36	64	ns
		Dn to $\overline{TCU}$ , Dn to $\overline{TCD}$ ; see Figure 12	$V_{CC}=4.5V$	-	33	58	ns
transition time	$t_t$	see Figure 10; $V_{CC}=4.5V$		-	7	15	ns
pulse width	$t_w$	$V_{CC}=4.5V$	up, down clock pulse width HIGH or LOW; see Figure 7	25	14	-	ns
			master reset pulse width HIGH; see Figure 10	16	6	-	ns
			parallel load pulse width LOW; see Figure 9	20	10	-	ns
recovery time	$t_{rec}$	$V_{CC}=4.5V$	$\overline{PL}$ to CPU, CPD; see Figure 9	10	1	-	ns
			MR to CPU, CPD; see Figure 10	10	2	-	ns
set-up time	$t_{su}$	Dn to $\overline{PL}$ ; see Figure 11; note: CPU = CPD = HIGH; $V_{CC}=4.5V$		16	8	-	ns
			Dn to $\overline{PL}$ ; see Figure 11	0	-6	-	ns



# 深圳市灵星芯微电子科技有限公司

Shenzhen Lingxing Microelectronics Technology Co., Ltd.

版次: B1

编号: SN74HC/HCT192-LX-A192

hold time	$t_h$	$V_{CC}=4.5V$	CPU to CPD, CPD to CPU; see Figure 13	20	9	-	ns
maximum frequency	$f_{max}$	CPU, CPD; see Figure 7;	$V_{CC}=4.5V$	20	41	-	MHz
			$V_{CC}=5.0V; C_L=15pF$	-	45	-	MHz
power dissipation capacitance	$C_{PD}$	$V_I=GND$ to $V_{CC}-1.5V$		-	28	-	pF

Note:

[1]  $t_{pd}$  is the same as  $t_{PLH}$  and  $t_{PHL}$ .

[2]  $t_i$  is the same as  $t_{THL}$  and  $t_{TLH}$ .

[3]  $C_{PD}$  is used to determine the dynamic power dissipation ( $P_D$  in uW).

$P_D=C_{PD} \times V_{CC}^2 \times f_i + \sum(C_L \times V_{CC}^2 \times f_o)$  where:

$f_i$ =input frequency in MHz;

$f_o$ =output frequency in MHz;

$C_L$ =output load capacitance in pF;

$V_{CC}$ =supply voltage in V;

$\sum(C_L \times V_{CC}^2 \times f_o)$ =sum of outputs.

### 3.3.4 AC Characteristics 2

( $T_{amb}=-40^\circ C$  to  $+85^\circ C$ ,  $GND=0V$ ,  $t_r=t_f=6ns$ ,  $C_L=50pF$ , unless otherwise specified.)

Parameter	Symbol	Conditions	Min.	Typ.	Max.	Unit	
SN74HC192							
propagation delay	$t_{pd}$	CPU, CPD to Qn; see Figure 7	$V_{CC}=2.0V$	-	-	270	ns
			$V_{CC}=4.5V$	-	-	54	ns
			$V_{CC}=5.0V; C_L=15pF$	-	-	-	ns
			$V_{CC}=6.0V$	-	-	46	ns
		CPU to TCU; see Figure 8	$V_{CC}=2.0V$	-	-	155	ns
			$V_{CC}=4.5V$	-	-	31	ns
			$V_{CC}=6.0V$	-	-	26	ns
		CPD to TCD; see Figure 8	$V_{CC}=2.0V$	-	-	155	ns
			$V_{CC}=4.5V$	-	-	31	ns
			$V_{CC}=6.0V$	-	-	26	ns
		PL to Qn; see Figure 9	$V_{CC}=2.0V$	-	-	270	ns
			$V_{CC}=4.5V$	-	-	54	ns
			$V_{CC}=6.0V$	-	-	46	ns
		MR to Qn; see Figure 10	$V_{CC}=2.0V$	-	-	250	ns
			$V_{CC}=4.5V$	-	-	50	ns
			$V_{CC}=6.0V$	-	-	43	ns
		Dn to Qn; see Figure 9	$V_{CC}=2.0V$	-	-	345	ns
			$V_{CC}=4.5V$	-	-	69	ns
			$V_{CC}=6.0V$	-	-	59	ns
		PL to TCU,	$V_{CC}=2.0V$	-	-	395	ns
$V_{CC}=4.5V$	-		-	79	ns		



# 深圳市灵星芯微电子科技有限公司

Shenzhen Lingxing Microelectronics Technology Co., Ltd.

版次: B1

编号: SN74HC/HCT192-LX-A192

		PL to TCD; see Figure 12	V <sub>CC</sub> =6.0V	-	-	67	ns
		MR to TCU, MR to TCD; see Figure 12	V <sub>CC</sub> =2.0V	-	-	355	ns
			V <sub>CC</sub> =4.5V	-	-	71	ns
			V <sub>CC</sub> =6.0V	-	-	60	ns
		Dn to TCU, Dn to TCD; see Figure 12	V <sub>CC</sub> =2.0V	-	-	365	ns
			V <sub>CC</sub> =4.5V	-	-	73	ns
			V <sub>CC</sub> =6.0V	-	-	62	ns
transition time	t <sub>t</sub>	see Figure 10	V <sub>CC</sub> =2.0V	-	-	95	ns
			V <sub>CC</sub> =4.5V	-	-	19	ns
			V <sub>CC</sub> =6.0V	-	-	16	ns
pulse width	t <sub>w</sub>	up clock pulse width HIGH or LOW; see Figure 7	V <sub>CC</sub> =2.0V	150	-	-	ns
			V <sub>CC</sub> =4.5V	30	-	-	ns
			V <sub>CC</sub> =6.0V	26	-	-	ns
		down clock pulse width HIGH or LOW;	V <sub>CC</sub> =2.0V	175	-	-	ns
			V <sub>CC</sub> =4.5V	35	-	-	ns
			V <sub>CC</sub> =6.0V	30	-	-	ns
		see Figure 7					
		master reset pulse width HIGH; see Figure 10	V <sub>CC</sub> =2.0V	100	-	-	ns
			V <sub>CC</sub> =4.5V	20	-	-	ns
			V <sub>CC</sub> =6.0V	17	-	-	ns
		parallel load pulse width LOW; see Figure 9	V <sub>CC</sub> =2.0V	100	-	-	ns
V <sub>CC</sub> =4.5V	20		-	-	ns		
V <sub>CC</sub> =6.0V	17		-	-	ns		
recovery time	t <sub>rec</sub>	PL to CPU, CPD; see Figure 9	V <sub>CC</sub> =2.0V	65	-	-	ns
			V <sub>CC</sub> =4.5V	13	-	-	ns
			V <sub>CC</sub> =6.0V	11	-	-	ns
		MR to CPU, CPD; see Figure 10	V <sub>CC</sub> =2.0V	65	-	-	ns
			V <sub>CC</sub> =4.5V	13	-	-	ns
			V <sub>CC</sub> =6.0V	11	-	-	ns
set-up time	t <sub>su</sub>	Dn to PL; see Figure 11; note: CPU=CPD=HIGH	V <sub>CC</sub> =2.0V	100	-	-	ns
			V <sub>CC</sub> =4.5V	20	-	-	ns
			V <sub>CC</sub> =6.0V	17	-	-	ns
hold time	t <sub>h</sub>	Dn to PL; see Figure 11	V <sub>CC</sub> =2.0V	0	-	-	ns
			V <sub>CC</sub> =4.5V	0	-	-	ns
			V <sub>CC</sub> =6.0V	0	-	-	ns
		CPU to CPD, CPD to CPU; see Figure 13	V <sub>CC</sub> =2.0V	100	-	-	ns
			V <sub>CC</sub> =4.5V	20	-	-	ns
			V <sub>CC</sub> =6.0V	17	-	-	ns
maximum frequency	f <sub>max</sub>	CPU, CPD; see Figure 7	V <sub>CC</sub> =2.0V	3.2	-	-	MHz
			V <sub>CC</sub> =4.5V	16	-	-	MHz
			V <sub>CC</sub> =5.0V; C <sub>L</sub> =15pF	-	-	-	MHz
			V <sub>CC</sub> =6.0V	19	-	-	MHz



# 深圳市灵星芯微电子科技有限公司

Shenzhen Lingxing Microelectronics Technology Co., Ltd.

版次: B1

编号: SN74HC/HCT192-LX-A192

power dissipation capacitance	$C_{PD}$	$V_I=GND$ to $V_{CC}$	-	-	-	pF	
SN74HCT192							
propagation delay	$t_{pd}$	CPU, CPD to Qn; see Figure 7	$V_{CC}=4.5V$	-	-	54	ns
			$V_{CC}=5.0V; C_L=15pF$	-	-	-	ns
		CPU to TCU; see Figure 8	$V_{CC}=4.5V$	-	-	38	ns
		CPD to TCD; see Figure 8	$V_{CC}=4.5V$	-	-	38	ns
		PL to Qn; see Figure 9	$V_{CC}=4.5V$	-	-	58	ns
		MR to Qn; see Figure 10	$V_{CC}=4.5V$	-	-	50	ns
		Dn to Qn; see Figure 9	$V_{CC}=4.5V$	-	-	78	ns
		PL to TCU, PL to TCD; see Figure 12	$V_{CC}=4.5V$	-	-	80	ns
		MR to TCU, MR to TCD; see Figure 12	$V_{CC}=4.5V$	-	-	80	ns
		Dn to TCU, Dn to TCD; see Figure 12	$V_{CC}=4.5V$	-	-	73	ns
transition time	$t_t$	see Figure 10; $V_{CC}=4.5V$		-	-	19	ns
pulse width	$t_w$	$V_{CC}=4.5V$	up, down clock pulse width HIGH or LOW; see Figure 7	31	-	-	ns
			master reset pulse width HIGH; see Figure 10	20	-	-	ns
			parallel load pulse width LOW; see Figure 9	25	-	-	ns
recovery time	$t_{rec}$	$V_{CC}=4.5V$	PL to CPU, CPD; see Figure 9	13	-	-	ns
			MR to CPU, CPD; see Figure 10	13	-	-	ns
set-up time	$t_{su}$	Dn to PL; see Figure 11; note: CPU = CPD = HIGH; $V_{CC}=4.5V$		20	-	-	ns
hold time	$t_h$	$V_{CC}=4.5V$	Dn to PL; see Figure 11	0	-	-	ns
			CPU to CPD, CPD to CPU; see Figure 13	25	-	-	ns
maximum frequency	$f_{max}$	CPU, CPD; see Figure 7;	$V_{CC}=4.5V$	16	-	-	MHz
			$V_{CC}=5.0V; C_L=15pF$	-	-	-	MHz



power dissipation capacitance	$C_{PD}$	$V_I=GND$ to $V_{CC}-1.5V$	-	-	-	pF
-------------------------------	----------	----------------------------	---	---	---	----

Note:

[1]  $t_{pd}$  is the same as  $t_{PLH}$  and  $t_{PHL}$ .

[2]  $t_t$  is the same as  $t_{THL}$  and  $t_{TLH}$ .

[3]  $C_{PD}$  is used to determine the dynamic power dissipation ( $P_D$  in uW).

$$P_D = C_{PD} \times V_{CC}^2 \times f_i + \sum (C_L \times V_{CC}^2 \times f_o) \text{ where:}$$

$f_i$ =input frequency in MHz;

$f_o$ =output frequency in MHz;

$C_L$ =output load capacitance in pF;

$V_{CC}$ =supply voltage in V;

$\sum (C_L \times V_{CC}^2 \times f_o)$ =sum of outputs.

## 4、 Testing Circuit

### 4.1 、 AC Testing Circuit

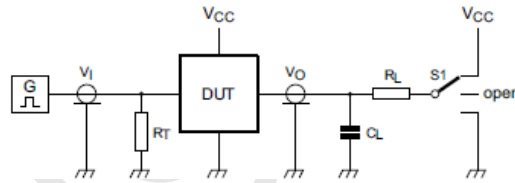
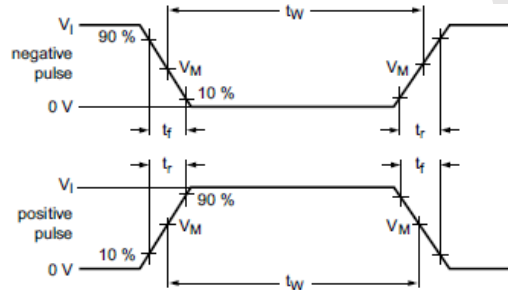

Figure 6. Test circuit for measuring switching times

Definitions for test circuit:

$R_L$ =Load resistance.

$C_L$ =Load capacitance including jig and probe capacitance.

$R_T$ =Termination resistance should be equal to the output impedance  $Z_o$  of the pulse generator.

$S1$ =Test selection switch.

### 4.2 、 AC Testing Waveforms

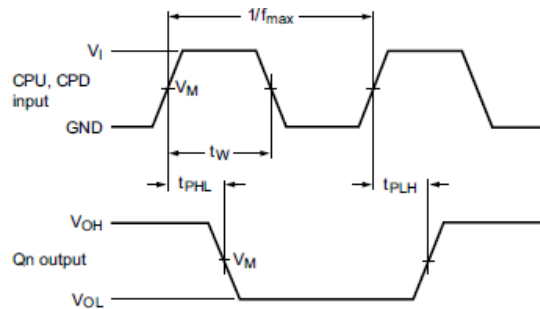





Figure 7. The clock (CPU, CPD) to output (Qn) propagation delays, the clock pulse width, and the maximum clock pulse frequency

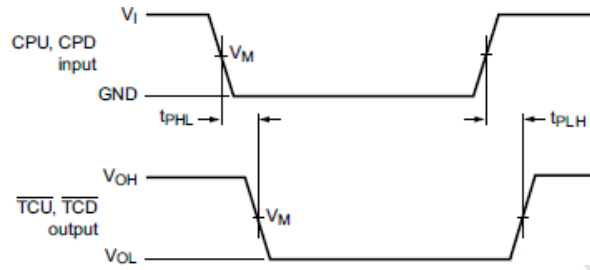

Figure 8. The clock (CPU, CPD) to terminal count output (TCU, TCD) propagation delays

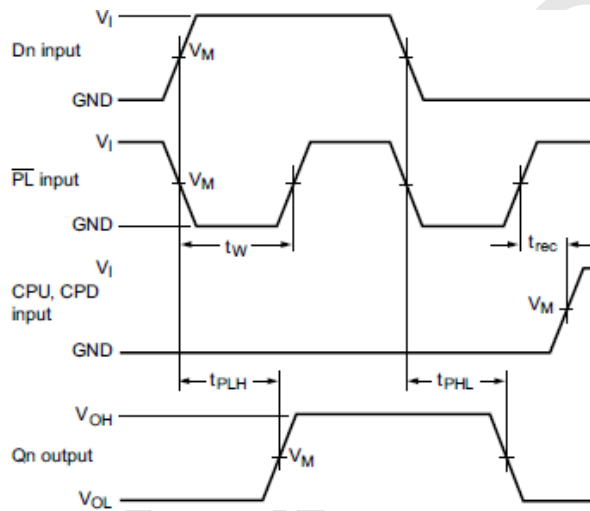

Figure 9. The parallel load input (PL) and data (Dn) to Qn output propagation delays and PL removal time to clock input (CPU, CPD)

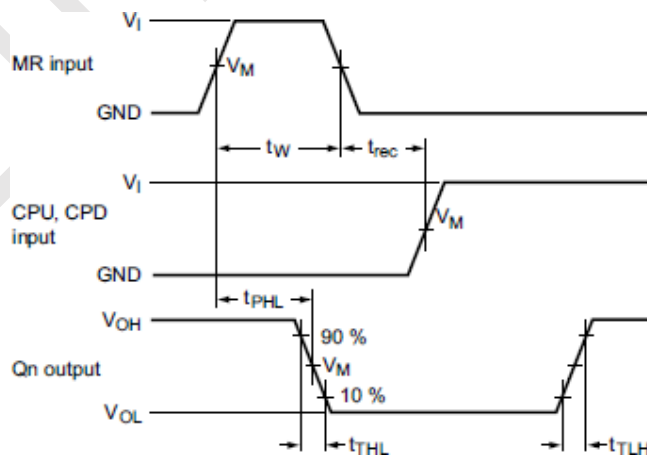

Figure 10. The master reset input (MR) pulse width, MR to Qn propagation delays, MR to CPU, CPD



removal time and output transition times

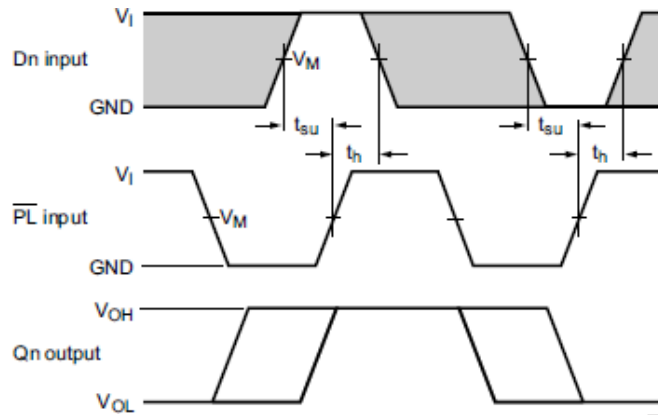

Figure 11. The data input (Dn) to parallel load input (PL) set-up and hold times

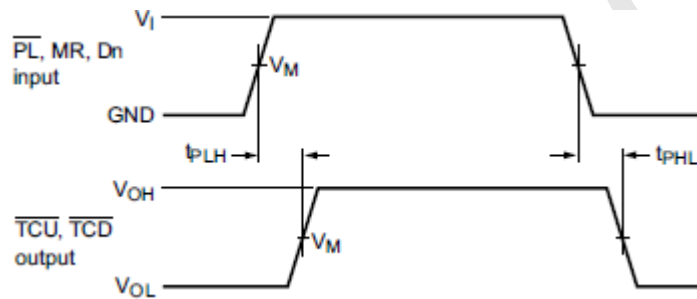

Figure 12. The data input (Dn), parallel load input (PL) and the master reset input (MR) to the terminal count outputs (TCU, TCD) propagation delays

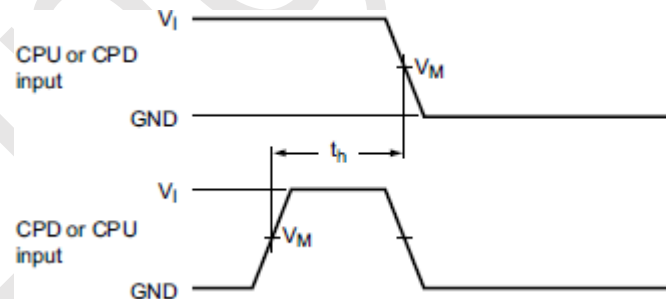

Figure 13. The CPU to CPD or CPD to CPU hold times

#### 4.3 Measurement Points

Type	Input		Output
	V <sub>I</sub>	V <sub>M</sub>	V <sub>M</sub>
SN74HC192	GND to V <sub>CC</sub>	0.5×V <sub>CC</sub>	0.5×V <sub>CC</sub>
SN74HCT192	GND to 3V	1.3V	1.3V



## 4.4、Test Data

Type	Input		Load		S1 position
	V <sub>I</sub>	t <sub>r</sub> , t <sub>f</sub>	C <sub>L</sub>	R <sub>L</sub>	t <sub>PHL</sub> , t <sub>PLH</sub>
SN74HC192	V <sub>CC</sub>	6ns	15pF, 50pF	1kΩ	open
SN74HCT192	3V	6ns	15pF, 50pF	1kΩ	open

## 5、Package Information

### 5.1、DIP16

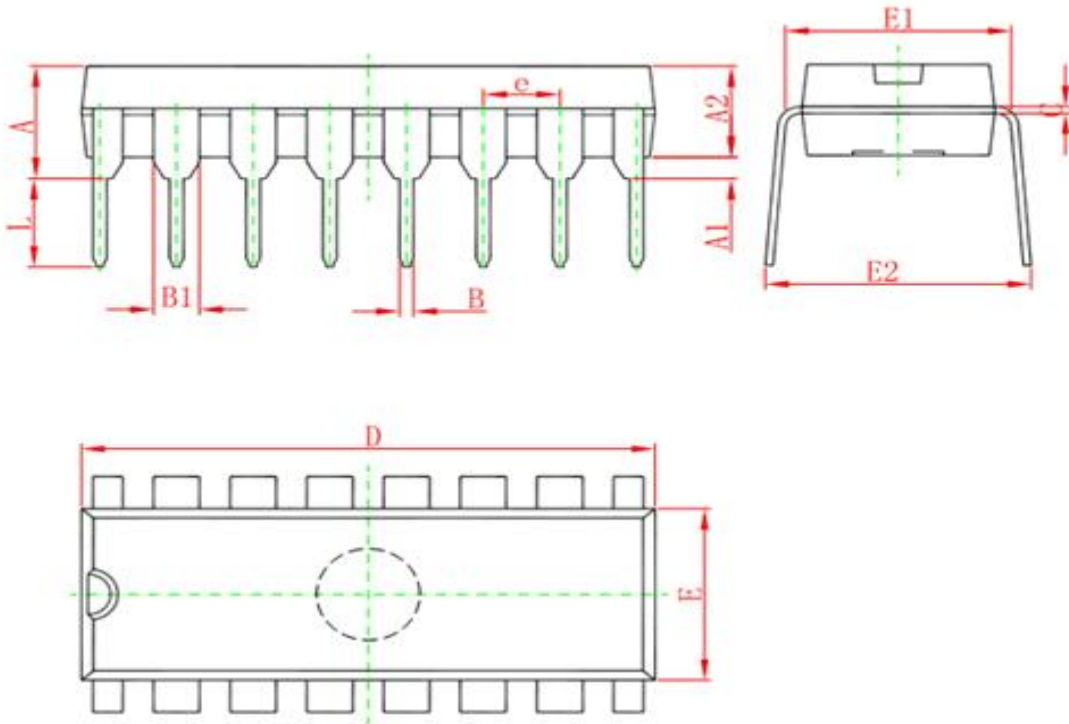

Symbol	Dimensions In Millimeters		Dimensions In Inches	
	Min	Max	Min	Max
A	3.710	4.310	0.146	0.170
A1	0.510		0.020	
A2	3.200	3.600	0.126	0.142
B	0.380	0.570	0.015	0.022
B1	1.524 (BSC)		0.060 (BSC)	
C	0.204	0.360	0.008	0.014
D	18.800	19.200	0.740	0.756
E	6.200	6.600	0.244	0.260
E1	7.320	7.920	0.288	0.312
e	2.540 (BSC)		0.100 (BSC)	
L	3.000	3.600	0.118	0.142
E2	8.400	9.000	0.331	0.354



## 5.2、SOP16

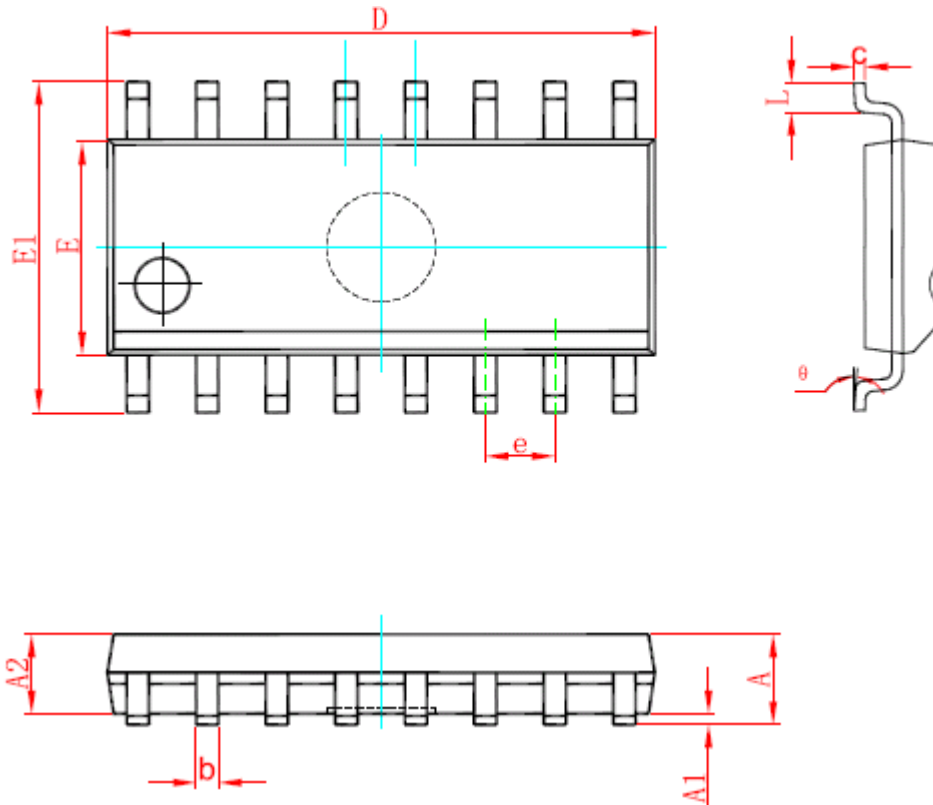

Symbol	Dimensions In Millimeters		Dimensions In Inches	
	Min	Max	Min	Max
A	1.350	1.750	0.053	0.069
A1	0.100	0.250	0.004	0.010
A2	1.350	1.550	0.053	0.061
b	0.330	0.510	0.013	0.020
c	0.170	0.250	0.007	0.010
D	9.800	10.200	0.386	0.402
E	3.800	4.000	0.150	0.157
E1	5.800	6.200	0.228	0.244
e	1.270 (BSC)		0.050 (BSC)	
L	0.400	1.270	0.016	0.050
θ	0°	8°	0°	8°



5.3、TSSOP16

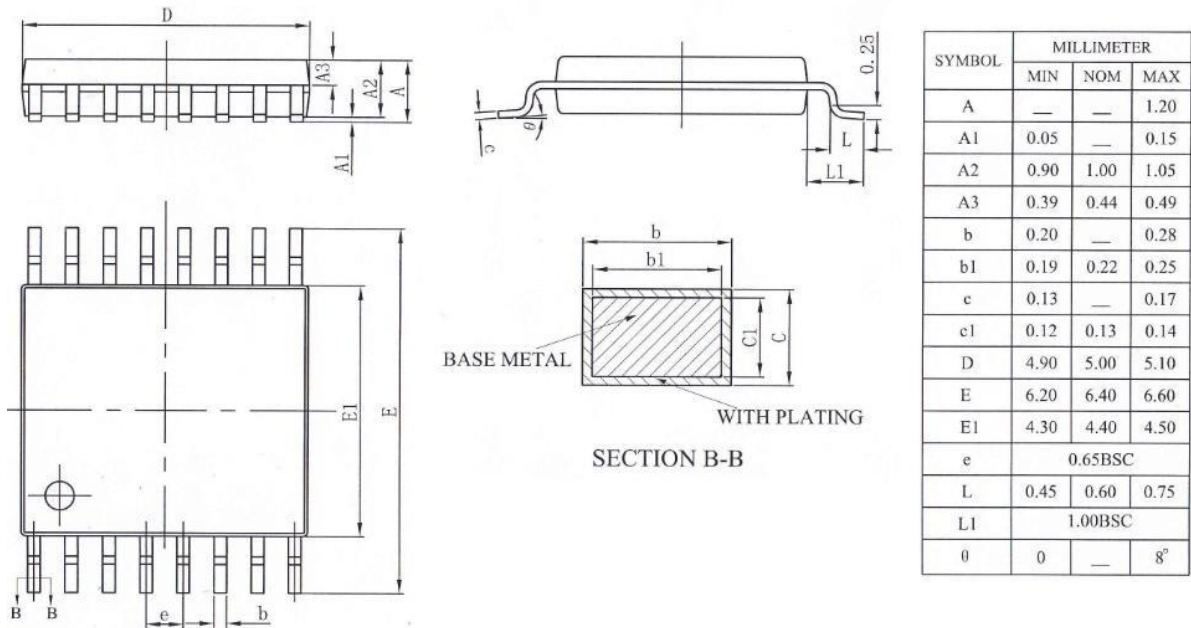



## 6、 Statements And Notes

### 6.1 、 The name and content of Hazardous substances or Elements in the product

Part name	Hazardous substances or Elements									
	Lead and lead compounds	Mercury and mercury compounds	Cadmium and cadmium compounds	Hexavalent chromium compounds	Polybrominated biphenyls	Polybrominated biphenyl ethers	Dibutyl phthalate	Butylbenzyl phthalate	Di-2-ethylhexyl phthalate	Diisobutyl phthalate
Lead frame	○	○	○	○	○	○	○	○	○	○
Plastic resin	○	○	○	○	○	○	○	○	○	○
Chip	○	○	○	○	○	○	○	○	○	○
The lead	○	○	○	○	○	○	○	○	○	○
Plastic sheet installed	○	○	○	○	○	○	○	○	○	○
explanation	○: Indicates that the content of hazardous substances or elements in the detection limit of the following the SJ/T11363-2006 standard. ×: Indicates that the content of hazardous substances or elements exceeding the SJ/T11363-2006 Standard limit requirements.									

### 6.2 、 Notion

Recommended carefully reading this information before the use of this product;

The information in this document are subject to change without notice;

This information is using to the reference only, the company is not responsible for any loss;

The company is not responsible for the any infringement of the third party patents or other rights of the responsibility.