



**SOT-23-6L Plastic-Encapsulate MOSFETS**

**CJL6602** P-channel and N-channel Complementary MOSFETS

P-channel

$V_{(BR)DSS}$	$R_{DS(on)MAX}$	$I_D$
-30V	135mΩ@-10V	-2.3A
	185mΩ@-4.5V	
	265mΩ@-2.5V	

N-channel

$V_{(BR)DSS}$	$R_{DS(on)MAX}$	$I_D$
30V	60mΩ@10V	3.4A
	75mΩ@4.5V	
	115mΩ@2.5V	

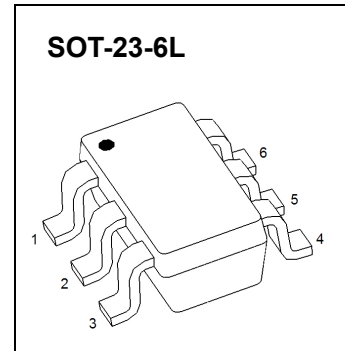

**GENERAL DESCRIPTION**

The CJL6602 uses advanced trench technology to provide excellent  $R_{DS(on)}$  and low gate charge. The complementary MOSFETS form a high-speed power inverter and suitable for a multitude of applications.

**MARKING**

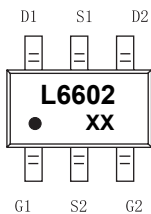

L6602=Device code  
 Solid point=Pin1 positioning point  
 XX=Date Code

**Equivalent Circuit**

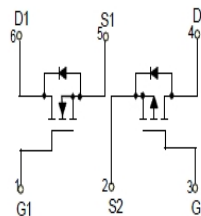

**Maximum Ratings ( $T_A=25^\circ\text{C}$  unless otherwise noted)**

Parameter	Symbol	Value		Unit
		N-channel	P-channel	
Drain-Source Voltage	$V_{DS}$	30	-30	V
Gate-Source Voltage	$V_{GS}$	$\pm 12$	$\pm 12$	V
Continuous Drain Current <sup>(1)</sup>	$I_D$	3.4	-2.3	A
Pulsed Drain Current <sup>(2)</sup>	$I_{DM}$	30	-30	A
Power Dissipation	$P_D$	0.35	0.35	W
Thermal Resistance from Junction to Ambient <sup>(1)</sup>	$R_{\theta JA}$	357	357	$^\circ\text{C}/\text{W}$
Operation Junction and Storage Temperature Range	$T_J, T_{stg}$	-55~+150	-55~+150	$^\circ\text{C}$

1. The value of  $R_{\theta JA}$  is measured with the device mounted on 1in<sup>2</sup> FR-4 board with 2oz. Copper, in a still air environment with  $T_A=25^\circ\text{C}$ . The value in any given application depends on the user's specific board design. The current ratings is based on  $t \leq 10\text{s}$  thermal resistance rating.

2. Repetitive rating, pulse with limited by junction temperature.

# MOSFET ELECTRICAL CHARACTERISTICS

## N-channel MOSFET Electrical Characteristics ( $T_A=25^\circ\text{C}$ unless otherwise noted)

Parameter	Symbol	Test Condition	Min	Typ	Max	Unit
<b>Static characteristics</b>						
Drain-source breakdown voltage	$V_{(BR)DSS}$	$V_{GS} = 0V, I_D = 250\mu A$	30			V
Zero gate voltage drain current	$I_{DSS}$	$V_{DS} = 24V, V_{GS} = 0V$			1	$\mu A$
Gate-source leakage current (note1)	$I_{GSS}$	$V_{GS} = \pm 12V, V_{DS} = 0V$			$\pm 100$	nA
Drain-source on-resistance (note1)	$R_{DS(on)}$	$V_{GS} = 10V, I_D = 3A$		45	60	$m\Omega$
		$V_{GS} = 4.5V, I_D = 3A$		50	75	$m\Omega$
		$V_{GS} = 2.5V, I_D = 2A$		60	115	$m\Omega$
Forward tranconductance (note1)	$g_{FS}$	$V_{DS} = 5V, I_D = 3A$	5			S
Gate threshold voltage	$V_{GS(th)}$	$V_{DS} = V_{GS}, I_D = 250\mu A$	0.6		1.4	V
Diode forward voltage (note1)	$V_{SD}$	$I_S = 1A, V_{GS} = 0V$			1	V
<b>Dynamic characteristics (note2)</b>						
Input capacitance	$C_{iss}$	$V_{GS} = 0V, V_{DS} = 15V, f = 1MHz$		390		pF
Output capacitance	$C_{oss}$			54.5		pF
Reverse transfer capacitance	$C_{rss}$			41		pF
Gate resistance	$R_g$	$V_{GS} = 0V, V_{DS} = 0V, f = 1MHz$		3		$\Omega$
<b>Switching Characteristics (note2)</b>						
Turn-on delay time	$t_{d(on)}$	$V_{GS} = 10V, V_{DS} = 15V,$ $R_L = 5\Omega, R_{GEN} = 6\Omega$		4		ns
Turn-on rise time	$t_r$			2		ns
Turn-off delay time	$t_{d(off)}$			22		ns
Turn-off fall time	$t_f$			3		ns

## P-channel MOSFET Electrical Characteristics ( $T_A=25^\circ\text{C}$ unless otherwise noted)

Parameter	Symbol	Test Condition	Min	Typ	Max	Unit
<b>Static characteristics</b>						
Drain-source breakdown voltage	$V_{(BR)DSS}$	$V_{GS} = 0V, I_D = -250\mu A$	-30			V
Zero gate voltage drain current	$I_{DSS}$	$V_{DS} = -24V, V_{GS} = 0V$			-1	$\mu A$
Gate-source leakage current	$I_{GSS}$	$V_{GS} = \pm 12V, V_{DS} = 0V$			$\pm 100$	nA
Drain-source on-resistance (note1)	$R_{DS(on)}$	$V_{GS} = -10V, I_D = -2.3A$		75	135	$m\Omega$
		$V_{GS} = -4.5V, I_D = -2A$		95	185	$m\Omega$
		$V_{GS} = -2.5V, I_D = -1A$		140	265	$m\Omega$
Forward tranconductance (note1)	$g_{FS}$	$V_{DS} = -5V, I_D = -2.3A$	4.5			S
Gate threshold voltage	$V_{GS(th)}$	$V_{DS} = V_{GS}, I_D = -250\mu A$	-0.6		-1.4	V
Diode forward voltage (note1)	$V_{DS}$	$I_S = -1A, V_{GS} = 0V$			-1	V
<b>Dynamic characteristics (note2)</b>						
Input capacitance	$C_{iss}$	$V_{GS} = 0V, V_{DS} = -15V, f = 1MHz$		409		pF
Output capacitance	$C_{oss}$			55		pF
Reverse transfer capacitance	$C_{rss}$			42		pF
Gate resistance	$R_g$	$V_{GS} = 0V, V_{DS} = 0V, f = 1MHz$		12		$\Omega$
<b>Switching Characteristics (note2)</b>						
Turn-on delay time	$t_{d(on)}$	$V_{GS} = -10V, V_{DS} = -15V,$ $R_L = 6\Omega, R_{GEN} = 6\Omega$		13		ns
Turn-on rise time	$t_r$			10		ns
Turn-off delay time	$t_{d(off)}$			28		ns
Turn-off fall time	$t_f$			13		ns

- Notes :**
1. Pulse Test : Pulse width  $\leq 300\mu s$ , duty cycle  $\leq 0.5\%$ .
  2. Guaranteed by design, not subject to production testing.

# Typical Characteristics

## N-Channel-MOS

Output Characteristics

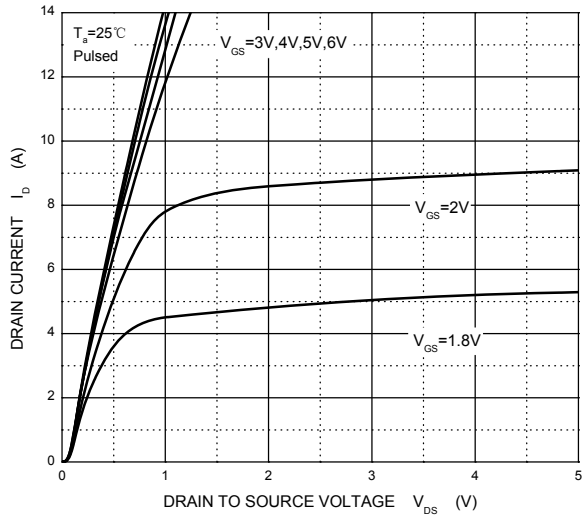

Transfer Characteristics

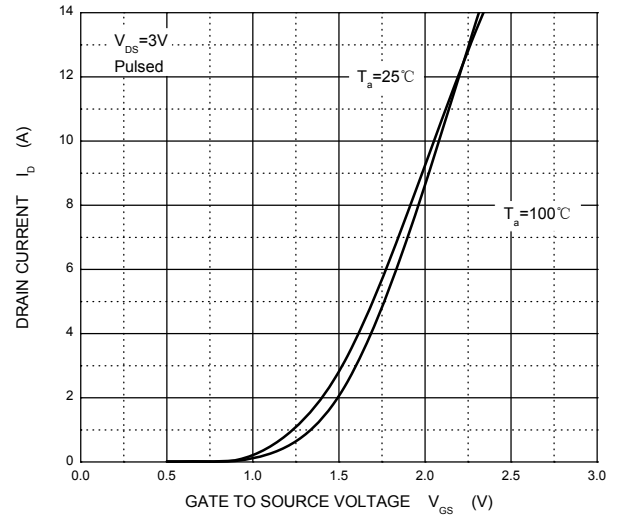

$R_{DS(ON)}$  —  $I_D$

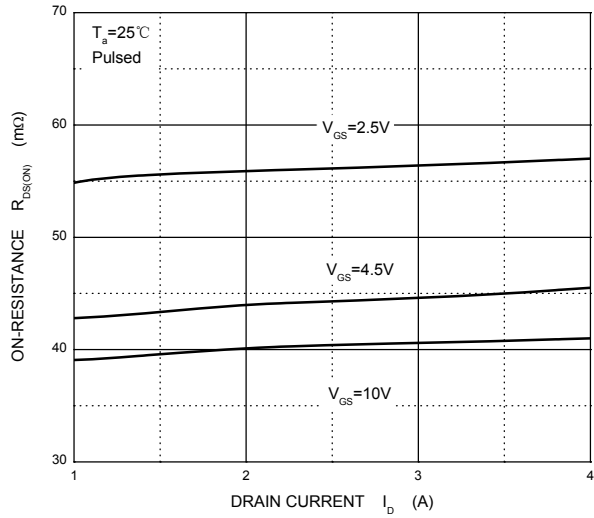

$R_{DS(ON)}$  —  $V_{GS}$

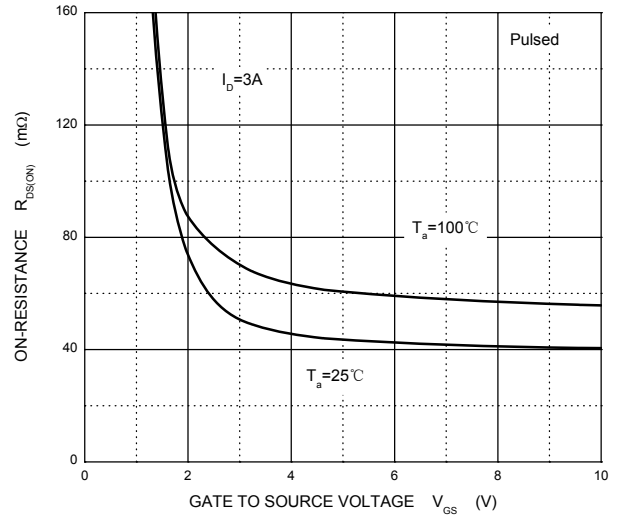

$I_S$  —  $V_{SD}$

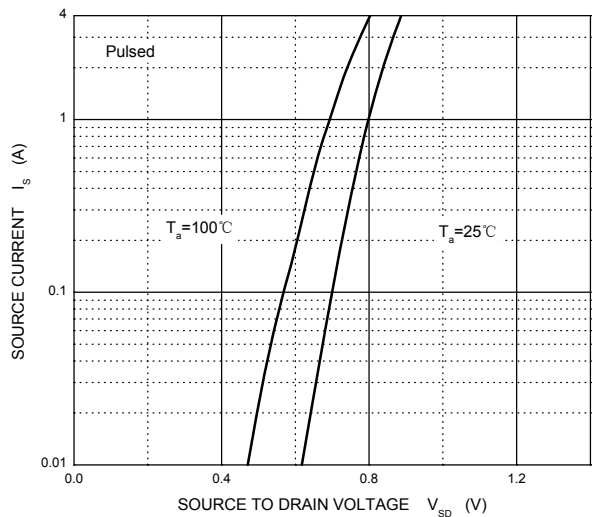

Threshold Voltage

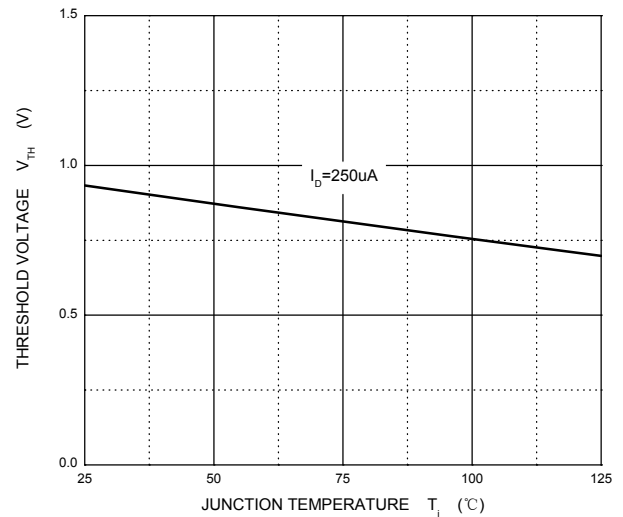

# Typical Characteristics

P-Channel-MOS

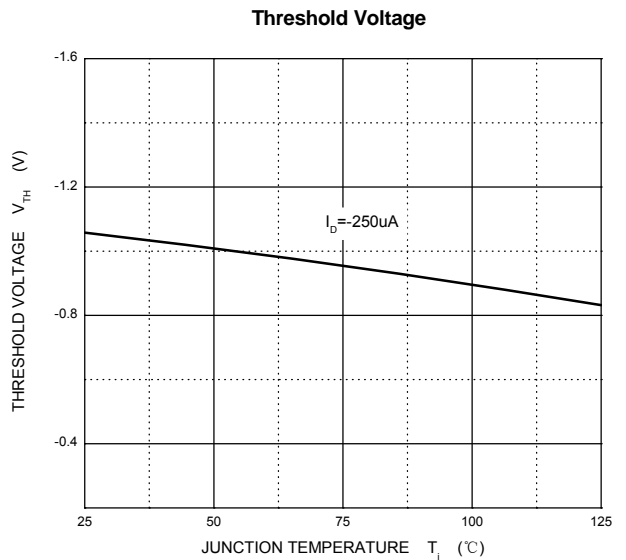
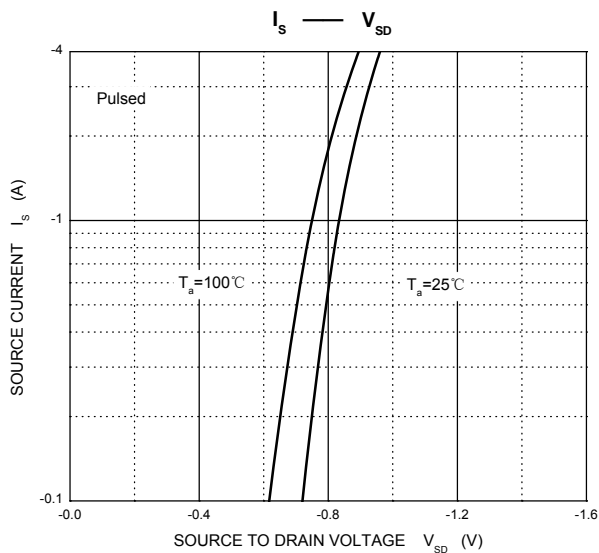
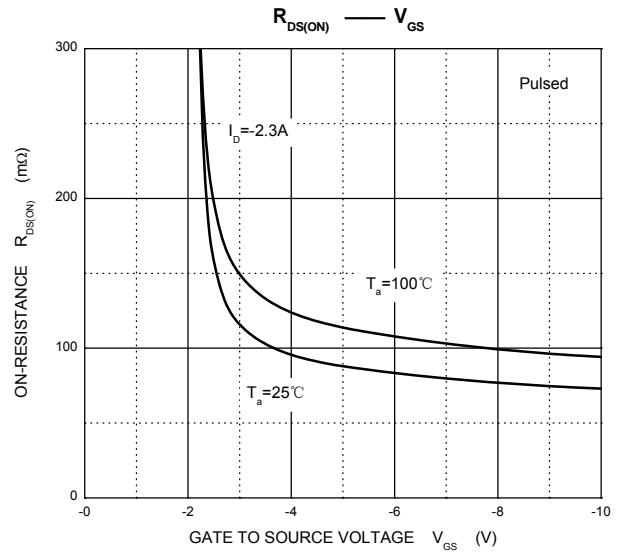
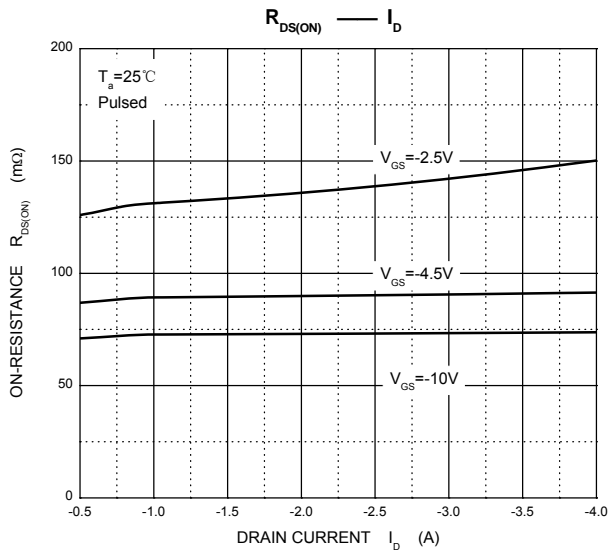
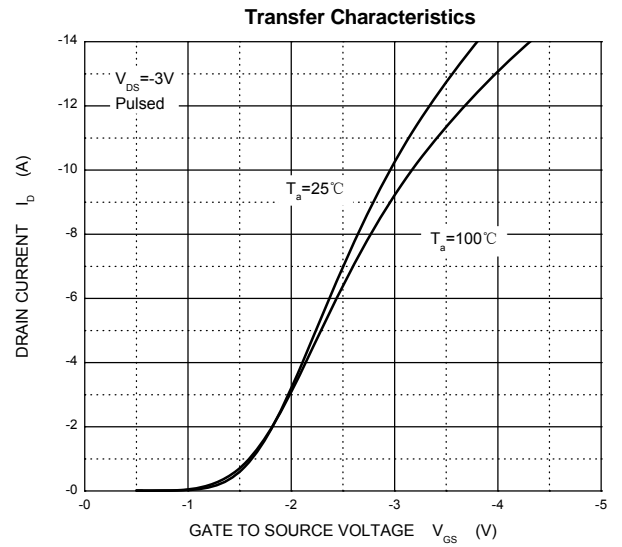
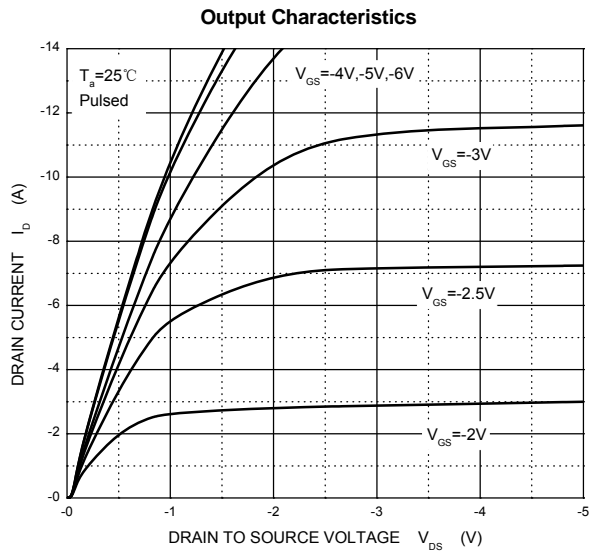

## SOT-23-6L Package Outline Dimensions

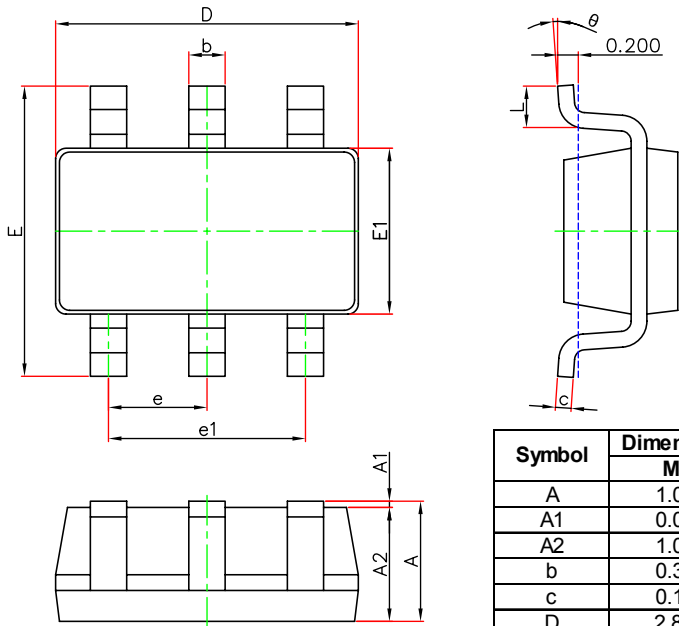

Symbol	Dimensions In Millimeters		Dimensions In Inches	
	Min.	Max.	Min.	Max.
A	1.050	1.250	0.041	0.049
A1	0.000	0.100	0.000	0.004
A2	1.050	1.150	0.041	0.045
b	0.300	0.500	0.012	0.020
c	0.100	0.200	0.004	0.008
D	2.820	3.020	0.111	0.119
E1	1.500	1.700	0.059	0.067
E	2.650	2.950	0.104	0.116
e	0.950(BSC)		0.037(BSC)	
e1	1.800	2.000	0.071	0.079
L	0.300	0.600	0.012	0.024
$\theta$	0°	8°	0°	8°

## SOT-23-6L Suggested Pad Layout

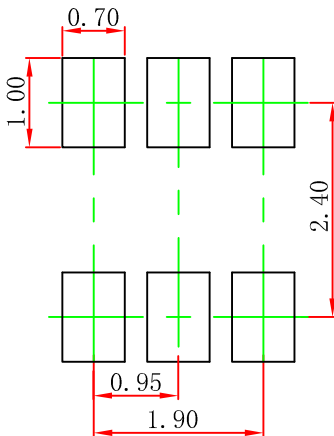

- Note:
1. Controlling dimension: in millimeters.
  2. General tolerance:  $\pm 0.05$ mm.
  3. The pad layout is for reference purposes only.

### NOTICE

JSCJ reserves the right to make modifications, enhancements, improvements, corrections or other changes without further notice to any product herein. JSCJ does not assume any liability arising out of the application or use of any product described herein.

# SOT-23-6L Tape and Reel

## SOT-23-6L Embossed Carrier Tape

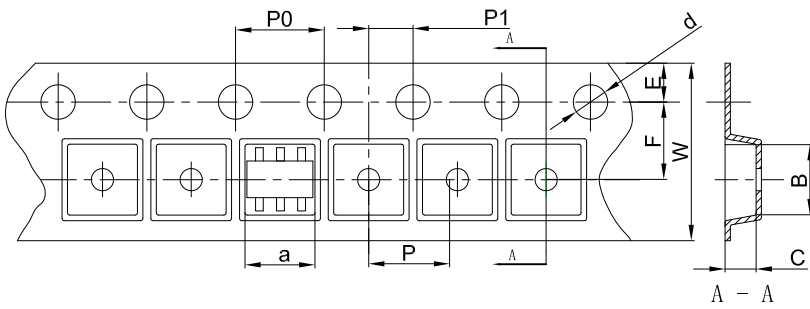

### Packaging Description:

SOT-23-6L parts are shipped in tape. The carrier tape is made from a dissipative (carbon filled) polycarbonate resin. The cover tape is a multilayer film (Heat Activated Adhesive in nature) primarily composed of polyester film, adhesive layer, sealant, and anti-static sprayed agent. These reeled parts in standard option are shipped with 3,000 units per 7" or 18.0cm diameter reel. The reels are clear in color and is made of polystyrene plastic (anti-static coated).

Dimensions are in millimeter										
Pkg type	a	B	C	d	E	F	P0	P	P1	W
SOT-23-6L	3.23	3.17	1.37	Ø1.55	1.75	3.50	4.00	4.00	2.00	8.00

## SOT-23-6L Tape Leader and Trailer

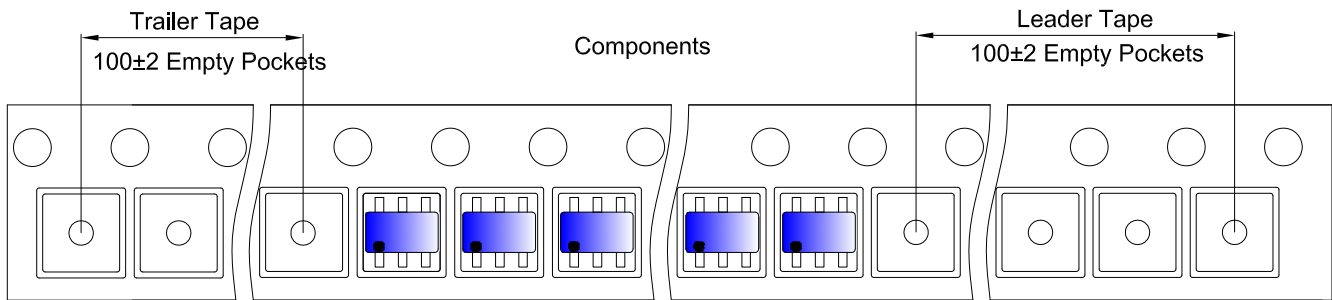

## SOT-23-6L Reel

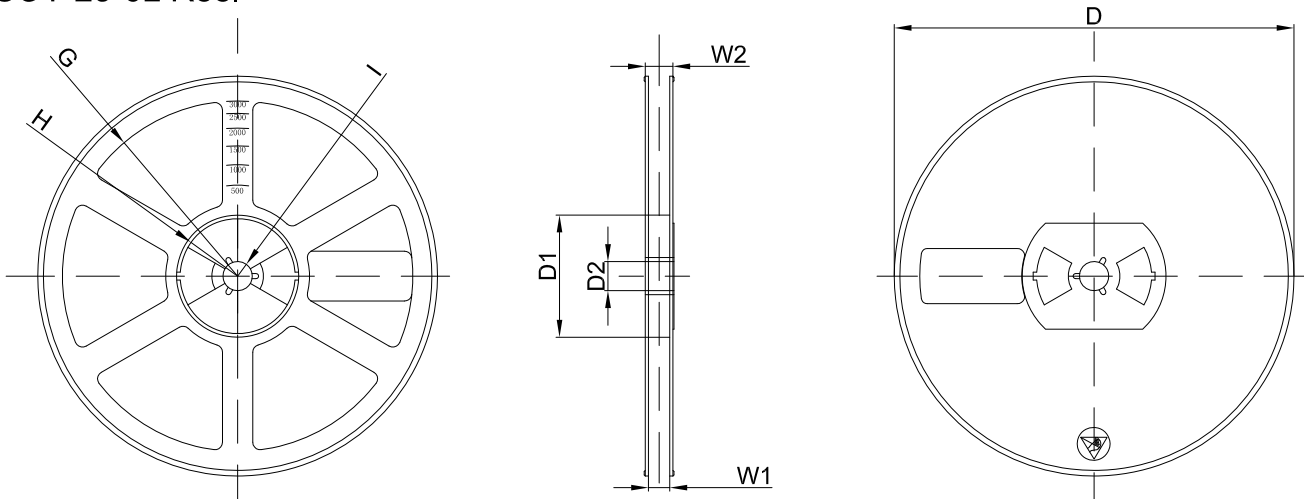

Dimensions are in millimeter								
Reel Option	D	D1	D2	G	H	I	W1	W2
7" Dia	Ø180.00	60.00	13.00	R78.00	R25.60	R6.50	9.50	13.10

REEL	Reel Size	Box	Box Size(mm)	Carton	Carton Size(mm)	G.W.(kg)
3000 pcs	7 inch	30,000 pcs	203×203×195	120,000 pcs	438×438×220	