

# ATM2320KNSA

## 20V N-Channel Enhancement Mode MOSFET

### Descriptions

The ATM2320KNSA is N-Channel logic enhancement mode power field effect transistor which is produced using high cell density advanced trench technology to provide excellent  $R_{DS(ON)}$ .

This high density process is especially tailored to minimize on-state resistance. The device is particularly suited for low voltage application, and low in-lin power loss are needed in a very small outline surface mount package.

### SOT-23

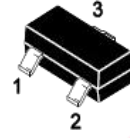

1.Gate 2.Source 3.Drain

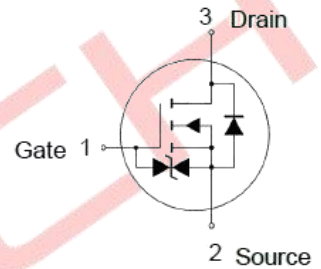

### Features

- $R_{DS(ON)} = 14m\Omega$  (typ.) @  $V_{GS}=4.5V$
- $R_{DS(ON)} = 18m\Omega$  (typ.) @  $V_{GS}=2.5V$
- Super high design for extremely low  $R_{DS(ON)}$
- Exceptional on-resistance and Maximum DC current capability
- This is a full RoHS compliance
- SOT-23 package design
- ESD Rating:2000V HBM

### Applications

- Power Management in Note Book
- Portable Equipment
- Battery Powered System

### Absolute Maximum Ratings (Ta=25°C unless otherwise specified)

Parameter		Symbol	Maximum		Units
Drain-Source Voltage		VDS	20		V
Gate-Source Voltage		VGS	± 8		V
Drain Current-Continuous		ID	5		A
Drain Current-Pulsed		IDM	30		A
Power Dissipation		PD	1.2		W
Operating Junction and Storage Temperature Range		TJ,TSTG	150, -55 ~ +150		°C
Parameter		Symbol	Typ	Max	Unit
Maximum Junction-to-Ambient	t ≤ 10s	R <sub>θJA</sub>	64	83	°C/W
Maximum Junction-to-Ambient	Steady-State		89	120	°C/W
Maximum Junction-to-Lead	Steady-State	R <sub>θJL</sub>	53	70	°C/W

# ATM2320KNSA

## Electrical Characteristics (Ta=25°C unless otherwise specified)

Parameter	Symbol	Test Conditions	Min	Typ	Max	Unit
<b>Static Parameters</b>						
Drain-Source breakdown voltage	BVDSS	ID=250uA, VGS=0V	20	-	-	V
Zero Gate voltage drain current	IDSS	VDS=16V, VGS=0V	-	-	1	uA
Gate-Body leakage current	IGSS	VDS=0V, VGS=±4.5V	-	-	±1	uA
		VDS=0V, VGS=±8V			±10	uA
Gate Threshold voltage	VGS(th)	VGS=VDS, ID=250uA	0.4	0.6	1	V
On state drain current	ID(ON)	VGS=4.5V, VDS=5V	30	-	-	A
Static Drain-source on-resistance	RDS(on)	VGS=4.5V, ID=5A		14	25	mΩ
		VGS=2.5V, ID=3A		18	35	mΩ
Forward Transconductance	gFS	VDS=5V, ID=5A	-	31	-	S
Diode Forward Voltage	VSD	Is=1A, VGS=0V	-	0.7	1.3	V
Maximum Body-Diode Continuous Current	Is		-	-	2.5	A
<b>Dynamic Parameters</b>						
Input Capacitance	Ciss	VGS=0V, VDS=10V, f=1MHZ	-	1120	-	pF
Output capacitance	Coss		-	195	-	pF
Reverse transfer capacitance	Crss		-	155	-	pF
Gate resistance	Rg	VGS=0V, VDS=0V, f=1MHZ	-	4.0	-	Ω
<b>Switching Parameters</b>						
Total Gate charge	Qg	VGS=4.5V, VDS=10V, ID=5A	-	16	-	nC
Gate Source charge	Qgs		-	1.7	-	nC
Gate Drain charge	Qgd		-	6.8	-	nC
Turn-on delaytime	tD(on)	VGS=5V, VDD=10V, RL=1.35 Ω, RGEN=3 Ω	-	7.2	-	ns
Turn-on rise time	tr		-	11	-	ns
Turn-off delaytime	tD(off)		-	64	-	ns
Turn-off fall time	tf		-	32	-	ns
Body Diode reverse recovery Time	trr	IF=5A, dI/dt=100A/us	-	32	-	ns
Body diode reverse recovery charge	Qrr	IF=5A, dI/dt=100A/us	-	12	-	nC

Notes:

1. Pulse test: pulse width≤300uS, duty cycle≤2%
2. Static parameters are based on package level with recommended wire bonding

# ATM2320KNSA

## Typical Characteristics Curves

**Power Dissipation**

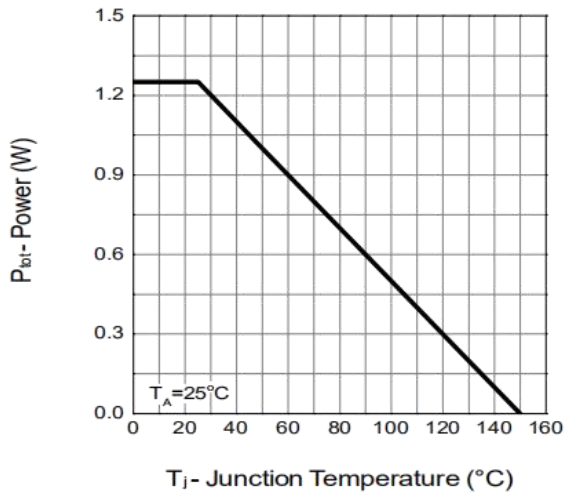

**Drain Current**

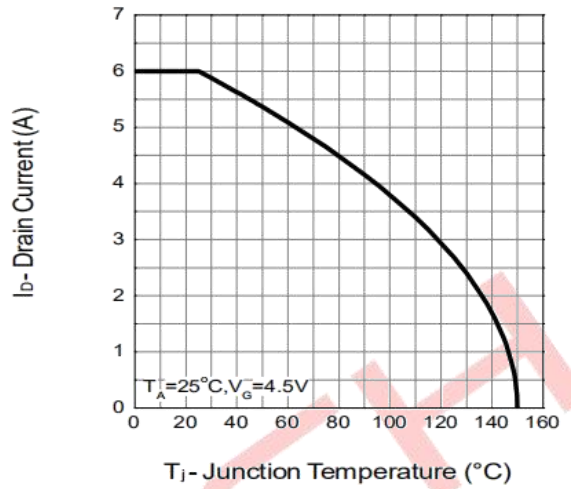

**Safe Operation Area**

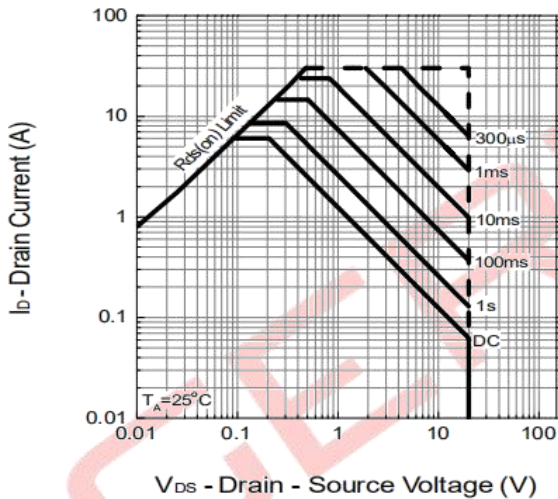

**Thermal Transient Impedance**

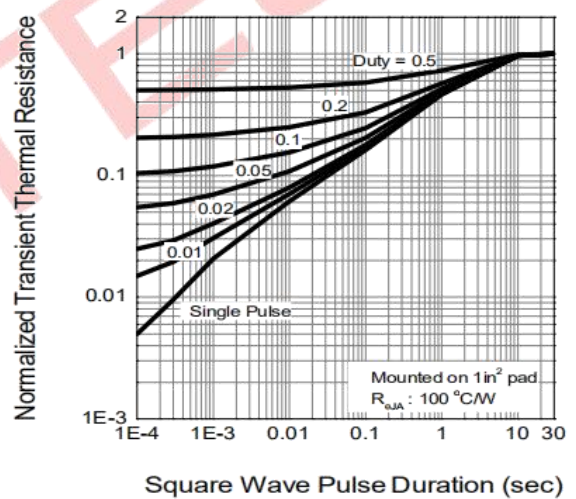

**Output Characteristics**

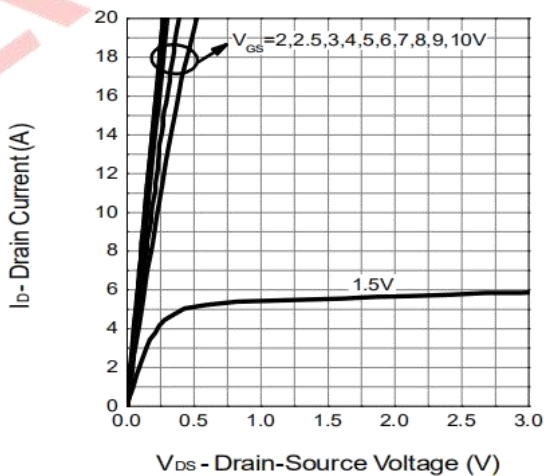

**Drain-Source On Resistance**

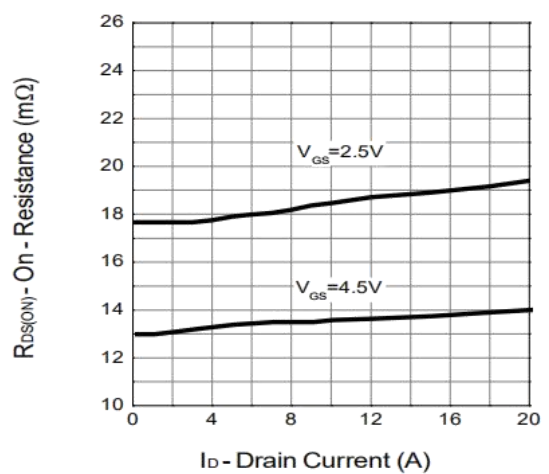

**Gate-Source On Resistance**

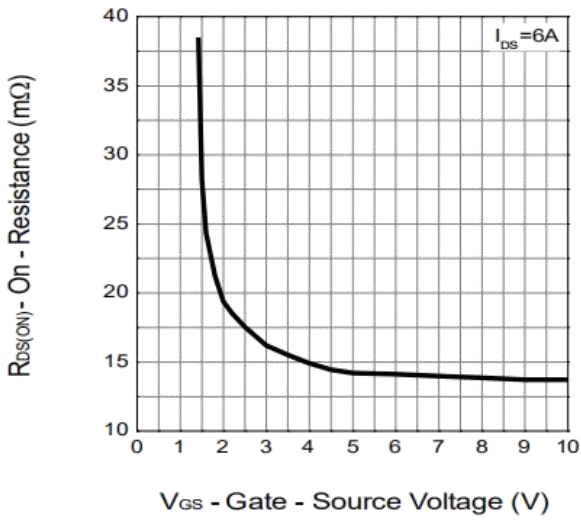

**Gate Threshold Voltage**

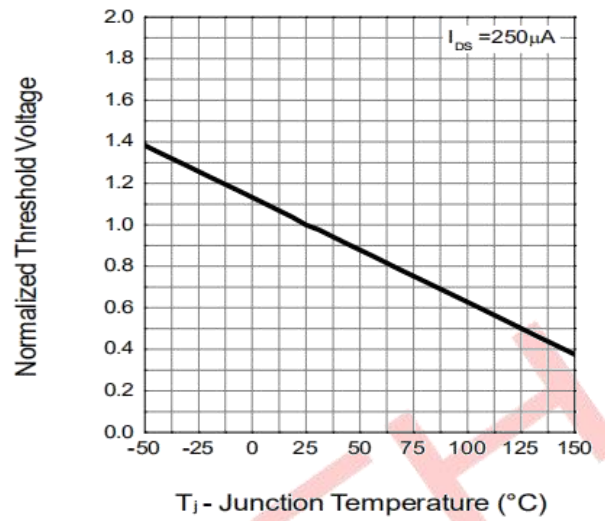

**Drain-Source On Resistance**

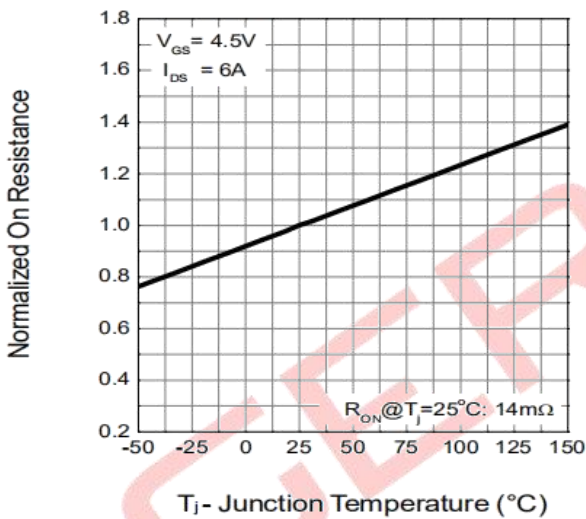

**Source-Drain Diode Forward**

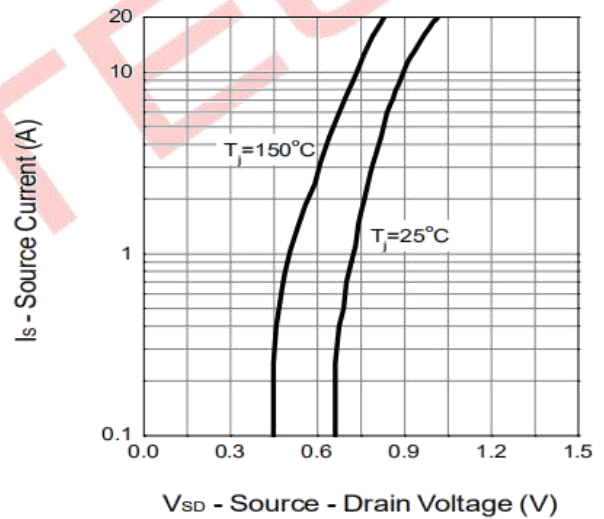

**Capacitance**

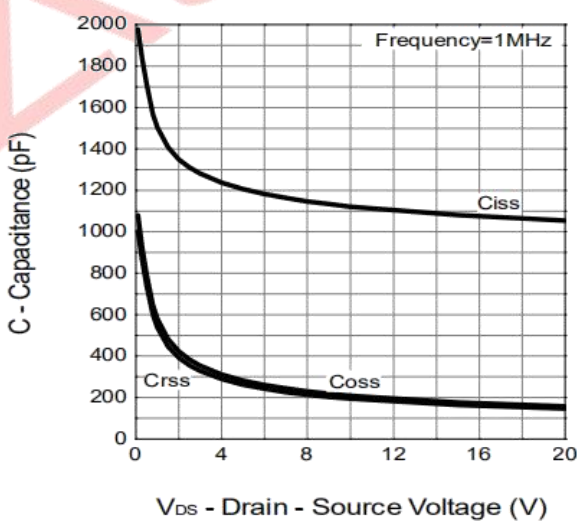

**Gate Charge**

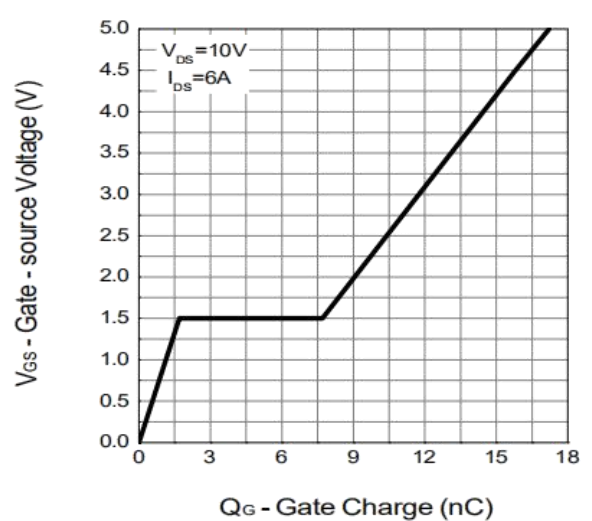

# ATM2320KNSA

## Package outline

### SOT-23

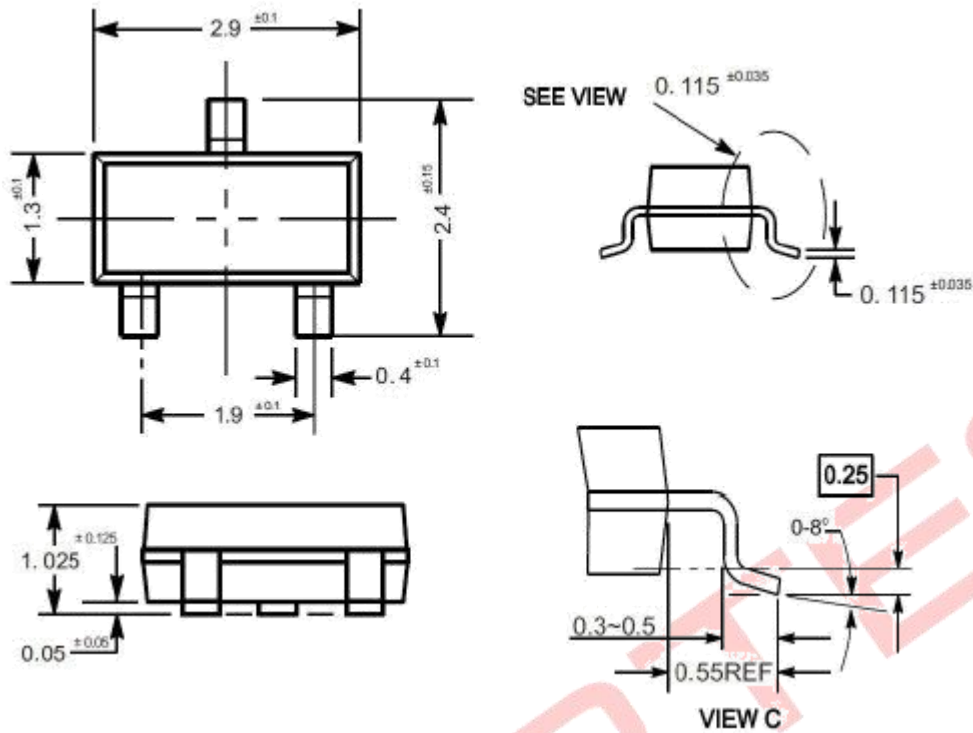

### Ordering information

Device	Package	Marking	Shipping
ATM2320KNSA	SOT-23	2320	3000PCS/Reel&Tape(7inch)