

TF-FUSE® Thin Film Surface Mount Fuses

HI Series (High Inrush), 0603 Size

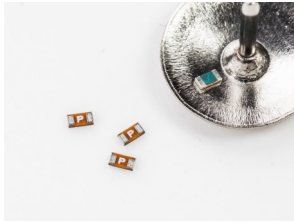

Features:

- Low DCR
- High inrush current withstanding capability
- Fiberglass enforced epoxy fuse body
- Copper termination with nickel and tin plating
- Halogen free, RoHS compliance and lead-free

Clearing Time Characteristics:

% of Current Rating	Opening Time at 25°C	
	100%	4 hours min.
200%	1 second min.	60 seconds max.
1000%	0.0002 second min.	0.02 second max.

Shape and Dimensions:

Unit	Inch	mm
Length (L)	0.063 ± 0.004	1.60 ± 0.10
Width (W)	0.032 ± 0.004	0.81 ± 0.10
Thickness (T)	0.014 ± 0.004	0.36 ± 0.10
Termination bandwidth (b)	0.014 ± 0.004	0.36 ± 0.10

Applications:

- Power tools
- DC-DC convert
- Panel
- PC
- Server
- Battery pack
- Set top box

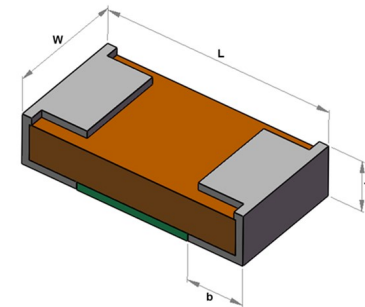

Agency Approval:

Recognized Under the Components Program of UL.
File Number: E232989.

Typical Ratings and Characteristics:

Operating temperature: -55 to +90°C

Part Number	Current Rating (A)	Voltage Rating (Vdc)	Interrupting Rating	Nominal Cold DCR (Ω) ¹	Nominal I ² t (A ² s) ²	Marking
T0603HI0500TM	0.50	65	50A@35Vdc/ac 13A@65Vdc	0.1550	0.019	C
T0603HI0750TM	0.75	65		0.0830	0.036	D
T0603HI1000TM	1.00	65		0.0500	0.052	E
T0603HI1500TM	1.50	65		0.0290	0.110	T
T0603HI2000TM	2.00	35	35A@35Vdc/ac 50A@24Vdc/ac	0.0200	0.310	F
T0603HI2500TM	2.50	35		0.0165	0.400	J
T0603HI3000TM	3.00	35		0.0140	0.600	L
T0603HI3500TM	3.50	35		0.0120	0.800	N
T0603HI4000TM	4.00	35		0.0095	1.200	P

¹ Measured at ≤ 10% of rated current and 25°C ambient.

² Melting I²t at 0.001 sec.

TF-FUSE® Thin Film Surface Mount Fuses
HI Series (High Inrush), 0603 Size

Average Pre-arcing Time Curves:

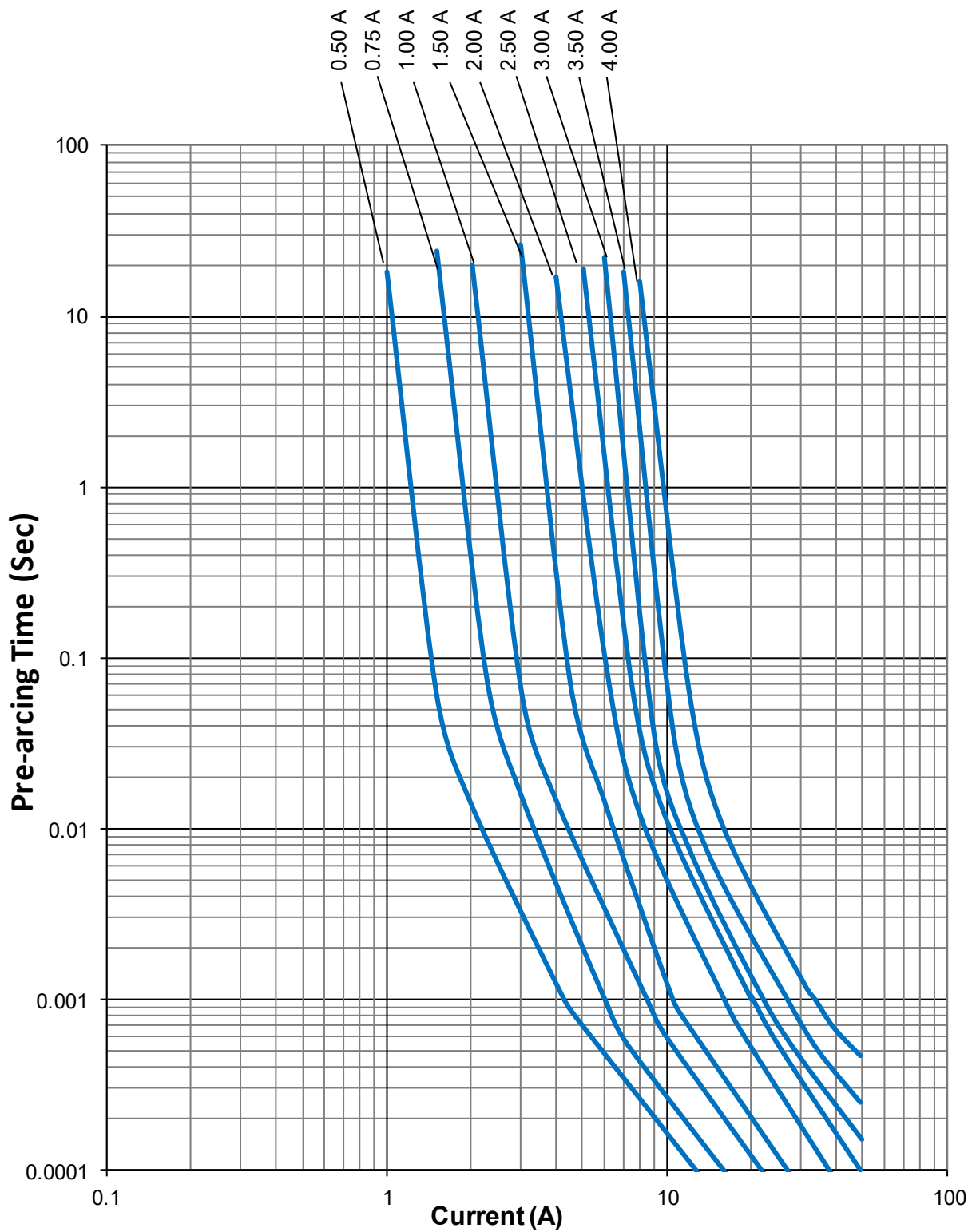

TF-FUSE® Thin Film Surface Mount Fuses
HI Series (High Inrush), 0603 Size

Average I^2t vs. t Curves:

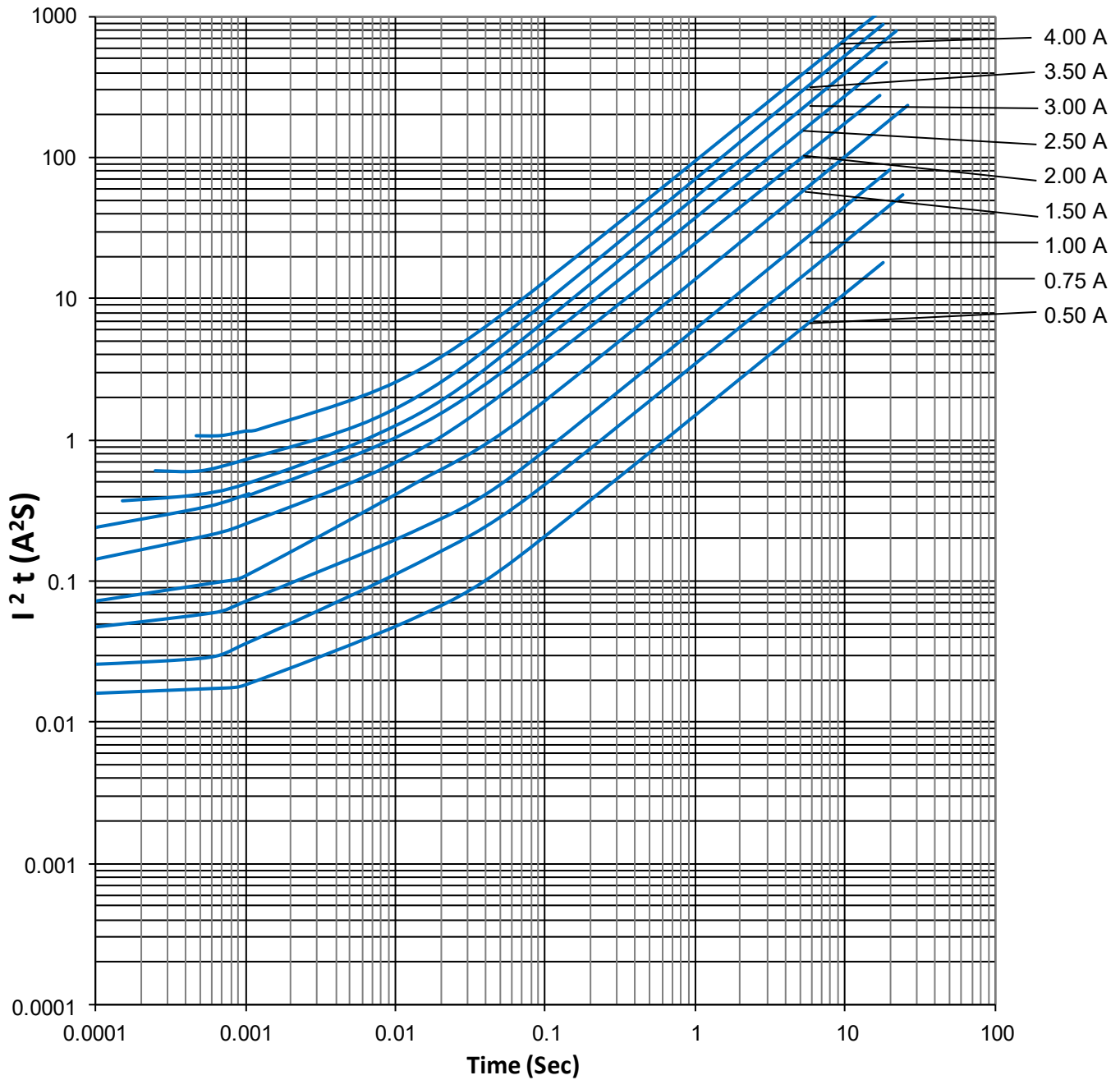

TF-FUSE® Thin Film Surface Mount Fuses

Product Identification:

T 0603 FF 1000 T M

(1) (2) (3) (4) (5) (6)

(1) **Product Code:** T—Thin Film

(2) **Size Code:** Standard EIA chip sizes

(3) **Series Code:** FF—Very Fast Acting, HI—High Inrush

(4) **Current Rating Code:** 0500—0.5A, 1000—1.0A

(5) **Package Code:** T—Tape & Reel; B—Bulk

(6) **Marking Code:** M—With mark (optional)

Environmental Tests:

No.	Test item	Test Condition and Requirement	Reference
1	Bend	2 mm bend, DCR change within $\pm 20\%$. ($\pm 10\%$ for $\leq 1A$), no mechanical damage	IEC60068-2-21
2	Solderability	245°C, 5 seconds, new solder coverage $\geq 95\%$	MIL-STD-202 Method 208
3	Thermal shock	DCR change $\leq \pm 10\%$. No mechanical damage. 100 cycles between -55°C and +125°C	MIL-STD-202 Method 107
4	Moisture resistance	10 cycles, DCR change within $\pm 10\%$, no excessive corrosion	MIL-STD-202 Method 106
5	Salt spray	DCR change $\leq \pm 10\%$. No excessive corrosion. 5% salt solution, 48 hour exposure	MIL-STD-202 Method 101
6	Mechanical vibration	DCR change $\leq \pm 10\%$. No mechanical damage. 0.4" D.A. or 30G between 5 and 3000 Hz	MIL-STD-202 Method 204
7	Mechanical shock	DCR change $\leq \pm 10\%$. No mechanical damage. 1500G, 0.5 ms, half sine shocks	MIL-STD-202 Method 213
8	Life	75% rated current, 2000 hours at ambient temperature from +20°C to 30 °C, no open circuit, voltage drop change within $\pm 10\%$	Refer to AEM QIQ106

Moisture Sensitivity Level 1

Packaging:

Chip Size	Parts on 7 inch (178mm) Reel
0603 (1608)	8,000
0402 (1005)	20,000

TF-FUSE® Thin Film Surface Mount Fuses

Temperature Effect on Current Rating:

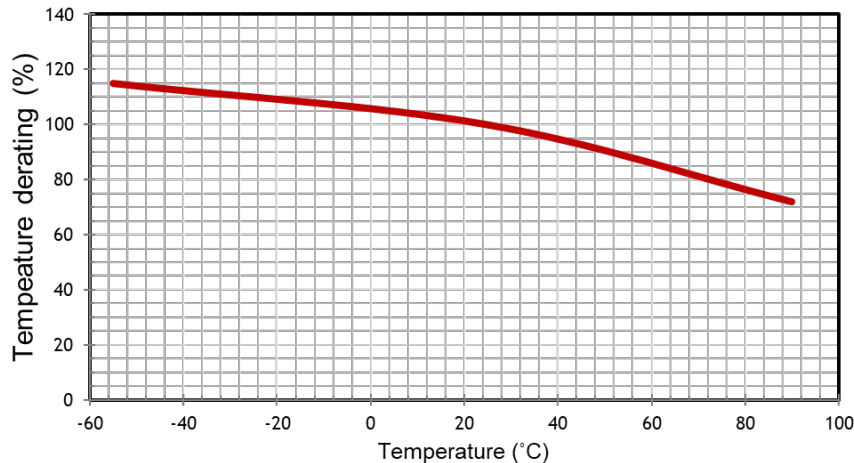

Recommended Reflow Soldering Profile:

Profile Feature	Pb-Free Assembly
Preheat/Soak	
Temperature Min (T_{smin})	150°C
Temperature Max (T_{smax})	200°C
Time (t_s) from (T_{smin} to T_{smax})	60~120 seconds
Ramp-uprate (T_L to T_p)	3°C/second max.
Liquidous temperature (T_L)	217°C
Time (t_L) maintained above T_L	60~150 seconds
Peak package body temperature (T_p)	260°C
Time (t_p)*within 5°C of the specified classification temperature (T_c)	30 seconds *
Ramp-down rate (T_p to T_L)	6°C/second max.
Time 25°C to peak temperature	8 minutes max.
* Tolerance for peak profile temperature (T_p) is defined as a supplier minimum and a user maximum	

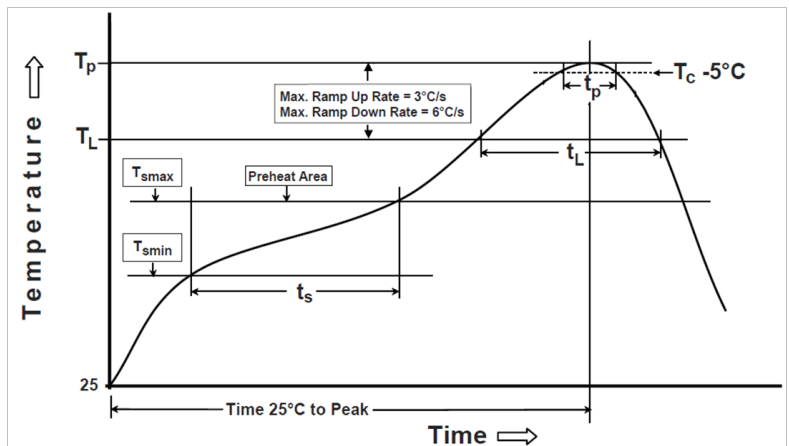

Thermal Shock When Making Correction with a Soldering Iron:

The temperature of solder iron tip should be controlled under 350°C and soldering time should be less than 3 sec.

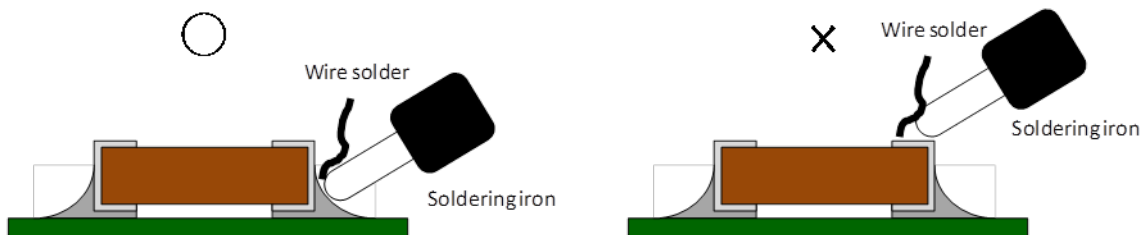

Fig 3 Correct handling method of soldering iron

Disclaimer

Specifications are subject to change without notice. AEM products are designed for specific applications and should not be used for any purpose (including, without limitation, automotive, aerospace, medical, life-saving applications, or any other application which requires especially high reliability for the prevention of such defect as may directly cause damage to the third party's life, body or property) not expressly set forth in applicable AEM product documentation. It is the customer's responsibility to validate that a particular product with the properties described in the product specification is suitable for use in a particular application. Warranties granted by AEM shall be deemed void for products used for any purpose not expressly set forth in applicable AEM product documentation. AEM shall not be liable for any claims or damages arising out of products used in applications not expressly intended by AEM as set forth in applicable AEM product documentation. The sale and use of AEM products is subject to AEM terms and conditions of sale. Please refer to AEM's website for updated catalog and terms and conditions of sale.