

## 1-Line Bidirectional ESD Protection Diode

### General description

These surge protection diodes are designed for applications requiring transient overvoltage protection capability. They are intended for use in voltage and ESD sensitive equipment such as computers, printers, business machines, communication systems, medical equipment and other applications. These devices are ideal for situations where board space is at a premium.

### Features and benefits

- . Bidirectional ESD protection of one line
- . Reverse stand-off voltage: 3.3V Max
- . Low leakage current: nA Level
- . Response time is typically < 1 ns
- . Low clamping voltage:  $V_C < 12\text{ V @ } I_{PP} = 38\text{ A}$
- . ESD Protection: 30kV(air)/ 30kV(contact) ( IEC61000-4-2)
- . RoHS compliant

### Application information

- . Cell Phone Handsets and Accessories
- . Microprocessor based equipment
- . Personal Digital Assistants (PDA's)
- . Notebooks, Desktops, and Servers

### Ordering information

Device	Package	Marking	Packaging
SD03C	SOD323	3/8	3000/Tape & Reel

### Schematic & Pin configuration

Simplified outline	Graphic symbol
	

**Maximum Ratings** ( $T_{OP} = 25 \text{ } ^\circ\text{C}$ , unless otherwise specified)

Parameter	Symbol	Value	Unit
Peak Pulse Power ( $t_p = 8/20 \text{ } \mu\text{s}$ )	$P_{PPM}$	450	W
Peak Pulse Current( $t_p = 8/20 \text{ } \mu\text{s}$ )	$I_{PPM}$	38	A
ESD voltage IEC 61000-4-2 (air discharge)	$V_{ESD}$	30	kV
ESD voltage IEC 61000-4-2 (contact discharge)	$V_{ESD}$	30	kV
Maximum lead temperature for soldering during 10s	$T_L$	260	$^\circ\text{C}$
Storage Temperature Range	$T_{stg}$	-55 to +150	$^\circ\text{C}$
Operating Temperature Range	$T_{OP}$	-40 to +125	$^\circ\text{C}$

**Electrical Characteristics** ( $T_{OP} = 25 \text{ } ^\circ\text{C}$ , unless otherwise specified)

Parameter	Symbol	Min	Typ	Max	Unit	Condition
Reverse Working Voltage	$V_{RWM}$	--	--	3.3	V	
Breakdown Voltage	$V_{BR}$	4.0	--	6.0	V	$I_T=1\text{mA}$
Leakage Current $I_{Leak}$	$I_R$	--	--	200	nA	$V_{RWM}=3.3\text{V}$
Clamping Voltage	$V_C$	--	--	8.5	V	$I_{PP}=20\text{A}, T_p=8/20\mu\text{s}$
		--	--	12.0		$I_{PP}=38\text{A}, T_p=8/20\mu\text{s}$
Dynamic Resistance	$R_{DYN}$	--	0.1	--	$\Omega$	$T_{LP}=0.2/100\text{ns}$
Junction Capacitance	$C_J$	--	50	70	pF	$V_R=0\text{V}, f=1\text{MHz}$

Note:

TLP Setting:  $t_p=100\text{ns}$ ,  $t_r=0.2\text{ns}$ , ITLP and VTLP sample window:  $t_1=70\text{ns}$  to  $t_2=90\text{ns}$ .

### Typical Characteristics

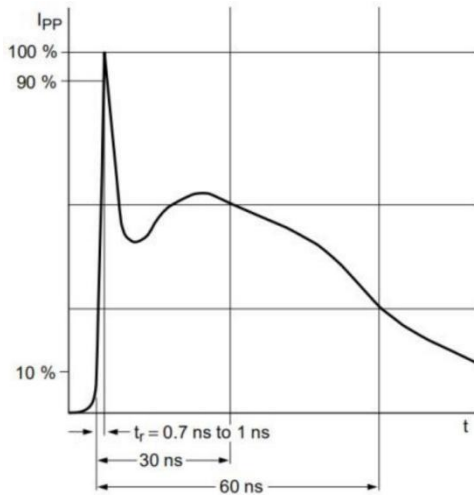

IEC61000-4-2 Waveform

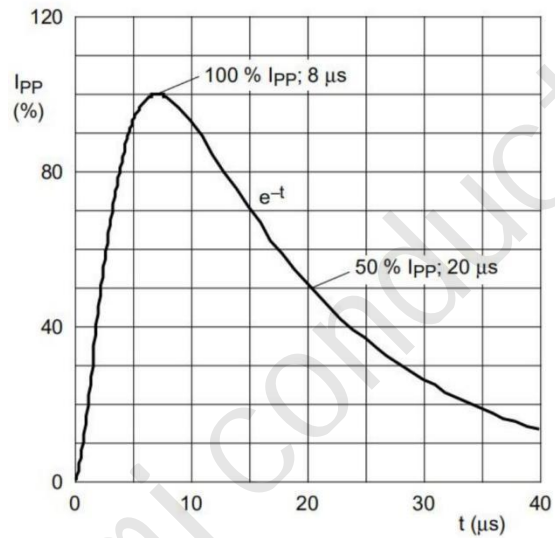

IEC 61000-4-5 Waveform( 8/20μs pulse)

### Package Outline Dimensions

SOD323

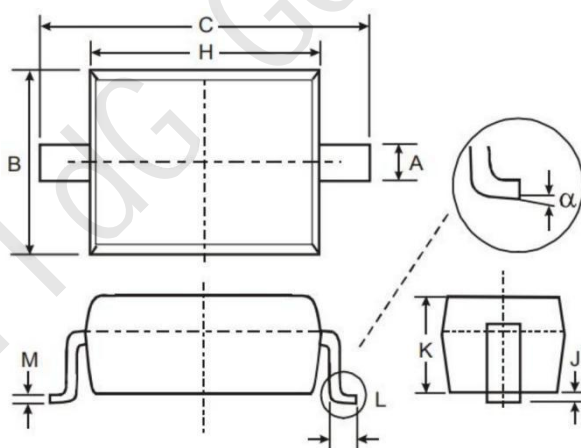

SYMBOL	MILLIMETERS	
	MIN	MAX
A	0.25	0.35
B	1.20	1.40
C	2.40	2.70
H	1.60	1.80
J	0.01	0.15
K	0.80	1.00
L	0.20	0.40
M	0.08	0.15
“	0°	8°