



1-Line Uni-directional ESD Protection Diode

General description

The ESD8FT5.0 is an uni-directional TVS diode, utilizing leading monolithic silicon technology to provide fast response time and low ESD clamping voltage, making this device an ideal solution for protecting voltage sensitive data and power line. The ESD8FT5.0 complies with the IEC 61000-4-2 (ESD) standard with $\pm 30\text{kV}$ air and $\pm 30\text{kV}$ contact discharge. It is assembled into an ultra-small 1.0x0.6x0.5mm lead-free DFN package. The small size and high ESD surge protection make ESD8FT5.0 an ideal choice to protect cell phone, digital cameras, audio players and many other portable applications.

Features and benefits

- Complies with following standards:
 - IEC 61000-4-2 (ESD) immunity test
 - Air discharge: $\pm 30\text{kV}$
 - Contact discharge: $\pm 30\text{kV}$
 - IEC61000-4-5 (Lightning) 50A (8/20 μs)
- Low clamping voltage
- Ultra small package: 1.0x0.6x0.5mm
- RoHS Compliant

Application information

- Hand Held Portable Applications
- Vbat pin for Mobile Devices
- Battery Protection
- Power Line Protection
- Mobile Phones
- Portable electronics

Ordering information

Device	Package	Packaging	Reel Size
ESD8FT5.0	DFN1006-2L	10000/Tape & Reel	7 Inch

Schematic & Pin configuration

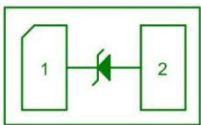
Graphic symbol	Pin	Symbol	Description
	1	K	Cathode
	2	A	Anode

Maximum Ratings ($T_{OP} = 25\text{ }^{\circ}\text{C}$, unless otherwise specified)

Parameter	Symbol	Value	Unit
Peak Pulse Power ($T_p = 8/20\ \mu\text{s}$)	P_{PPM}	550	W
Rated Peak Pulse Current ($T_p = 8/20\ \mu\text{s}$)	I_{PPM}	50	A
ESD voltage IEC 61000-4-2 (air discharge)	V_{ESD}	30	kV
ESD voltage IEC 61000-4-2 (contact discharge)	V_{ESD}	30	kV
Maximum lead temperature for soldering during 10s	T_L	260	$^{\circ}\text{C}$
Storage Temperature Range	T_{stg}	-55 to +150	$^{\circ}\text{C}$
Operating Temperature Range	T_{OP}	-40 to +125	$^{\circ}\text{C}$

Electrical Characteristics ($T_{OP} = 25\text{ }^{\circ}\text{C}$, unless otherwise specified)

Parameter	Symbol	Min	Typ	Max	Unit	Condition
Reverse Working Voltage	V_{RWM}	--	--	5.0	V	
Breakdown Voltage	V_{BR}	5.6	6.1	7.6	V	$I_T=1\text{mA}$
Leakage Current I_{Leak}	I_R	--	--	0.1	μA	$V_{RWM}=5.0\text{V}$
Forward Voltage	V_F	0.6	--	1.1	V	$I_F=10\text{mA}$
Forward Clamping Voltage	V_{CF}	--	--	8.5	V	$I_{PP}=40\text{A}, T_p=8/20\mu\text{s}$
Reverse Clamping Voltage	V_{CR}	--	9.0	11.0	V	$I_{PP}=50\text{A}, T_p=8/20\mu\text{s}$
Junction Capacitance	C_j	--	100	150	pF	$V_R=0\text{V}, f=1\text{MHz}$

Portion Electronics Parameter

Symbol	Parameter
I_{PP}	Maximum Reverse Peak Pulse Current
V_C	Clamping Voltage @ I_{PP}
V_{RWM}	Working Peak Reverse Voltage
I_R	Reverse Leakage Current @ V_{RWM}
I_T	Test Current
V_{BR}	Breakdown Voltage @ I_T
I_F	Forward Current
V_F	Forward Voltage @ I_F

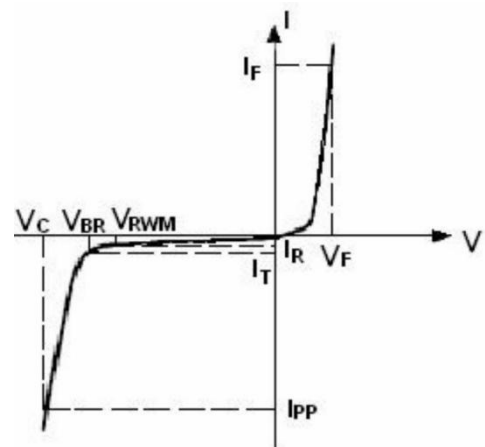

Typical Performance Characteristics ($T_A=25\text{ }^\circ\text{C}$ unless otherwise Specified)

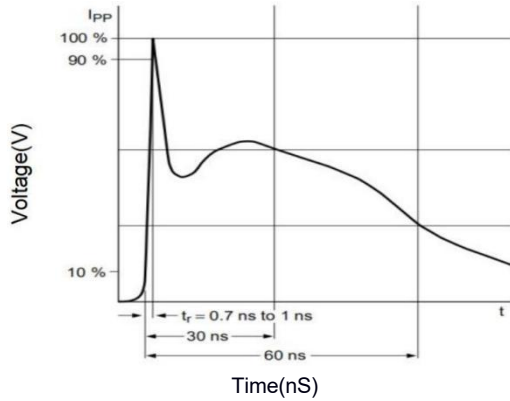

IEC61000-4-2 Pulse Waveform

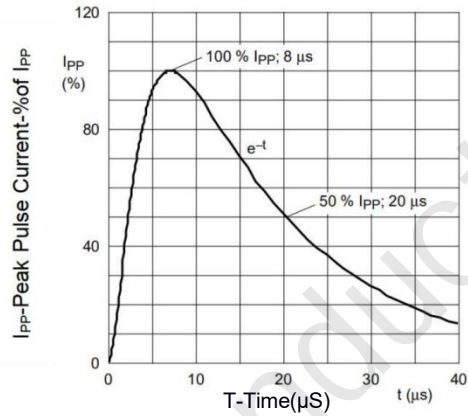

IEC61000-4-5 8X20µs Pulse Waveform

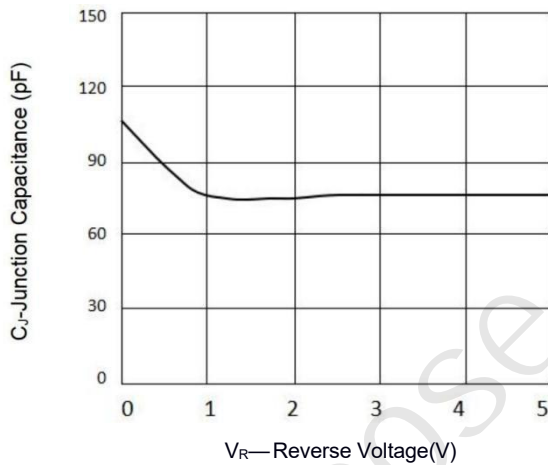

Junction Capacitance vs. Reverse Voltage

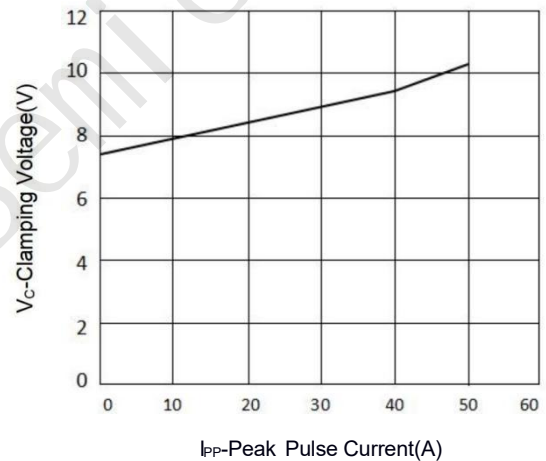

Clamping Voltage vs. Peak Pulse Current



Peak Pulse Power vs. Pulse Time

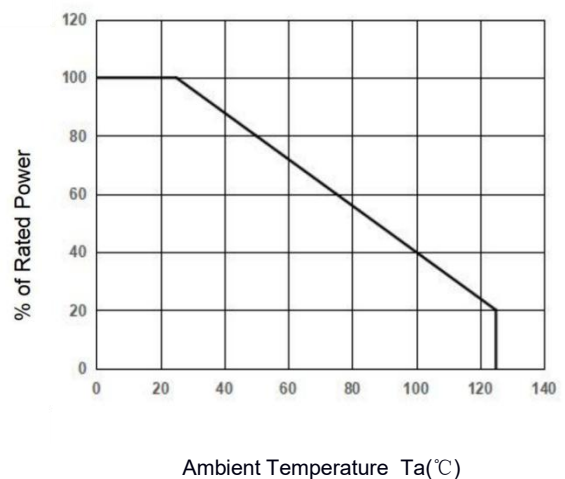

Power Derating Curve

Package Outline Dimensions

DFN1006-2L

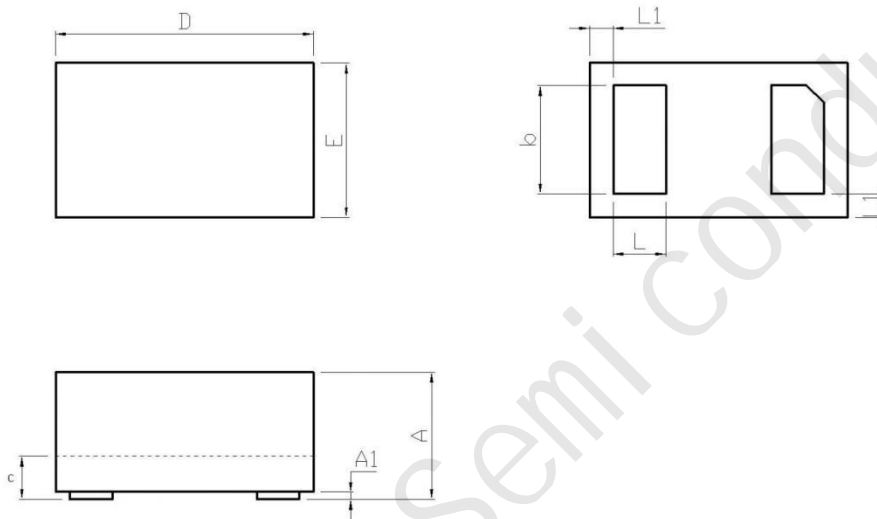

DFN1006-2L (mm)			
Dim	Min	Typ.	Max
A	0.45	0.50	0.55
A1	0	0.02	0.05
b	0.45	0.5	0.55
c	0.12	0.15	0.18
D	0.95	1.00	1.05
E	0.55	0.60	0.65
L	0.20	0.25	0.30
L1	0.035	0.05	0.065