



1-Line Bidirectional ESD Protection Diode

General description

The ESD3Z3.3C is designed to protect voltage sensitive components from ESD and transient voltage events. Excellent clamping capability, low leakage, and fast response time, make these parts ideal for ESD protection on designs where board space is at a premium.

Features and benefits

- Bidirectional ESD protection of one line
- Reverse stand-off voltage: 3.3V Max
- Low leakage current: nA Level
- Response time is typically < 1 ns
- Low clamping voltage: $V_C < 9.0\text{ V @ } I_{PP} = 11\text{ A}$
- ESD Protection: 30kV(air)/ 30kV(contact) (IEC61000-4-2)
- RoHS compliant

Application information

- Cell Phone Handsets and Accessories
- Microprocessor based equipment
- Personal Digital Assistants (PDA's)
- Notebooks, Desktops, and Servers

Ordering information

Par Number	Package	Packaging	Reel Size
ESD3Z3.3C	SOD323	3000/Tape & Reel	7 inch

Schematic & Pin configuration

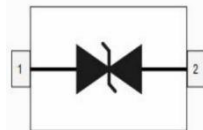
Simplified outline	Graphic symbol
	

Maximum Ratings ($T_{OP} = 25 \text{ } ^\circ\text{C}$, unless otherwise specified)

Parameter	Symbol	Value	Unit
Peak Pulse Power ($t_p = 8/20 \mu\text{s}$)	P_{PPM}	100	W
Peak Pulse Current($t_p = 8/20 \mu\text{s}$)	I_{PPM}	11	A
ESD voltage IEC 61000-4-2 (air discharge)	V_{ESD}	30	kV
ESD voltage IEC 61000-4-2 (contact discharge)	V_{ESD}	30	kV
Maximum lead temperature for soldering during 10s	T_L	260	$^\circ\text{C}$
Storage Temperature Range	T_{stg}	-55 to +150	$^\circ\text{C}$
Operating Temperature Range	T_{OP}	-40 to +125	$^\circ\text{C}$

Electrical Characteristics ($T_{OP} = 25 \text{ } ^\circ\text{C}$, unless otherwise specified)

Parameter	Symbol	Min	Typ	Max	Unit	Condition
Reverse Working Voltage	V_{RWM}	--	--	3.3	V	
Breakdown Voltage	V_{BR}	3.6	--	5.0	V	$I_r=1\text{mA}$
Leakage Current I_{Leak}	I_r	--	--	100	nA	$V_{RWM}=3.3\text{V}$
Clamping Voltage	V_C	--	4.5	5.0	V	$I_{pp}=2\text{A}, T_p=8/20\mu\text{s}$
		--	7.5	9.0		$I_{pp}=11\text{A}, T_p=8/20\mu\text{s}$
Junction Capacitance	C_j	--	18	23	pF	$V_R=0\text{V}, f=1\text{MHz}$

Typical Electrical and Thermal Characteristics (Curves)

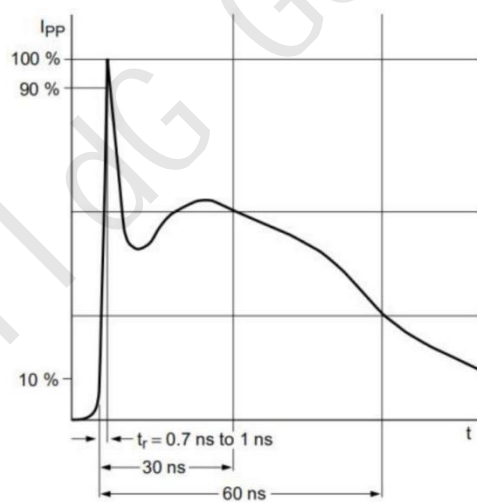

IEC61000-4-2 Waveform

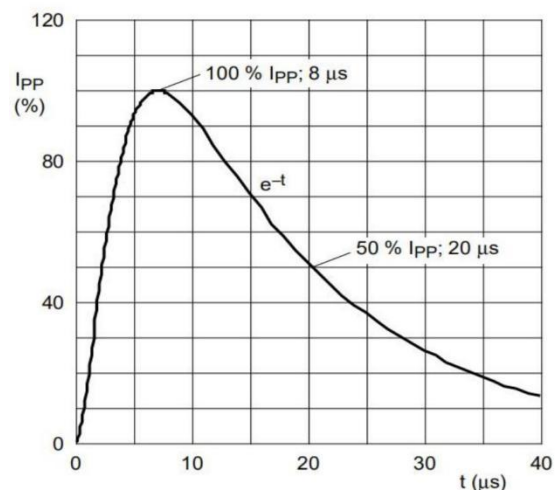

IEC 61000-4-5 Waveform(8/20µs pulse)

Package Outline Dimensions

SOD323

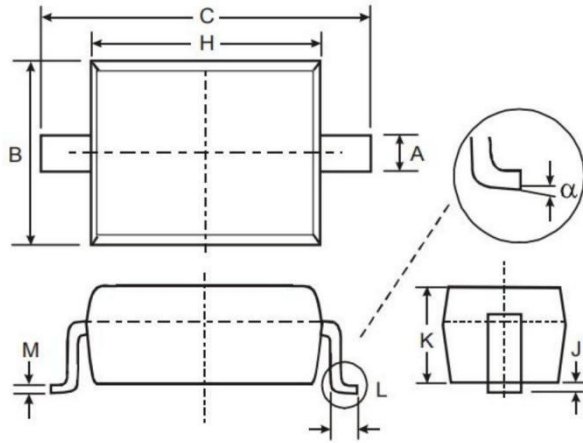

SYMBOL	MILLIMETERS	
	MIN	MAX
A	0.25	0.35
B	1.20	1.40
C	2.40	2.70
H	1.60	1.80
J	0.01	0.15
K	0.80	1.00
L	0.20	0.40
M	0.08	0.15
“	0°	8°

Soldering Footprint (mm)

