

SUL6018

1.3 μ A, High PSRR, 350mA Low-Dropout Linear Regulator

FUNCTIONAL DESCRIPTION

The SUL6018 is an ultra-small, ultra-low quiescent current low-dropout linear regulator (LDO) that can source 350mA with excellent transient performance.

The SUL6018, with an ultra-low IQ of 1.3 μ A, is designed specifically for applications where very-low quiescent current is a critical parameter. This device maintains low IQ consumption even in dropout mode to further increase the battery life.

The feature of 1.3 μ A low quiescent current and 0.05 μ A shutdown current are ideal for the battery application with long service life. The other features include current limit function, over temperature protection and output discharge function.

The SUL6018 is available SOT-23-5 and DFN-1x1-4L Packages. Standard products are Pb-free and Halogen-free.

MAIN FEATURES

- Input Voltage Range: 1.2V to 5.5V
- Ultra Low IQ: 1.3 μ A
- High PSRR = 85dB @1KHz
- Output Voltage Range:
 - Adjustable Mode: 0.8V to 4.5V
 - Fixed Mode: 0.8V~4.5V, 0.05V step.
- High Output Accuracy: \pm 1%
- Ultra Low Dropout Voltage: 150mV @ 350mA when VOUT \geq 3V
- Low Noise: 30 μ Vrms
- Current Limit Protection
- Over Temperature Protection
- Output Active Discharge Function

APPLICATIONS

- Portable, Battery Powered Equipment
- Ultra Low Power Microcontrollers
- Notebook Computers

ORDERING INFORMATION

PART NO	PACAKGE	TEMPERATURE	TAPE & REEL
SUL6018S5-XX ^{Note}	SOT23-5L	-40 ~ +85 $^{\circ}$ C	3000/REEL
SUL6018D4-XX ^{Note}	DFN1x1-4L	-40 ~ +85 $^{\circ}$ C	10000/REEL

Note:XX indicates Vout. For example, 28 means product outputs 2.8V

PACKAGE INFORMATION & PIN DESCRIPTION

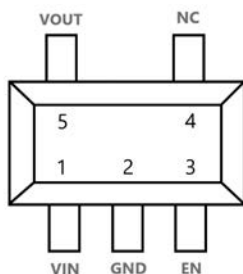

SOT-23-5 Pin Configuration (Fixed Mode)

PIN No	Symbol	Pin Description
1	VIN	Input Pin
2	GND	Ground Pin
3	EN	Chip Enable Pin
4	NC	No Connection
5	VOUT	Output Pin

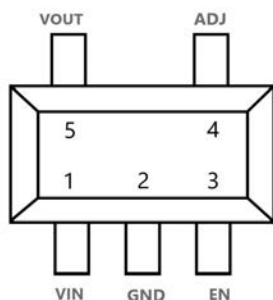

SOT-23-5 Pin Configuration (ADJ Mode)

PIN No	Symbol	Pin Description
1	VIN	Input Pin
2	GND	Ground Pin
3	EN	Chip Enable Pin
4	ADJ	No Connection
5	VOUT	Output Pin

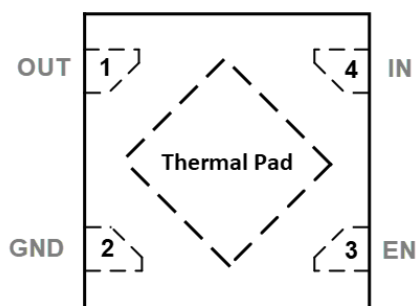

DFN1x1-4L Pin Configuration

PIN No	Symbol	Pin Description
1	VOUT	Output Pin
2	GND	Ground Pin
3	EN	Chip Enable Pin
4	VIN	Input Pin

ABSOLUTE MAXIMUM RATINGS

Symbol	Item	Rating		Unit
V _{IN}	Input Voltage	6.0		V
V _{CE}	Input Voltage (CE Pin)	-0.3 to 6.0		V
V _{OUT}	Output Voltage	-0.3 to 6.0		V
P _D	Power Dissipation (Standard Land Pattern)	SOT23-5	400	mW
T _{OP}	Junction Temperature Range	-40 to 125		°C
T _{STG}	Storage Temperature Range	-55 to 125		°C

RECOMMENDED OPERATING CONDITIONS

Symbol	Item	Rating	Unit
V _{IN}	Input Voltage	1.2 to 5.5	V
V _{OUT}	Output Voltage	0.8 to 4.5	V
T _a	Operating Temperature Range	-40 to 85	°C
C _{IN} /C _{OUT}	Input/Output Capacitance	1/1	uF

ELECTROSTATIC DISCHARGE

Symbol	Parameter	Value	Unit
ESD	Human Body Mode	± 2	kV
	Machine Mode	± 250	V
	Charge Device Mode	± 1000	V

THERMAL DATA

Symbol	Parameter	Value	Unit
θ _{JA}	Thermal resistance junction-ambient	260 (SOT23-5)	°C/W
θ _{JA}	Thermal resistance junction-ambient	250 (DFN1x1-4)	°C/W

Electrical Characteristics

($V_{OUT} + 1 < V_{IN} < 5.5V$, $T_A=25^{\circ}C$, unless otherwise specified)

Parameter	Symbol	Test Conditions	Min.	Typ.	Max.	Unit	
Fixed Output Voltage Range	V_{OUT}		0.8	--	4.5	V	
DC Output Accuracy	V_{OUT_ACC}	$I_{LOAD} = 1mA$	$V_{OUT} \geq 1.8V$	-1	--	1	%
			$V_{OUT} < 1.8V$	-1.5	--	1.5	%
Reference Voltage	V_{REF}	$I_{LOAD} = 1mA$	0.792	0.8	0.808	V	
Dropout Voltage ($I_{LOAD} = 350mA$)	V_{DROP}	$0.8V \leq V_{OUT} < 1.05V$	--	0.58	0.75	V	
		$1.05V \leq V_{OUT} < 1.2V$	--	0.4	0.56		
		$1.2V \leq V_{OUT} < 1.5V$	--	0.33	0.45		
		$1.5V \leq V_{OUT} < 1.8V$	--	0.24	0.35		
		$1.8V \leq V_{OUT} < 2.1V$	--	0.2	0.3		
		$2.1V \leq V_{OUT} < 2.5V$	--	0.17	0.25		
		$2.5V \leq V_{OUT} < 3V$	--	0.16	0.23		
		$3V \leq V_{OUT}$	--	0.15	0.2		
Current Limit	I_{LIM}	$V_{OUT} = 90\%$ of $V_{OUT(NOM)}$	450			mA	
Short Circuit Current	I_{SC}	$V_{OUT} = 0V$		45		mA	
Quiescent Current	I_Q	$I_{LOAD} = 0mA$, $V_{OUT} \leq 4.5V$ $V_{IN} \geq V_{OUT} + V_{DROP}$	--	1.3	2.5	μA	
Shutdown Current	I_{SHDN}	$V_{EN} = 0V$, $V_{IN} = 5V$	--	0.08	0.5	μA	
EN Threshold Voltage	H-Level	V_{ENH}	$V_{IN} = 5V$	0.9		V	
	L-Level	V_{ENL}	$V_{IN} = 5V$			0.4 V	
EN Input Current	I_{EN}	$V_{EN} = 5.5V$	--	0.1	0.5	μA	
Line Regulation	$\Delta LINE$	$I_{LOAD} = 1mA$	--	0.02	0.5	%	
Load Regulation	$\Delta LOAD$	$I_{LOAD} = 1mA$ to 350mA	--	20	50	mV	
Power Supply Ripple Rejection	PSRR	$V_{IN}=3V$, $I_{LOAD} = 60mA$, $V_{OUT} = 1.8V$ $C_{OUT} = 1\mu F$, $f=1kHz$	--	85	--	dB	
Output Voltage Noise	eN	$V_{IN}=2.8V$, $I_{LOAD} = 30mA$, $V_{OUT} = 1.8V$ BW= 10Hz to 100 kHz		30		μV_{rms}	
Thermal Shutdown Temperature	T_{SD}	$I_{LOAD} = 5mA$, $V_{IN} \geq 1.5V$	--	160	--	$^{\circ}C$	
Thermal Shutdown Hysteresis	ΔT_{SD}		--	30	--	$^{\circ}C$	
Discharge Resistance	R_{Dis}	$EN = 0V$, $V_{OUT} = 0.1V$	--	10	--	Ω	

Typical Application Circuit

Fixed Mode

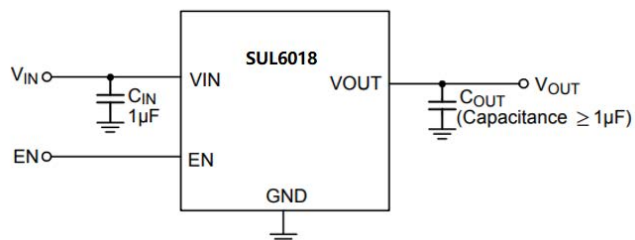

ADJ Mode

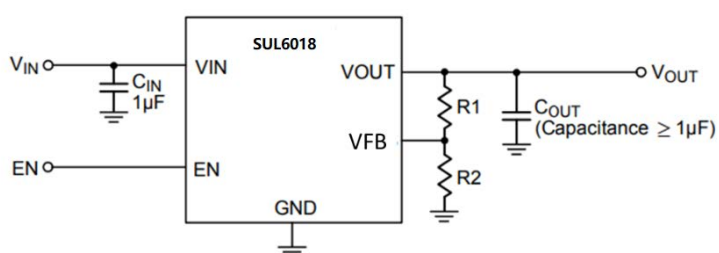

Functional Block Diagram

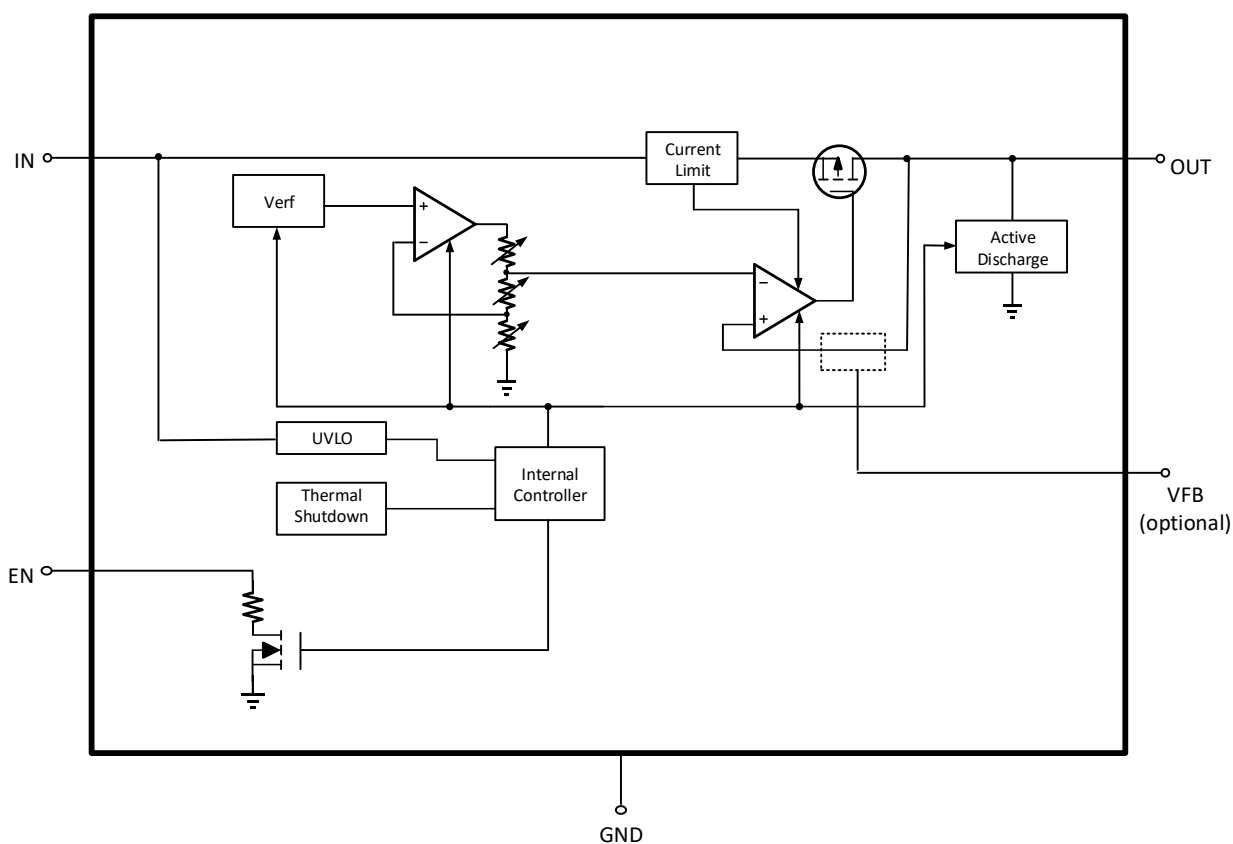

TYPICAL CHARACTERISTICS

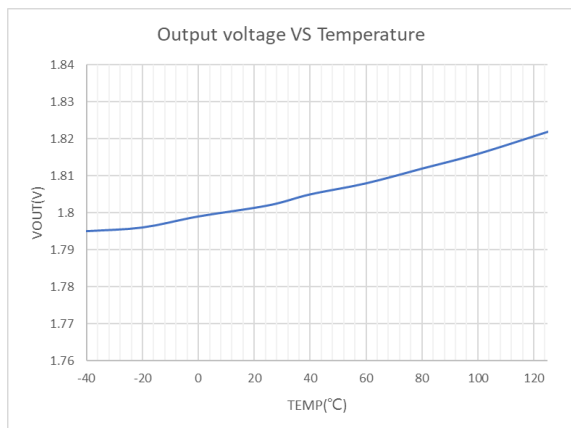

VOUT=1.8V, IOU=1mA

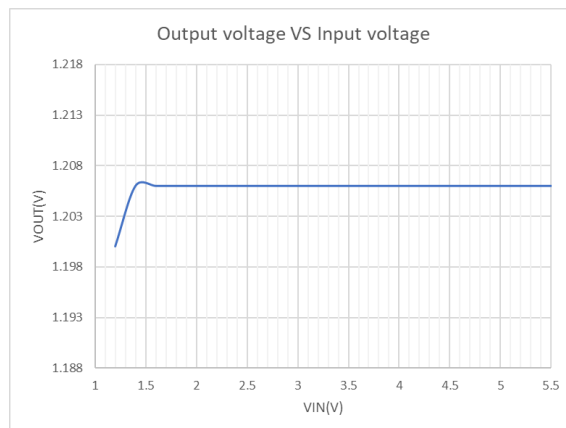

VOUT=1.2V, IOU=1mA

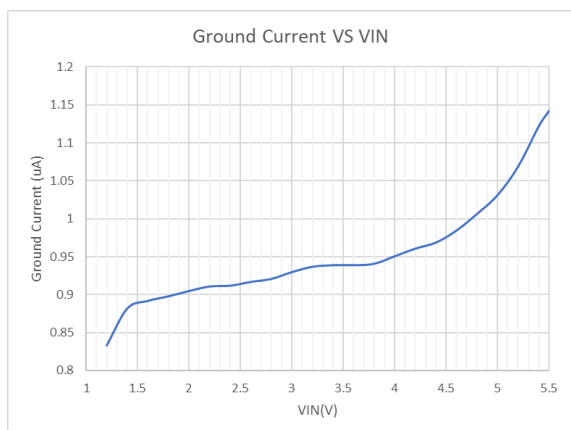

VOUT=0.8V

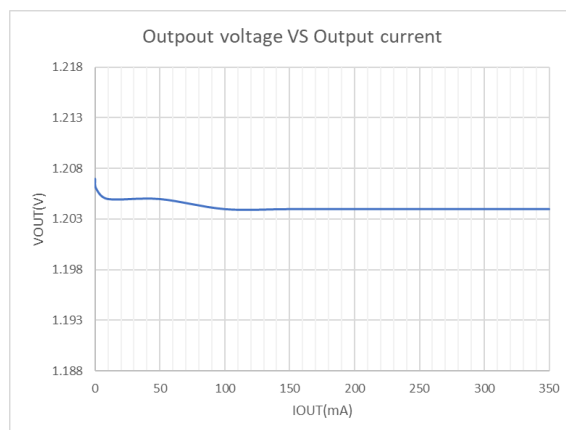

VOUT=1.2V

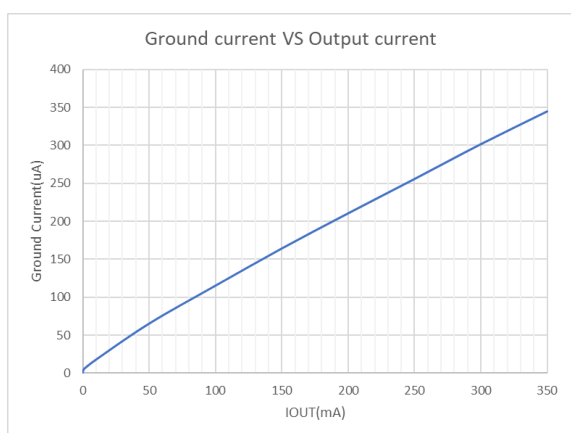

VOUT=1.2V

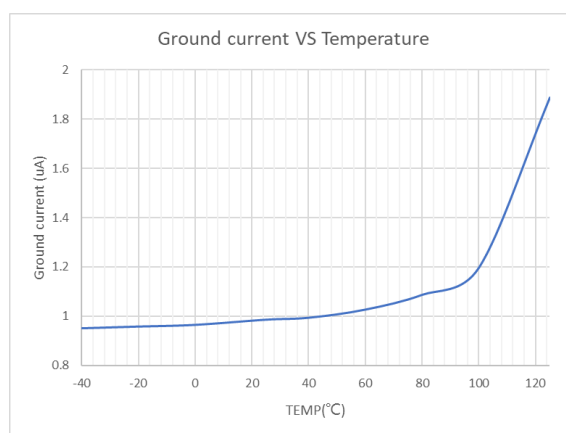

VOUT=1.2V

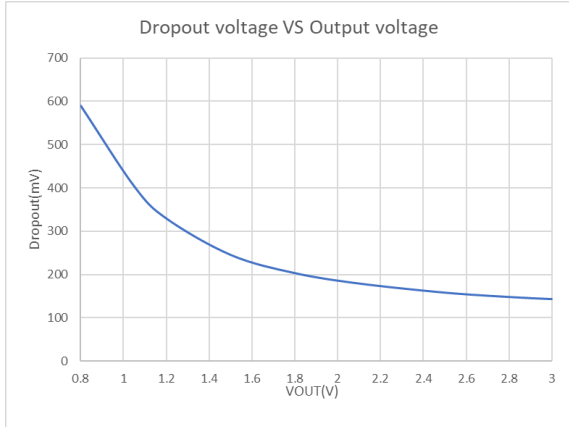

IOUT=300mA

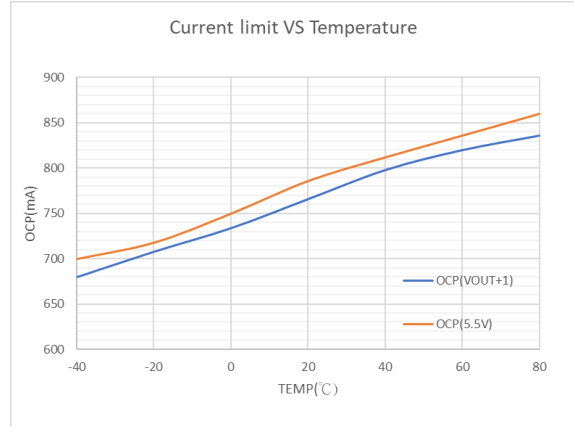

VOUT=1.2V

Power On From VIN

Ch1:VIN Ch3:VOUT Ch4:IOUT

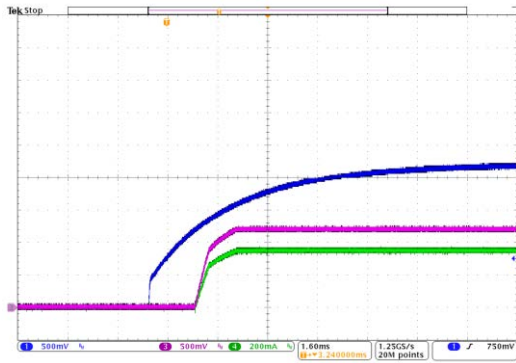

Power Off From VIN

Ch1:VIN Ch3:VOUT Ch4:IOUT

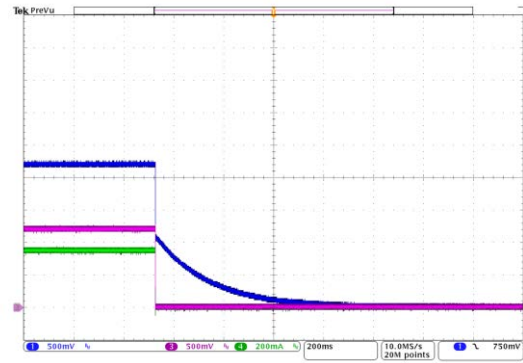

Power On From EN

Ch1:VIN Ch2:EN Ch3:VOUT Ch4:IOUT

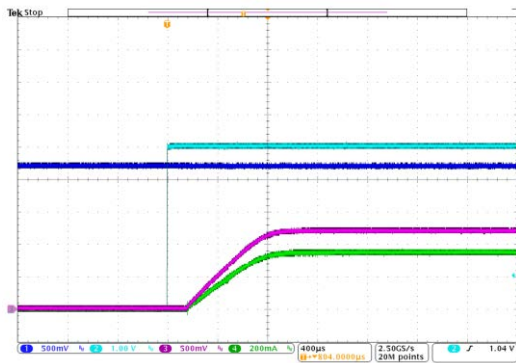

Power Off From EN

Ch1:VIN Ch2:EN Ch3:VOUT Ch4:IOUT

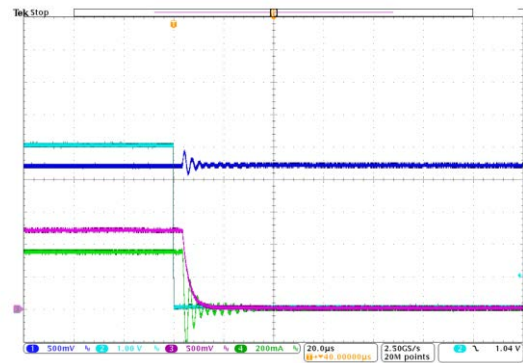

Line Transient Response

VIN=2.2V to 3.2V, IOUT=1mA

Ch1:VIN Ch3:VOUT

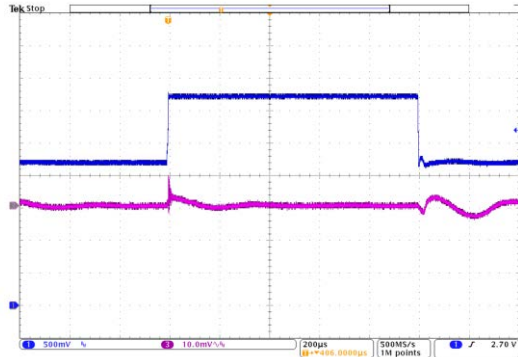

Load Transient Response

IOUT=1mA to 350mA

Ch1:VIN Ch3:VOUT Ch4:IOUT

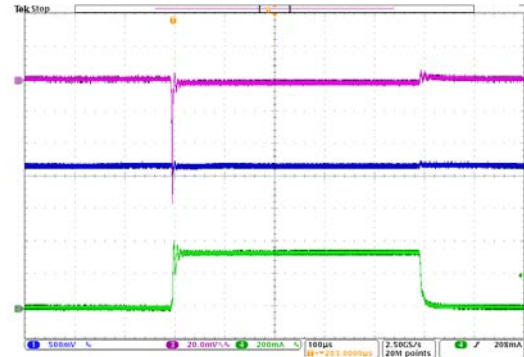

Over Current Protection

Ch1:VIN Ch3:VOUT Ch4:IOUT

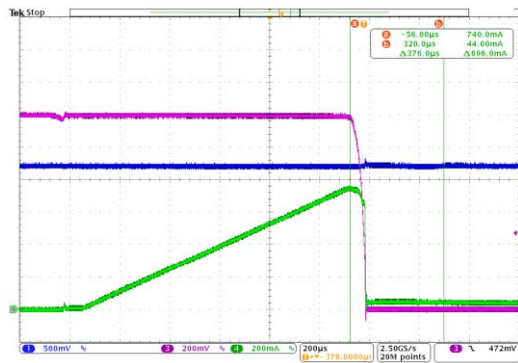

Output Short Protect

Ch1:VIN Ch3:VOUT Ch4:IOUT

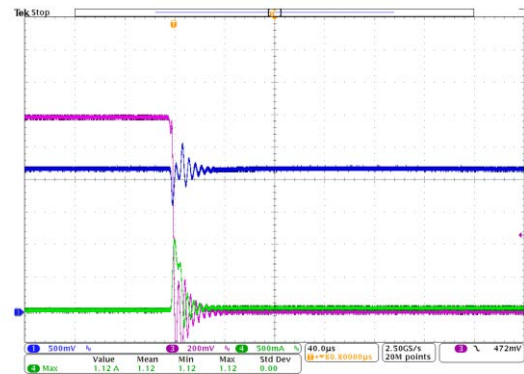

PSRR vs. Frequency

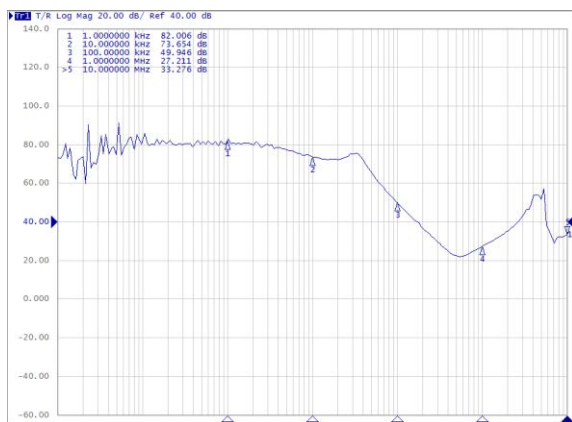

Output Noise vs. Frequency

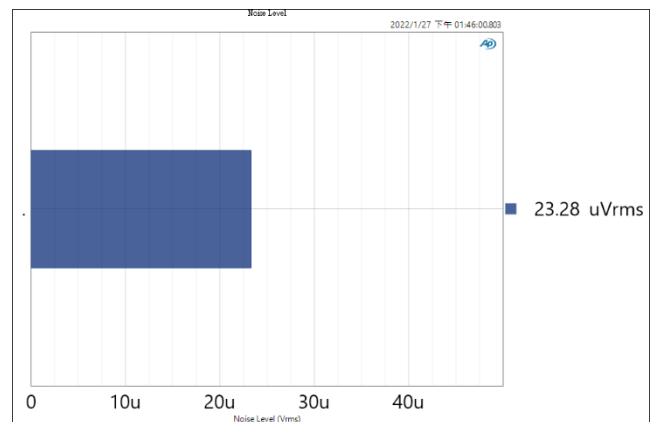

PACKAGE OUTLINE

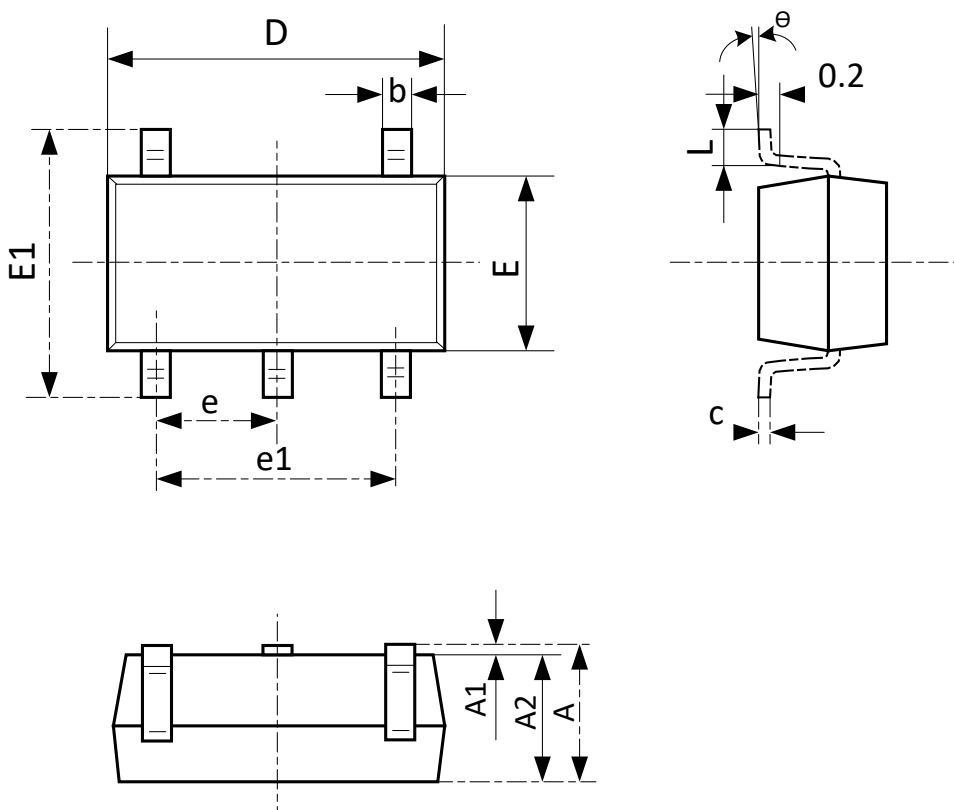
Package	SOT23-5L	Devices per reel	3000Pcs	Unit	mm
Package Dimension:					
					
Symbol	Dimensions In Millimeters		Dimensions In Inches		
	Min	Max	Min	Max	
A	1.050	1.250	0.041	0.049	
A1	0.000	0.100	0.000	0.004	
A2	1.050	1.150	0.041	0.045	
b	0.300	0.500	0.012	0.020	
c	0.100	0.200	0.004	0.008	
D	2.820	3.020	0.111	0.119	
E	1.500	1.700	0.059	0.067	
E1	2.650	2.950	0.104	0.116	
e	0.950(BSC)		0.037(BSC)		
e1	1.800	2.000	0.071	0.079	
L	0.300	0.600	0.012	0.024	
θ	0°	8°	0°	8°	

PACKAGE OUTLINE

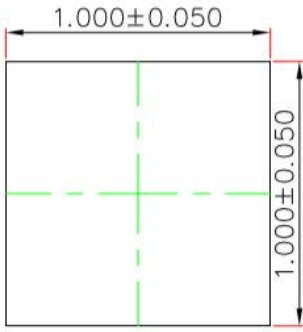
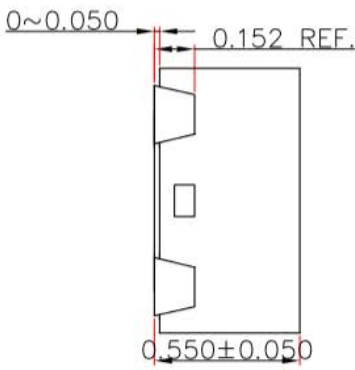
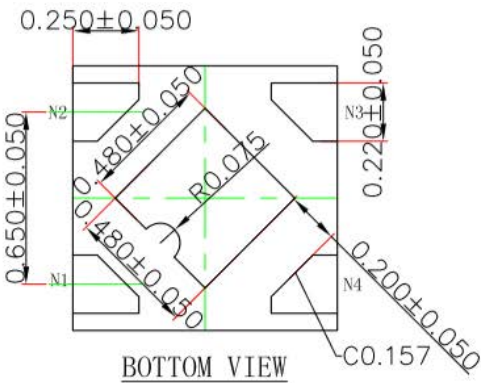
Package	DFN1x1-4L	Devices per reel	10000Pcs	Unit	mm
Package Dimension #1:					
 <p style="text-align: center;"><u>TOP VIEW</u></p>		 <p style="text-align: center;"><u>SIDE VIEW</u></p>			
 <p style="text-align: center;"><u>BOTTOM VIEW</u></p>					

PACKAGE OUTLINE

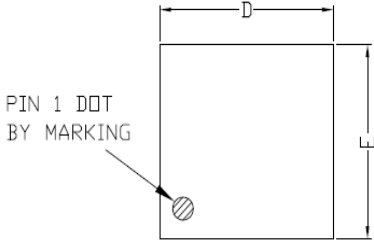
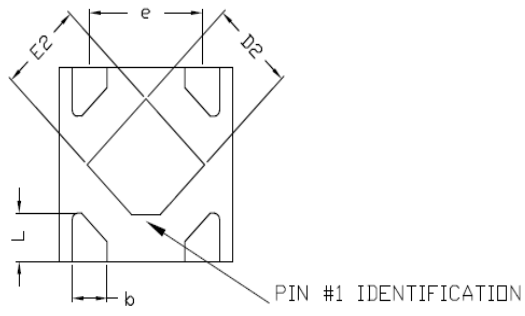
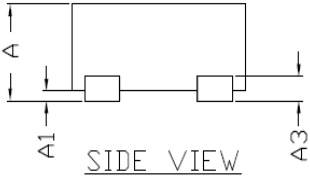
Package	DFN1x1-4L	Devices per reel	10000Pcs	Unit	mm																																																				
Package Dimension #2:																																																									
 <p>PIN 1 DOT BY MARKING</p> <p>TOP VIEW</p>		 <p>PIN #1 IDENTIFICATION CHAFMER 0.12MM</p> <p>BOTTOM VIEW</p>																																																							
 <p>SIDE VIEW</p>		<table border="1"> <thead> <tr> <th colspan="4">COMMON DIMENSIONS(MM)</th> </tr> <tr> <th>PKG.</th> <th colspan="3">X1:EXTREME THIN</th> </tr> <tr> <th>REF.</th> <th>MIN.</th> <th>NOM.</th> <th>MAX</th> </tr> </thead> <tbody> <tr> <td>A</td> <td>0.40</td> <td>-</td> <td>0.50</td> </tr> <tr> <td>A1</td> <td>0.00</td> <td>-</td> <td>0.05</td> </tr> <tr> <td>A3</td> <td colspan="3">0.125REF.</td> </tr> <tr> <td>D</td> <td>0.95</td> <td>1.00</td> <td>1.05</td> </tr> <tr> <td>E</td> <td>0.95</td> <td>1.00</td> <td>1.05</td> </tr> <tr> <td>b</td> <td>0.15</td> <td>0.20</td> <td>0.25</td> </tr> <tr> <td>L</td> <td>0.15</td> <td>0.25</td> <td>0.35</td> </tr> <tr> <td>D2</td> <td>0.38</td> <td>0.48</td> <td>0.58</td> </tr> <tr> <td>E2</td> <td>0.38</td> <td>0.48</td> <td>0.58</td> </tr> <tr> <td>e</td> <td colspan="3">0.65 BSC</td> </tr> </tbody> </table>				COMMON DIMENSIONS(MM)				PKG.	X1:EXTREME THIN			REF.	MIN.	NOM.	MAX	A	0.40	-	0.50	A1	0.00	-	0.05	A3	0.125REF.			D	0.95	1.00	1.05	E	0.95	1.00	1.05	b	0.15	0.20	0.25	L	0.15	0.25	0.35	D2	0.38	0.48	0.58	E2	0.38	0.48	0.58	e	0.65 BSC		
COMMON DIMENSIONS(MM)																																																									
PKG.	X1:EXTREME THIN																																																								
REF.	MIN.	NOM.	MAX																																																						
A	0.40	-	0.50																																																						
A1	0.00	-	0.05																																																						
A3	0.125REF.																																																								
D	0.95	1.00	1.05																																																						
E	0.95	1.00	1.05																																																						
b	0.15	0.20	0.25																																																						
L	0.15	0.25	0.35																																																						
D2	0.38	0.48	0.58																																																						
E2	0.38	0.48	0.58																																																						
e	0.65 BSC																																																								
REMARK: LEAD FINISH: NIPDAU																																																									