

■ PRODUCT CHARACTERISTICS

VDSS	500V
$R_{DS(on)Typ}(@V_{GS} = 10V)$	0.36Ω
Qg@type	33 nC
ID	15A

■ APPLICATIONS

- * High efficiency switch mode power supplies
- * Electronic lamp ballasts based on half bridge
- * LED power supplies

■ FEATURES

- * Fast switching capability
- * Avalanche energy specified
- * Improved dv/dt capability, high ruggedness

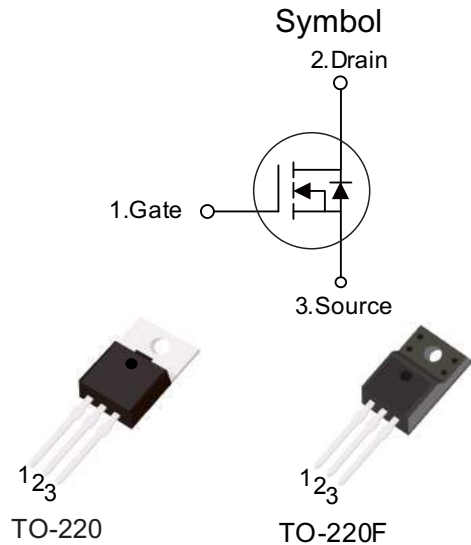

■ ORDER INFORMATION

Order codes		Package	Packing
Halogen-Free	Halogen		
N/A	MOT15N50HF	TO-220F	50 pieces/Tube
N/A	MOT15N50A	TO-220	50 pieces/Tube

■ ABSOLUTE MAXIMUM RATINGS ($T_C = 25^\circ\text{C}$, unless otherwise specified)

Parameter	Symbol	Ratings	Unit
Drain to Source Voltage	V_{DSS}	500	V
Gate to Source Voltage	V_{GSS}	± 30	V
Avalanche Current (Note 2)	I_{AR}	15	A
Continuous Drain Current	Continuous	I_D	15
	Pulsed (Note 2)	I_{DM}	60
Avalanche Energy	Single Pulsed (Note 3)	E_{AS}	637
	Repetitive (Note 2)	E_{AR}	25
Peak Diode Recovery dv/dt (Note 4)	dv/dt	4.5	V/ns
Power Dissipation	TO-220F	P_D	38.5
	TO-220AB		300
Junction Temperature	T_J	+150	$^\circ\text{C}$
Storage Temperature	T_{STG}	-55 ~ +150	$^\circ\text{C}$

Notes: 1. Absolute maximum ratings are those values beyond which the device could be permanently damaged.

Absolute maximum ratings are stress ratings only and functional device operation is not implied.

2. Repetitive Rating : Pulse width limited by maximum junction temperature

3. $L=5.23\text{mH}$, $I_{AS}=15\text{A}$, $V_{DD}=50\text{V}$, $R_G=25\Omega$, Starting $T_J=25^\circ\text{C}$

4. $I_{SD} \leq 15\text{A}$, $di/dt \leq 200\text{A}/\mu\text{s}$, $V_{DD} \leq BV_{DSS}$, Starting $T_J=25^\circ\text{C}$

■ ELECTRICAL CHARACTERISTICS ($T_C=25^{\circ}\text{C}$, unless otherwise noted)

Parameter	Symbol	Test conditions	Min	Typ	Max	Units
Static						
Drain to Source Breakdown Voltage	B_{VDSS}	$I_D = 250\mu\text{A}$, $V_{GS} = 0\text{V}$	500	-	-	V
Breakdown Voltage Temp. Coefficient	$\Delta B_{VDSS}/\Delta T_J$	Reference to 25°C , $I_D = 1\text{mA}$	-	0.58	-	$\text{V}/^{\circ}\text{C}$
Drain to Source On-Resistance	$r_{DS(ON)}$	$V_{GS} = 10\text{V}$, $I_D = 7.5\text{A}$	-	0.36	0.40	Ω
Gate Threshold Voltage	$V_{GS(th)}$	$V_{DS} = V_{GS}$, $I_D = 250\mu\text{A}$	2.0	3.4	4.0	V
Zero Gate Voltage Drain Current	I_{DSS}	$V_{DS} = 500\text{V}$, $V_{GS} = 0\text{V}$	-	-	1	μA
			-	-	250	μA
Gate to Source Leakage Current	I_{GSS}	$V_{GS} = \pm 30\text{V}$	-	-	± 100	nA
Dynamics						
Forward Transconductance	g_{fs}	$V_{DD} = 10\text{V}$, $I_D = 7.5\text{A}$	10	-	-	S
Total Gate Charge at 10V	$Q_{g(TOT)}$	$V_{GS} = 10\text{V}$, $V_{DS} = 400\text{V}$, $I_D = 15\text{A}$	-	33	41	nC
Gate to Source Gate Charge	Q_{gs}		-	7.2	10	nC
Gate to Drain "Miller" Charge	Q_{gd}		-	12	16	nC
Turn-On Delay Time	$t_{d(ON)}$		-	9	-	ns
Rise Time	t_r	$V_{DD} = 250\text{V}$, $I_D = 15\text{A}$, $R_G = 6.2\Omega$, $R_D = 17\Omega$	-	5.4	-	ns
Turn-Off Delay Time	$t_{d(OFF)}$		-	26	-	ns
Fall Time	t_f		-	5	-	ns
Input Capacitance	C_{ISS}	$V_{DS} = 25\text{V}$, $V_{GS} = 0\text{V}$, $f = 1\text{MHz}$	-	1850	-	pF
Output Capacitance	C_{OSS}		-	230	-	pF
Reverse Transfer Capacitance	C_{RSS}		-	16	-	pF
Avalanche characteristics						
Single Pulse Avalanche Energy ²	E_{AS}		760	-	-	mJ
Avalanche Current	I_{AR}		-	-	15	A
Drain-source diode characteristics						
Continuous Source Current (Body Diode)	I_S		-	-	15	A
Pulsed Source Current ¹ (Body Diode)	I_{SM}		-	-	60	A
Source to Drain Diode Voltage	V_{SD}	$I_{SD} = 15\text{A}$	-	0.86	1.2	V
Reverse Recovery Time	t_{rr}	$I_{SD} = 15\text{A}$, $di_{SD}/dt = 100\text{A}/\mu\text{s}$	-	470	730	ns
Reverse Recovered Charge	Q_{RR}	$I_{SD} = 15\text{A}$, $di_{SD}/dt = 100\text{A}/\mu\text{s}$	-	5	6.6	μC

Notes:

- 1: Repetitive rating; pulse width limited by maximum junction temperature
- 2: Starting $T_J = 25^{\circ}\text{C}$, $L = 7.0\text{mH}$, $I_{AS} = 15\text{A}$

■ TEST CIRCUITS AND WAVEFORMS

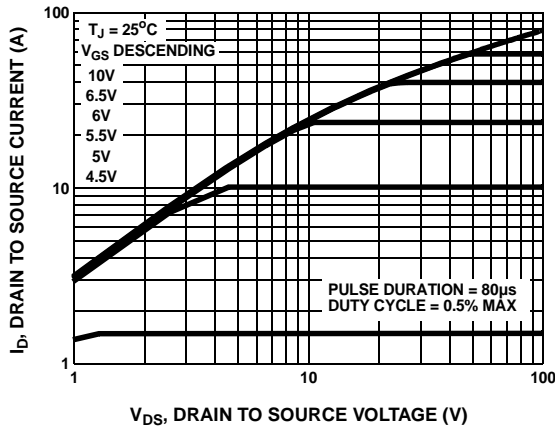

Figure 1. Output Characteristics

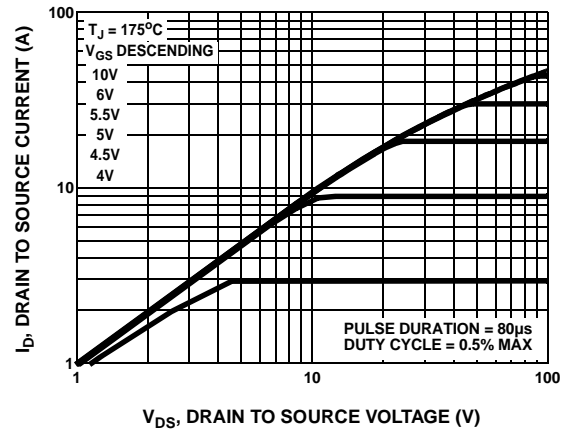

Figure 2. Output Characteristics

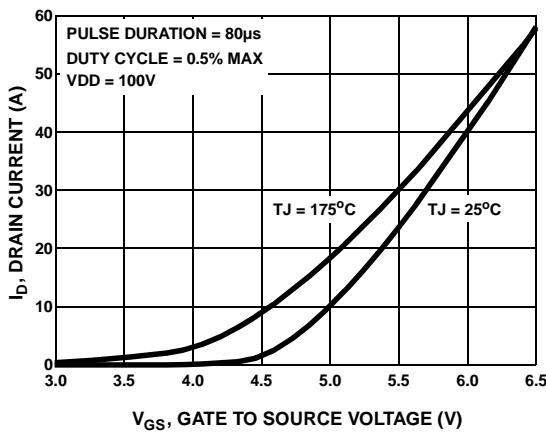

Figure 3. Transfer Characteristics

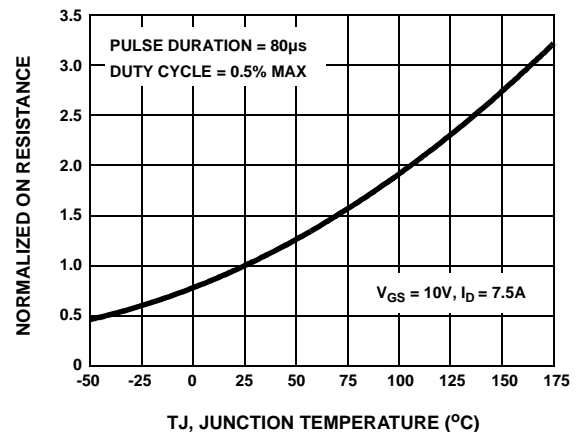

Figure 4. Normalized Drain To Source On Resistance vs Junction Temperature

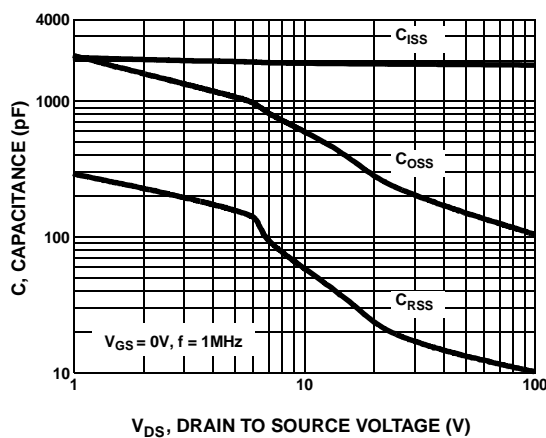

Figure 5. Capacitance vs Drain To Source Voltage

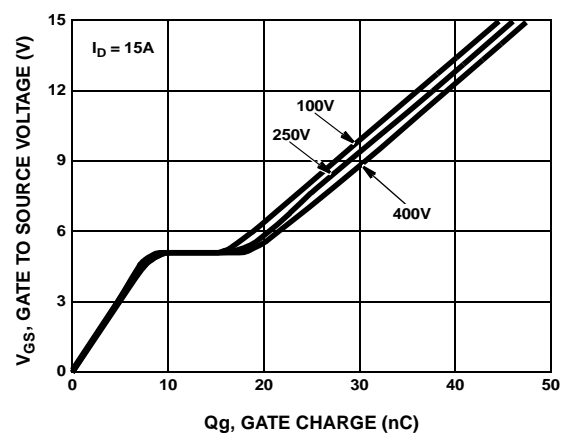

Figure 6. Gate Charge Waveforms For Constant Gate Current

■ TYPICAL CHARACTERISTICS

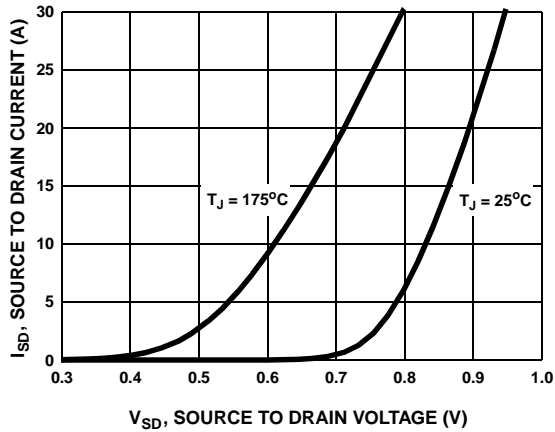

Figure 7. Body Diode Forward Voltage vs Body Diode Current

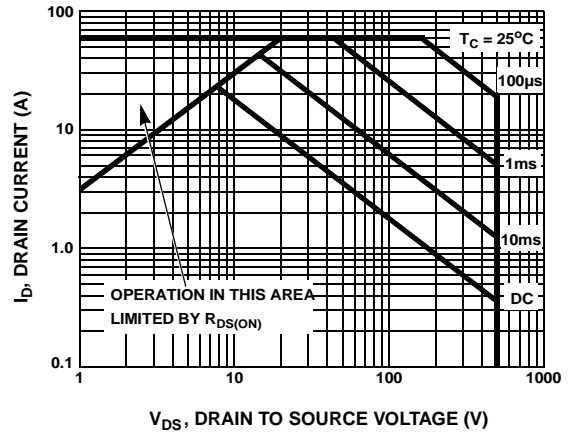

Figure 8. Maximum Safe Operating Area

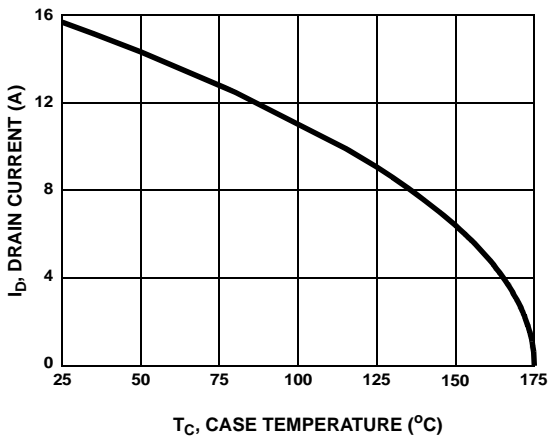

Figure 9. Maximum Drain Current vs Case Temperature

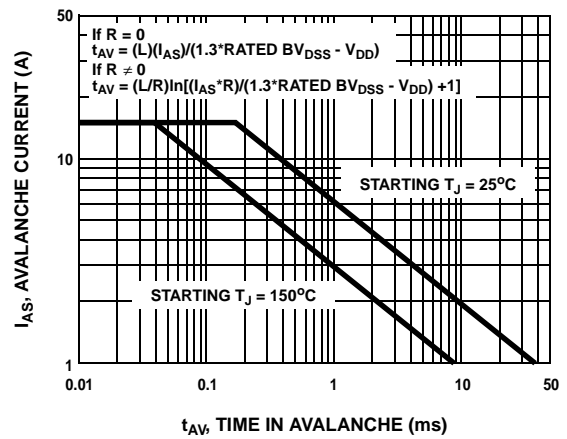
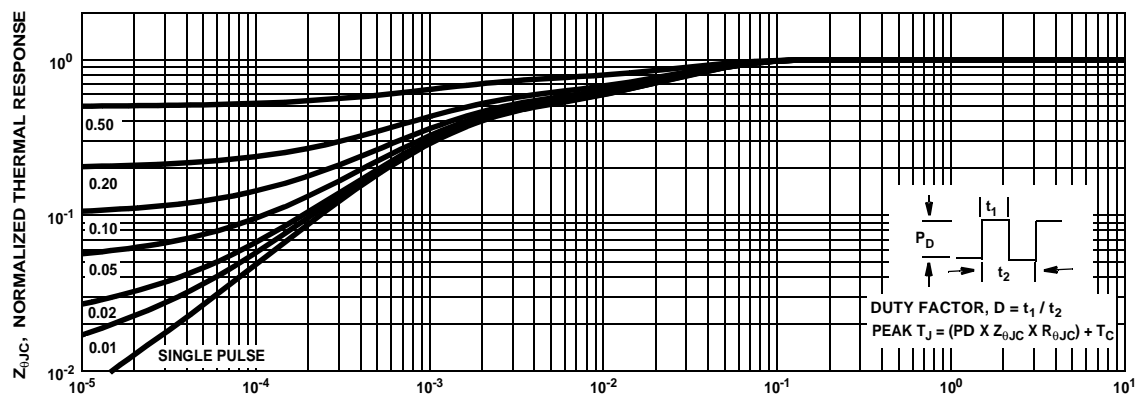
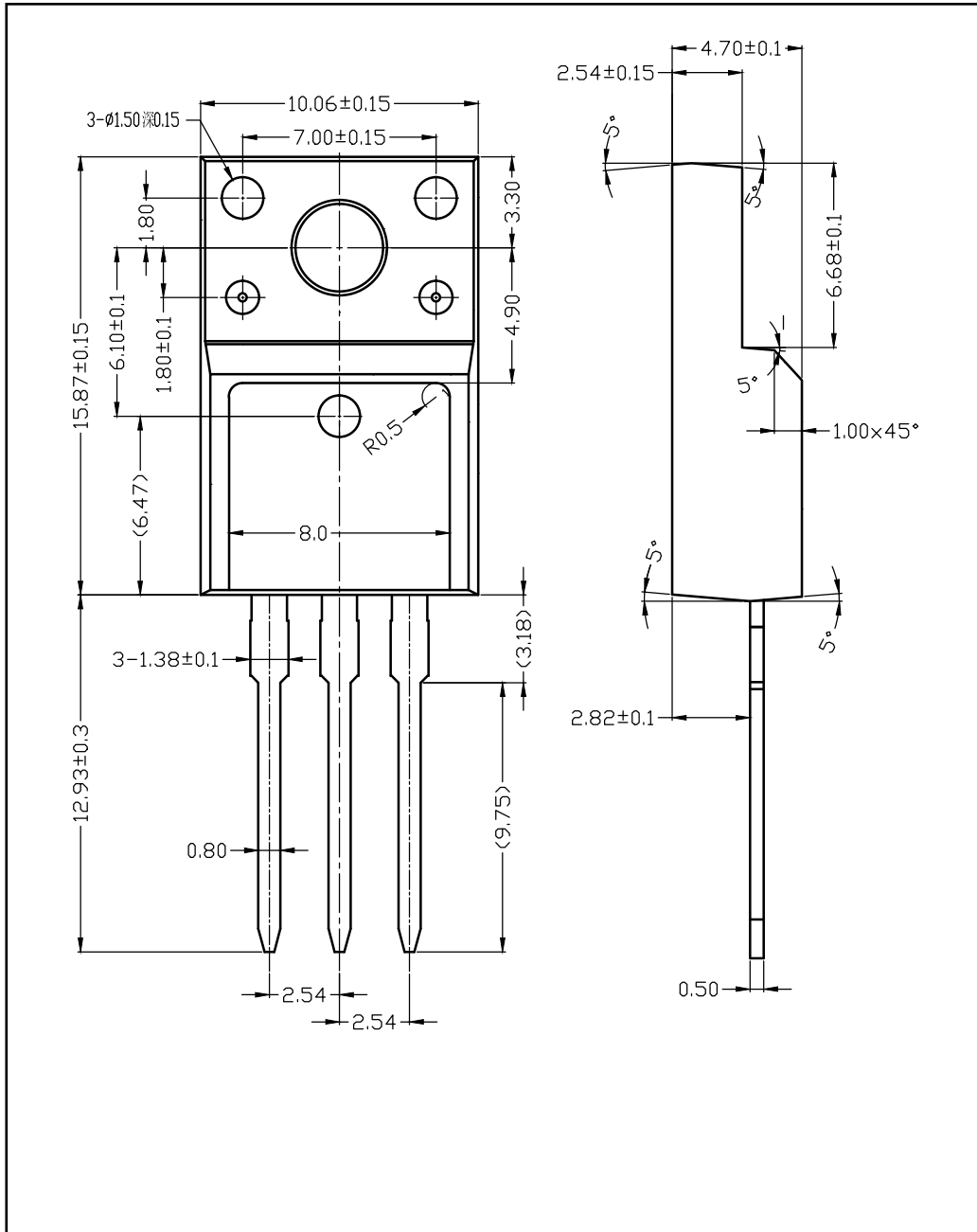

Figure 10. Unclamped Inductive Switching Capability



■ TO-220F PACKAGE OUTLINE DIMENSIONS



■ TO-220 PACKAGE OUTLINE DIMENSIONS

