

Features

- The plastic package carries Underwriters Laboratory Flammability Classification 94V-0
- Idea for printed circuit board
- Metal-Silicon junction chip
- Low reverse leakage
- High forward surge current capability
- High temperature soldering guaranteed
250°C/10 seconds at terminals

Mechanical Data

Case : Molded plastic body

Terminals : Solder plated, solderable per MIL-STD-750, Method 2026

Polarity : Polarity symbol marking on body

Mounting Position : Any

Package outline

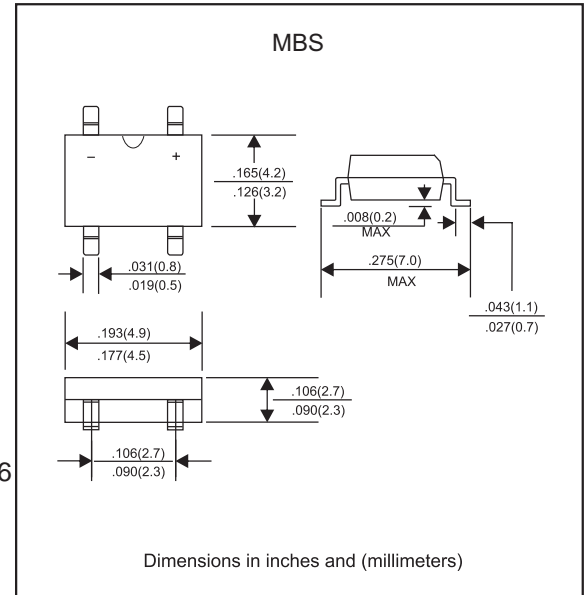

Maximum Ratings And Electrical Characteristics

Ratings at 25°C ambient temperature unless otherwise specified. Single phase half-wave 60Hz, resistive or inductive load, for capacitive load current derate by 20%.

Parameter	SYMBOLS	KMB 22S	KMB 24S	KMB 26S	KMB 28S	KMB 210S	KMB 215S	KMB 220S	UNITS
Maximum repetitive peak reverse voltage	V_{RRM}	20	40	60	80	100	150	200	V
Maximum RMS voltage	V_{RMS}	14	28	42	56	70	70	140	V
Maximum DC blocking voltage	V_{DC}	20	40	60	80	100	150	200	V
Maximum average forward rectified current at $T_L=100^\circ\text{C}$ On glass-epoxy P.C.B (Note 1)	$I_{(AV)}$	2.0							A
Peak forward surge current, 8.3ms single half sine-wave superimposed on rated load	I_{FSM}	50.0							A
Rating for fusing ($t=8.3\text{ms}$, $T_a=25^\circ\text{C}$)	I_t^2	10.37							A_s^2
Maximum instantaneous forward voltage at 2.0A	V_F	0.55	0.7	0.85	0.95				V
Maximum DC reverse current at rated DC blocking voltage $T_A=25^\circ\text{C}$ $T_A=125^\circ\text{C}$	I_R	0.5 50			0.2 20			mA	
Typical thermal resistance	R_{QA}	85.0							$^\circ\text{C}/\text{W}$
Operating junction temperature range	T_J	-55 to +125			-55 to +150				$^\circ\text{C}$
Storage temperature range	T_{STG}	-55 to +150							$^\circ\text{C}$

Note:1. Mounted on glass epoxy PC board with 1.3*1.3mm solder pad

Ratings And Characteristic Curves

FIG. 1- DERATING CURVE OUTPUT RECTIFIED CURRENT

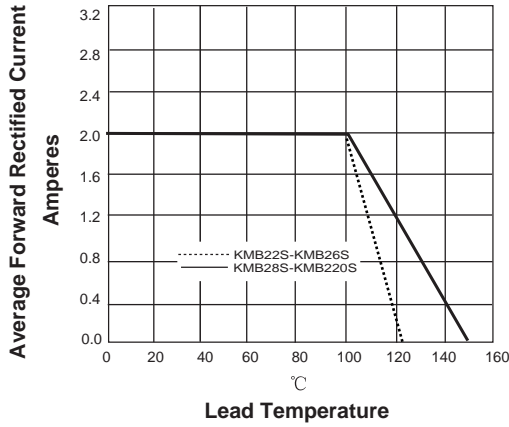

FIG. 2-MAXIMUM NON-REPETITIVE PEAK FORWARD SURGE CURRENT PER LEG

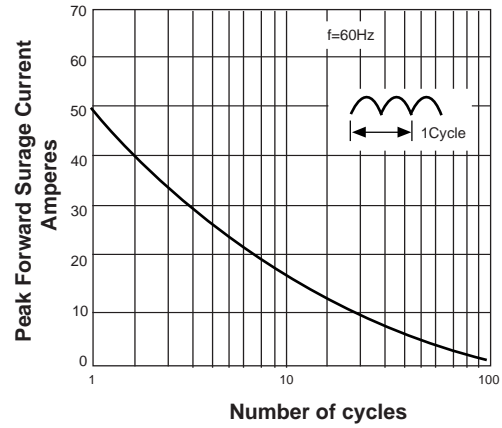

FIG. 3-TYPICAL FORWARD VOLTAGE CHARACTERISTICS

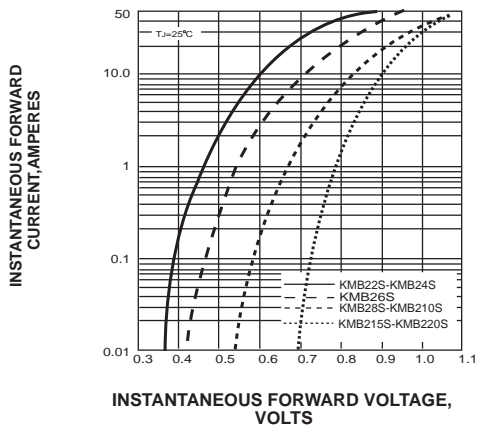
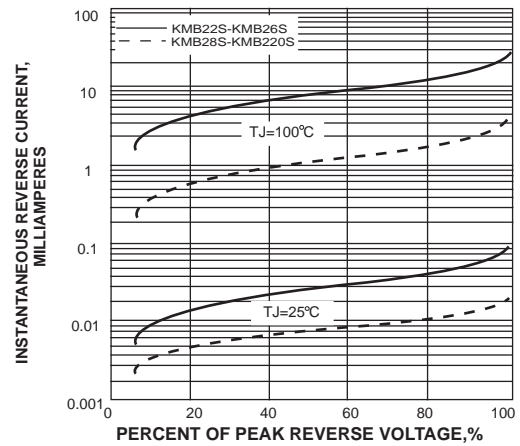
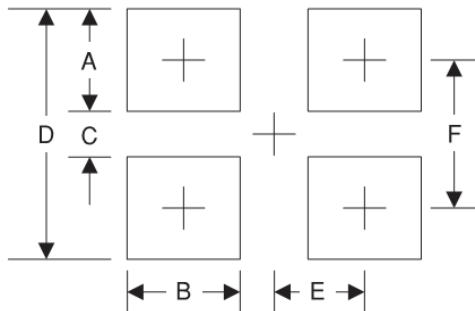

FIG. 4-TYPICAL REVERSE LEAKAGE CHARACTERISTICS



Suggested Pad Layout



Symbol	Unit (mm)	Unit (inch)
A	1.7	0.067
B	1.0	0.039
C	4.40	0.173
D	8.10	0.319
E	1.25	0.049
F	6.30	0.248