

Parameter	Specification
TE Part Number	CFS60383P-30NF
Frequency	600-960MHz 1350-1550MHz 1690-2700MHz 3300-3800MHz
Peak Gain (Average/Max) (dBi)	2.9/3.5 @600-698MHz 3.3/3.6 @698-806MHz 3.5/3.6 @824-894MHz 4.6/5.4 @880-960MHz 4.1/5.2 @1350-1550MHz 3.9/4.4 @1690-1880MHz 3.8/4.1 @1850-1990MHz 4.6/5.3 @1910-2180MHz 5.8/6.3 @2300-2500MHz 6.8/7.1 @2500-2700MHz 4.1/4.4 @3300-3800MHz
Polarization	Horizontal
VSWR (Typical/Max :1)	<1.8/<1.8 @600-698MHz <1.5/<1.8 @698-806MHz <1.6/<1.8 @824-894MHz <1.6/<1.8 @880-960MHz <1.7/<1.8 @1350-1550MHz <1.8/<1.8 @1690-1880MHz <1.4/<1.8 @1850-1990MHz <1.4/<1.8 @1910-2180MHz <1.5/<1.8 @2300-2500MHz <1.4/<1.8 @2500-2700MHz <1.7/<2.0 @3300-3800MHz
PIM (3rd Order, 2x20W), Typical	<-156dBc (600-960MHz) <-157dBc (1690-2180MHz)
PIM (3rd Order, 2x20W), Max	<-150dBc (600-960MHz;1690-2180MHz)
Azimuth Beam Width	360°, Omnidirectional
Max Power (Ambient 25°C/77°F)	50W
Weight	181g(0.4lbs) without mounting kit
Radome	PC, UL94-V0
Color	White
Operating Temperature	-30°C ~ +70°C
Storage Temperature	-40°C ~ +85°C
RoHS Compliance	Yes
RF Connector	Type N, Female
Cable Length	304.8mm(1ft)
Antenna Dimension (WxLxH)	117.2mmx180.3mmx7.6mm

F03

F03

F03

F02

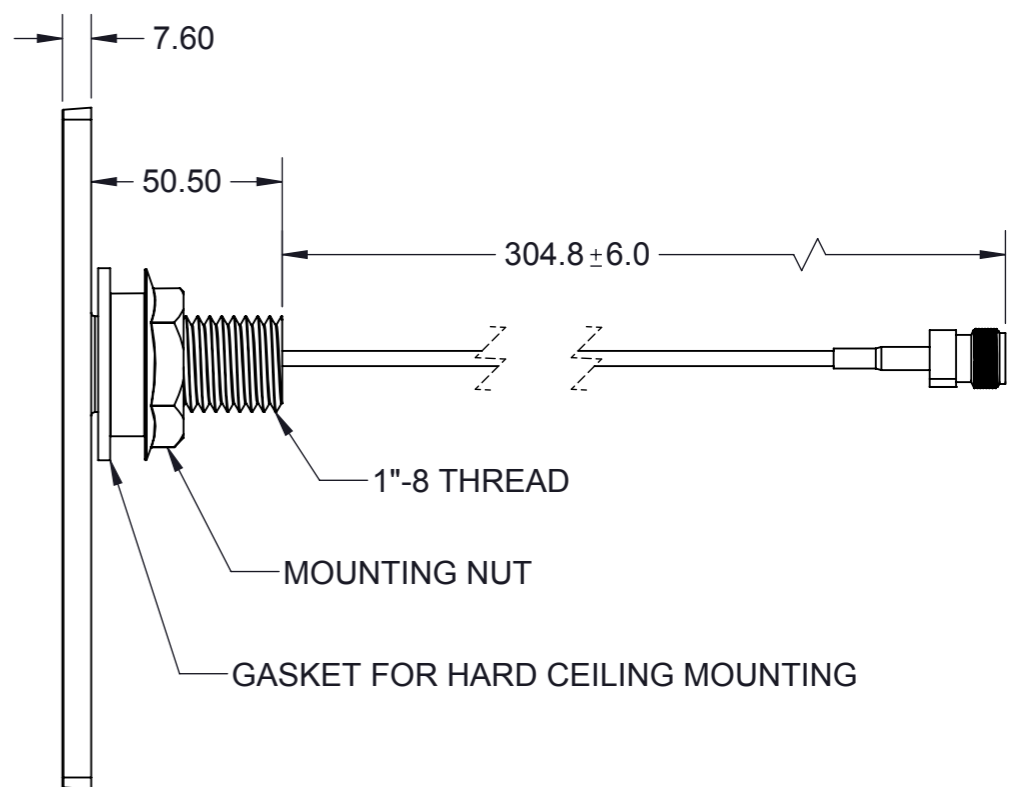
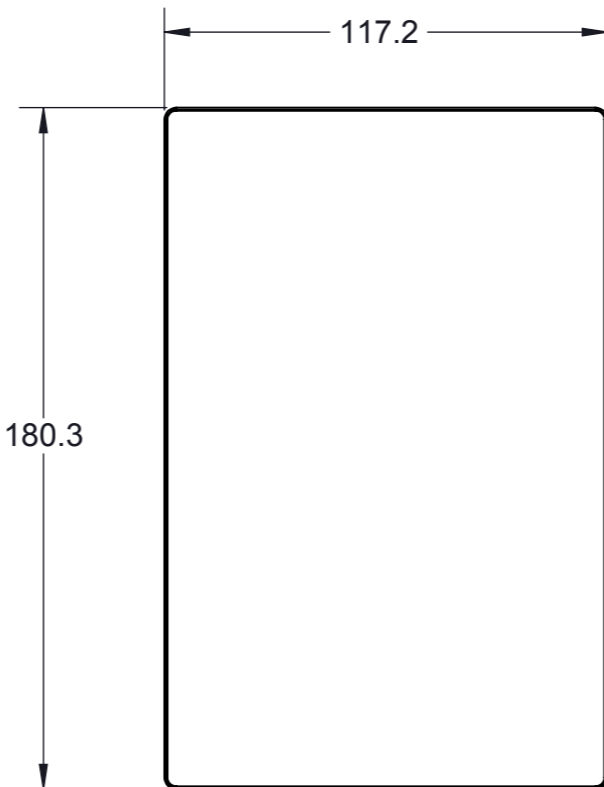

REVISIONS					
REV.	ECN#	ZONE	DESCRIPTION	CHANGED BY/DATE	APPROVED BY/DATE
F01	ECN-IAS-05333		NEW RELEASE	CYH / 04MAY16	WTN / 04MAY16
F02	ECN-IAS-05523		UPDATE PEAK GAIN AND VSWR; CHANGE HOUSING MATERIAL FROM PC+ABS TO PC	CYH / 17JUN16	WTN / 17JUN16
F03	ECN-IAS-05942		UPDATE GAIN SPECIFICATION; ADD IN TYPICAL VSWR AND PIM VALUE	CYH / 29NOV16	WTN / 29NOV16

MATERIAL:		THIRD ANGLE PROJECTION			
FINISH:		DO NOT SCALE DRAWING			
APPROVALS		DATE		CFS60383P-30NF	
DRAWN BY	CY HANG	29APR16			
ELEC. ENG.	KJ NG	29APR16			
MECH. ENG.	CY HANG	29APR16			
MFG./OPS.		29APR16		TITLE: CFS60383P-30NF	
THIS DRAWING IS UNPUBLISHED.		RELEASED FOR PUBLICATION		DWG. NO. CFS60383P-30NFMO	
© Copyright 2022 TE Connectivity Ltd.		ALL RIGHTS RESERVED.		REV F03	
				SCALE: 1:5 PREVIOUS#	
				SHEET 1 OF 1	