

Verpackt im Gurt in Anlehnung an DIN IEC 60286-3
 tape on reel packaging according to DIN IEC 60286-3
 Verpackungseinheit: 170 Stück
 packaging unit: 170 pcs

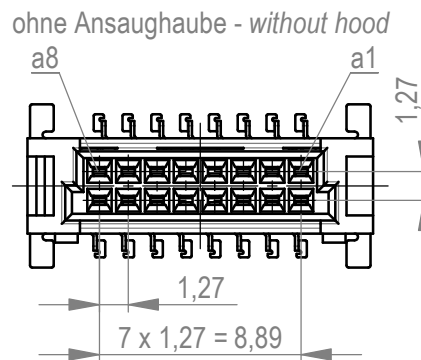

Abspulrichtung - reel off direction

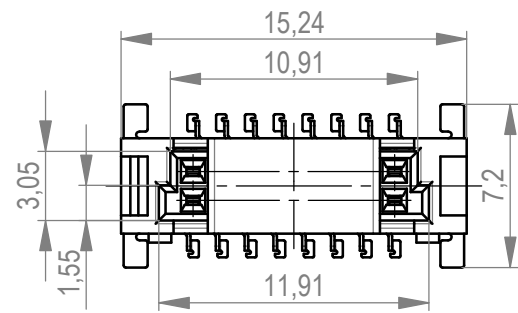
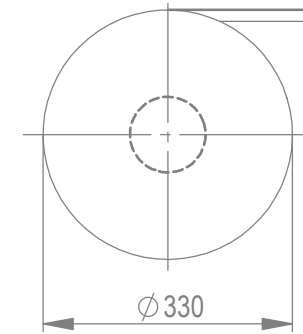
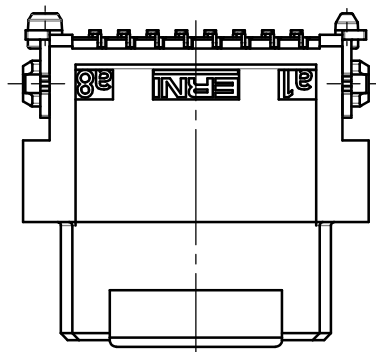
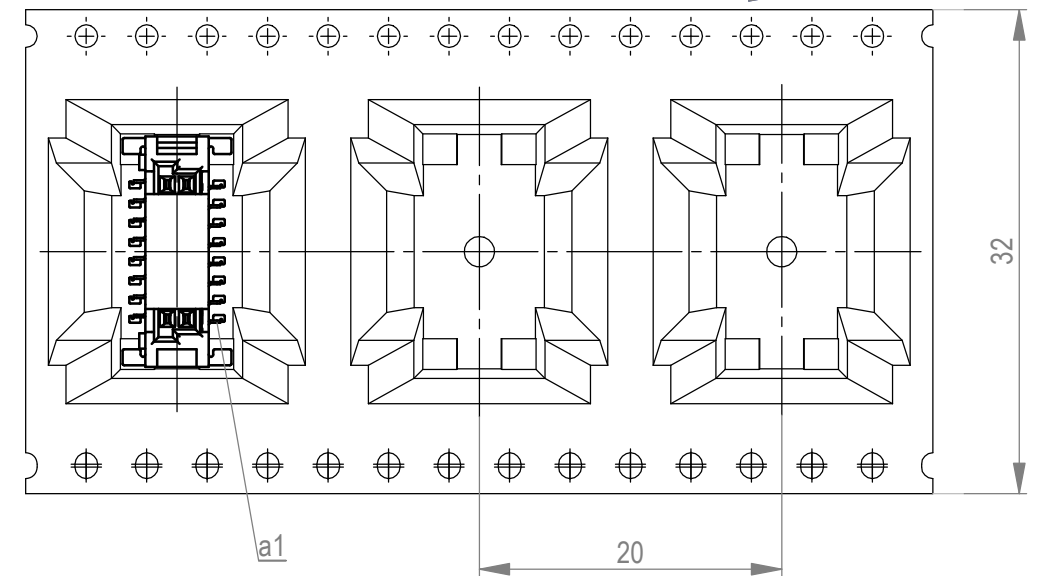

Anforderungsstufe 1
 performance level 1

Kontaktbereich vergoldet
 mating area gold plating

Anschlussbereich verzinkt 4-6 µm
 terminal area 4-6 µm tin plating

Koplanarität der Anschlüsse ≤ 0,1 mm
 coplanarity area of termination ≤ 0,1 mm

Leiterplatten-Layout Vorschlag für SMT
 PCB-Layout Proposal for SMT

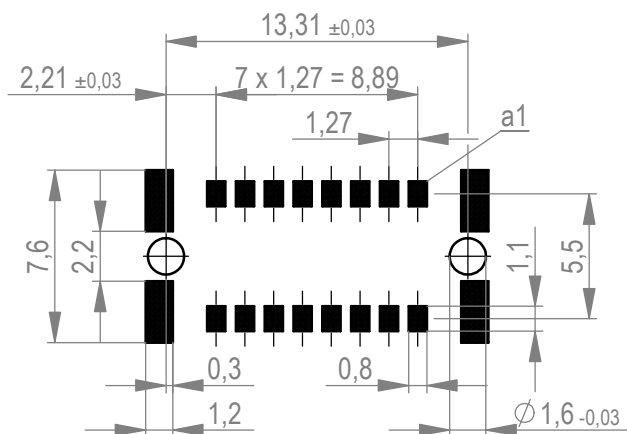

BA 7-23 - hohe Bauhöhe
 type 7-23 - high profile

Weitergabe sowie Vervielfältigung dieses Dokuments, Verwertung und Mitteilung seines Inhalts sind verboten, soweit nicht ausdrücklich gestattet. Zuwiderhandlungen verpflichten zu Schadenersatz. Alle Rechte für den Fall der Patent-, Gebrauchsmuster- oder Geschmacksmusterertragung vorbehalten. The reproduction, distribution and utilization of this document as well as the communication of its contents to others without express authorization is prohibited. Offenders will be held liable for the payment of damages. All rights reserved in the event of the grant of a patent, utility model or design.

Die deutsche Version dieser Zeichnung dient nur zur Erleichterung der Handhabung. Bei Abweichungen von dem englischen Original gilt das englische Original. The german version of this drawing has been offered for convenience only and may deviate from the english original. In case of any deviation the English version shall prevail.

Dimension no.	Tolerances	All Dimensions in mm	Scale 5:1
	ISO 8015		Material
Customer drawing:	Subject to modification without prior notice. Drawing will not be updated.		Federl. SMC-B 16-SMD-BA7-23 Female SMC-B 16-SMT-type7-23 C-354070-E
This Drawing is a controlled Document.			
d1	12.05.2023		c
Index	Date		A3
Class			SMCB