

REVISIONS ÄNDERUNGEN DESCRIPTION BESCHREIBUNG				
P	LTR	DATE	DWN	APVD
	E1	NOTE 1 0.76µm PLATING UPDATE (PdNi+AuFLASH)	14JUL2023	BGC PS

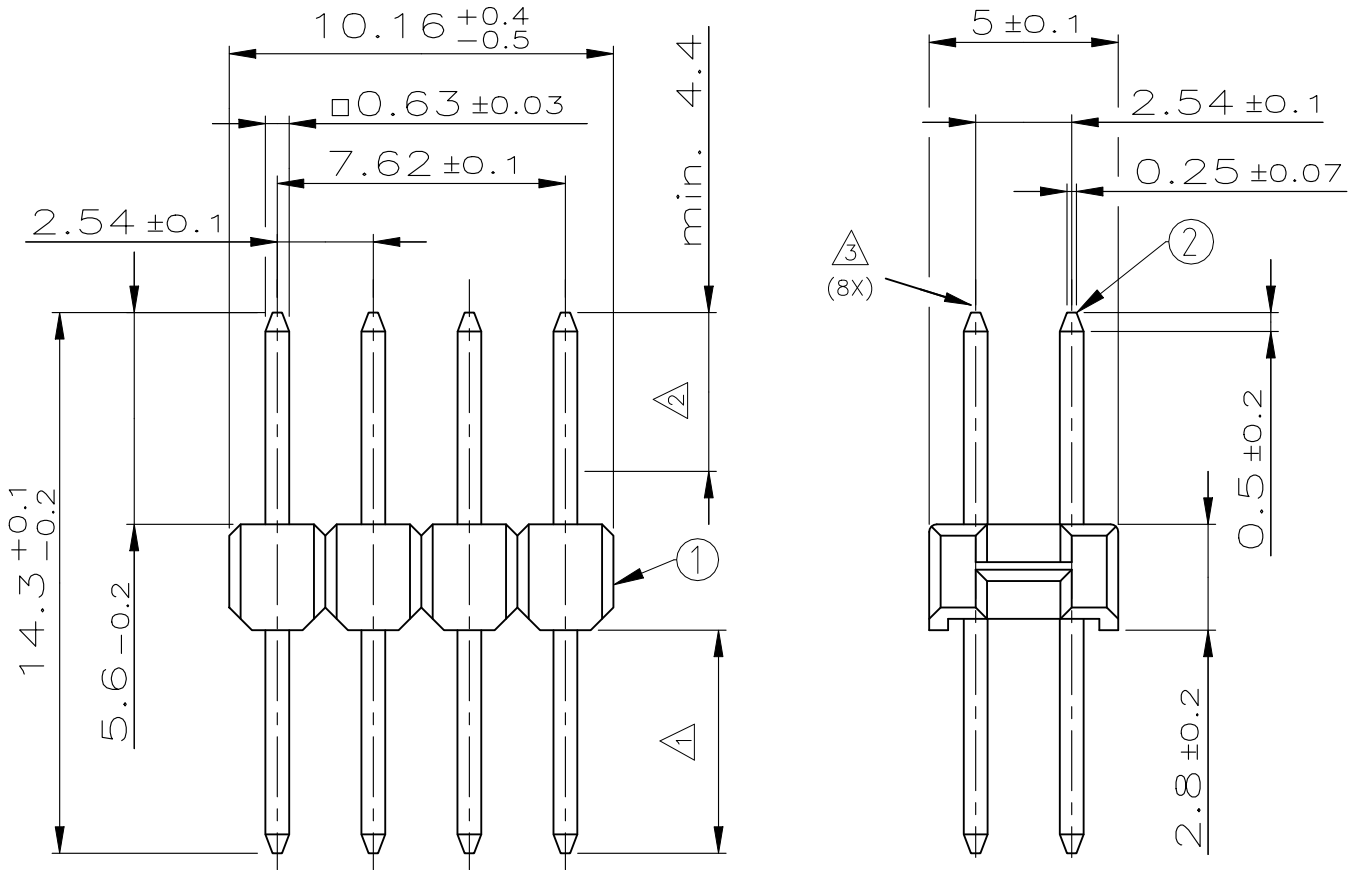

NOTES:

- ① MIN. 3.0–5.0µm Sn OVER 1.27µm Ni
- ② MATING SIDE: Min 0.76µm (PdNi + Au FLASH) IN ZONE "F" OVER Min 1.27µm Ni (Alternative plating – Min 0.76µm Au OVER Min 1.27µm Ni)
- ③ NO BURRS PERMITTED
- 4 PARTS WITHOUT BURRS AND SHAVINGS

0 – 4As shown

1241126-4	△ △	CuSn	CONTACT PIN	2
	BLACK	PBT	HOUSING	1
PART NO.	FINISH/COLOR	MATERIAL	DESCRIPTION	ITEM NO.

TE Connectivity. All Rights Reserved.



DIMENSIONS: MASSENHEITEN mm	DWN A. Zitz 24JAN1998	MATERIAL SEE TABLE	FINISH OBERFLÄCHE/FARBE SEE TABLE
	CHK U. Laudenschach 24JUN1998	TE Connectivity	
TOLERANCES UNLESS OTHERWISE SPECIFIED: ALLGEMEINTOLERANZEN A. ISO 2768 - MH - E B. ISO 15001 - 140	APVD -		
0 PLC ± - 1 PLC ± - 2 PLC ± - 3 PLC ± - 4 PLC ± - ANGLES / WINKEL ± -	PRODUCT SPEC PRODUKTSPEZ. 108-18012	SIZE A4	CAGE CODE 00779
	APPLICATION SPEC VERARBEITUNGSSPEZ. -	DRAWING NO ZEICHNUNGS-NR. 1241126	RESTRICTED TO NUR FUER -
	WEIGHT GEWICHT -	CUSTOMER DRAWING / KUNDENZEICHNUNG	
		SCALE MASSSTAB 5:1	SHEET BLATT 1 OF 1
			REV E1