

Verpackt im Gurt in Anlehnung an DIN IEC 60286-3
tape on reel packaging according to DIN IEC 60286-3
Verpackungseinheit: 560 Stück
packaging unit: 560 pcs

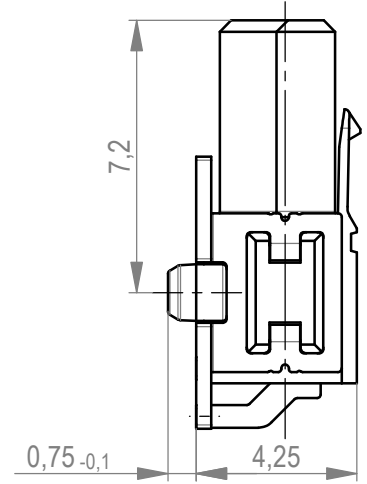

Abspulrichtung - reel off direction

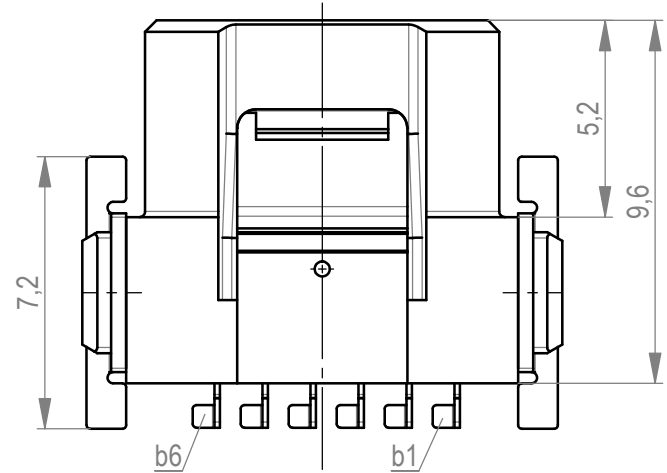
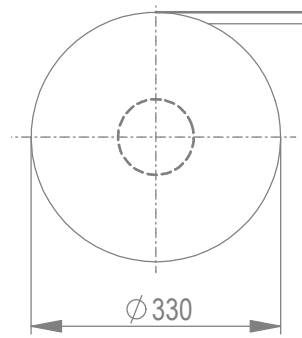
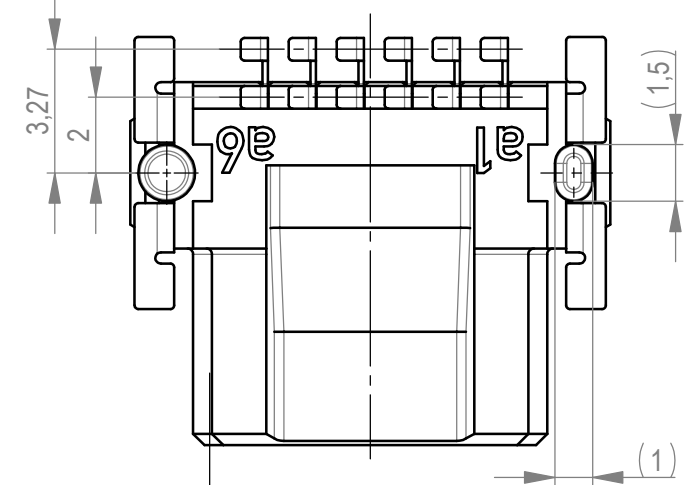
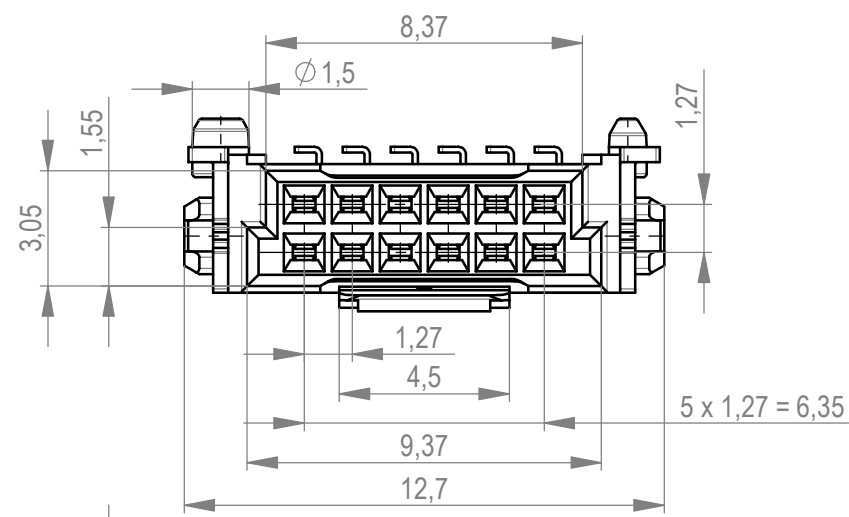
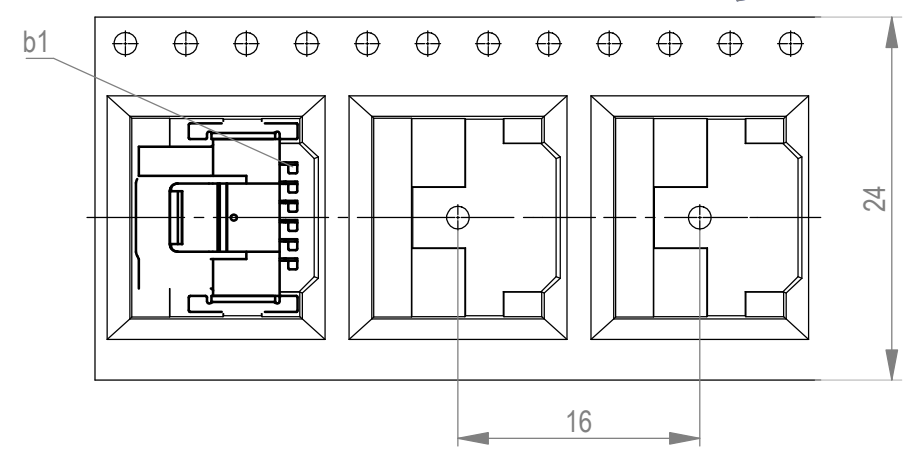

Anforderungsstufe 1
performance level 1

Kontaktbereich vergoldet
mating area gold plating

Anschlussbereich verzinkt 4-6 μm
terminal area 4-6 μm tin plating

Koplanarität der Anschlüsse $\leq 0,1$ mm
coplanarity area of termination $\leq 0,1$ mm

Weitergabe sowie Vervielfältigung dieses Dokuments, Verwertung und Mitteilung seines Inhalts sind verboten, soweit nicht ausdrücklich gestattet. Zuwiderhandlungen verpflichten zu Schadenersatz. Alle Rechte für den Fall der Patent-, Gebrauchsmuster- oder Geschmacksmusterertragung vorbehalten. The reproduction, distribution and utilization of this document as well as the communication of its contents to others without express authorization is prohibited. Offenders will be held liable for the payment of damages. All rights reserved in the event of the grant of a patent, utility model or design.

Die deutsche Version dieser Zeichnung dient nur zur Erleichterung der Handhabung. Bei Abweichungen von dem englischen Original gilt das englische Original. The german version of this drawing has been offered for convenience only and may deviate from the english original. In case of any deviation the English version shall prevail.

*mit Verriegelung, ohne Hilfsmittel lösbar,
*with locking mechanism, without tool unlockable,

Dimension no. Gehäuserfarbe schwarz housing colour black	Tolerances Dim. for Information ISO 8015	All Dimensions in mm	Scale 5:1 Material
Customer drawing: This Drawing is a controlled Document.	Subject to modification without prior notice. Drawing will not be updated.		ERNI-SMC Female Angled Q Type 7 SMT 12p* C-354939-E
	Class SMCQ		
d1 Index	12.05.2023 Date		c A3