

# ***Rockchip RK808 Datasheet***

**Revision 1.6  
Aug.2019**

**Revision History**

<b>Date</b>	<b>Revision</b>	<b>Description</b>
2019-8-27	1.6	Update the package information
2019-7-4	1.51	1.delete dev_off_rst(bit 3) of DEVCTRL_REG
2019-1-7	1.5	1. adding ordering information for RK808-E
2017-7-27	1.4	1. EC table discharge resistor/ vddio sepc updated. 2. Register map DEV_OFF and DEV _OFF_RST updated.
2016-8-9	1.3	Update
2016-8-8	1.1	Update
2014-12-30	1.0	1. adding ordering information for RK808-B/RK808-C 2.adding BOOT11 start up sequence of RK808-B/RK808-C

## Table of Content

Table of Content .....	3
Figure Index .....	5
Table Index 6	
Warranty Disclaimer .....	7
Chapter 1 Introduction .....	8
1.1 Overview .....	8
1.2 Feature .....	8
1.3 Block Diagram .....	9
1.4 Typical Application Diagrams .....	10
Chapter 2 Package information .....	12
2.1 Ordering information .....	12
2.2 Top Marking .....	12
2.3 Dimension .....	14
2.4 Pin Assignment .....	15
2.5 Pinout Number Order .....	15
Chapter 3 Electrical Characteristics .....	20
3.1 Absolute Maximum Ratings .....	20
3.2 Recommended Operating Conditions .....	20
3.3 DC Characteristics .....	20
Chapter 4 Function Description .....	30
4.1 State Machine Description .....	30
4.2 Device Power on Enable Conditions .....	30
4.3 Device Power on Disable Conditions .....	31
4.4 Device Sleep Enable Conditions .....	31
4.5 Power Sequence .....	31
4.6 Boot Timing Characteristic .....	33
4.7 Device Turn on With PLUG_IN .....	34
4.8 Device Turn off With Falling Input Voltage .....	35
4.9 Timing Characteristics (Vin rising/falling and Plug-in) .....	35
4.10 Device State Control Through PWRON Signal .....	36
4.11 Timing Characteristics (PWRON, DEV_OFF) .....	36
4.12 Device Sleep State Control .....	37
4.13 Timing Characteristics (SLEEP) .....	37
Chapter 5 Register Description .....	38
5.1 Register Summary .....	38

5.2 Register Description ..... 40

Chapter 6 Thermal Management .....68

6.1 Overview..... 68

6.2 Package Thermal Characteristics ..... 68

## Figure Index

Fig. 1-1 Functional Block Diagram .....	9
Fig. 1-2 RK808 One Battery Cell Application .....	10
Fig. 1-3 RK808 Two Battery Cells Application .....	11
Fig. 2-1 RK808-X QFN68 7mm X 7mm Package Top View .....	14
Fig. 2-2 Pin Assignment .....	15
Fig. 4-1 State Machine .....	30
Fig. 4-2 Power On Enable Control .....	31
Fig. 4-3 SLEEP Enable Control .....	31
Fig. 4-4 Power On/Off Timing, BOOT1=0, BOOT0=0 .....	32
Fig. 4-5 Power On/Off Timing, BOOT1=0, BOOT0=1 .....	33
Fig. 4-6 Power On/Off Timing, BOOT1=1, BOOT0=0 .....	33
Fig. 4-10 Power ON Timing with VDC Plug in (PLUP_IN_INT Trigger a Power on Enable) .....	34
Fig. 4-11 Power Control Timing with VIN Falling .....	35
Fig. 4-12 PWRON Turn-On/DEV_OFF Turn Off .....	36
Fig. 4-13 PWRON Long Press Turn Off .....	36
Fig. 4-14 SLEEP/ACTIVE Transition Timing .....	37

## **Table Index**

Table 4-1 Power Start Up Sequence .....	32
Table 4-2 Boot Timing Characteristics .....	33
Table 4-4 Vin and PLUG_IN Timing Characteristics .....	35
Table 4-3 PWRON/DEV_OFF Timing Characteristics .....	37
Table 4-4 SLEEP Timing Characteristics .....	37
Table 6-1 Thermal Resistance Characteristics .....	68

## Warranty Disclaimer

Rockchip Electronics Co., Ltd makes no warranty, representation or guarantee (expressed, implied, statutory, or otherwise) by or with respect to anything in this document, and shall not be liable for any implied warranties of non-infringement, merchantability or fitness for a particular purpose or for any indirect, special or consequential damages.

Information furnished is believed to be accurate and reliable. However, Rockchip Electronics Co., Ltd assumes no responsibility for the consequences of use of such information or for any infringement of patents or other rights of third parties that may result from its use.

Rockchip Electronics Co., Ltd's products are not designed, intended, or authorized for using as components in systems intended for surgical implant into the body, or other applications intended to support or sustain life, or for any other application in which the failure of the Rockchip Electronics Co., Ltd's product could create a situation where personal injury or death may occur, should buyer purchase or use Rockchip Electronics Co., Ltd's products for any such unintended or unauthorized application, buyers shall indemnify and hold Rockchip Electronics Co., Ltd and its officers, employees, subsidiaries, affiliates, and distributors harmless against all claims, costs, damages, expenses, and reasonable attorney fees arising out of, either directly or indirectly, any claim of personal injury or death that may be associated with such unintended or unauthorized use, even if such claim alleges that Rockchip Electronics Co., Ltd was negligent regarding the design or manufacture of the part.

## Copyright and Patent Right

Information in this document is provided solely to enable system and software implementers to use Rockchip Electronics Co., Ltd 's products. There are no expressed or implied copyright licenses granted hereunder to design or fabricate any integrated circuits or integrated circuits based on the information in this document.

**Rockchip Electronics Co., Ltd does not convey any license under its patent rights nor the rights of others.**

**All copyright and patent rights referenced in this document belong to their respective owners and shall be subject to corresponding copyright and patent licensing requirements.**

## Trademarks

Rockchip and Rockchip™ logo and the name of Rockchip Electronics Co., Ltd's products are trademarks of Rockchip Electronics Co., Ltd. and are exclusively owned by Rockchip Electronics Co., Ltd. References to other companies and their products use trademarks owned by the respective companies and are for reference purpose only.

## Confidentiality

The information contained herein (including any attachments) is confidential. The recipient hereby acknowledges the confidentiality of this document, and except for the specific purpose, this document shall not be disclosed to any third party.

## Reverse engineering or disassembly is prohibited.

**ROCKCHIP ELECTRONICS CO.,LTD. RESERVES THE RIGHT TO MAKE CHANGES IN ITS PRODUCTS OR PRODUCT SPECIFICATIONS WITH THE INTENT TO IMPROVE FUNCTION OR DESIGN AT ANY TIME AND WITHOUT NOTICE AND IS NOT REQUIRED TO UNDATE THIS DOCUMENTATION TO REFLECT SUCH CHANGES.**

## Copyright © 2019 Rockchip Electronics Co., Ltd.

All rights reserved. No part of this publication may be reproduced, stored in a retrieval system, or transmitted in any form or by any means, electric or mechanical, by photocopying, recording, or otherwise, without the prior written consent of Rockchip Electronics Co., Ltd.

## Chapter 1 Introduction

### 1.1 Overview

The RK808 is a complete power supply solution for Portable systems. The highly integrated device includes four buck DC-DC converters, eight high performance Idos, two low Rds switches, I<sup>2</sup>C interface, programmable power sequencing and an RTC.

The RK808 improves performance, reduces component count and size, and therefore provides lower cost solution compared to conventional portable designs. The ultra fast 2MHz current mode DC/DC architecture optimizes the transient performance and is compatible with tiny low cost ceramic inductors and capacitors. All DC/DC channels include integrated MOSFETS. Internal soft-start and compensation circuits minimize external components count. Most outputs can be programmed through the I<sup>2</sup>C interface

### 1.2 Feature

- Input voltage range: 2.7V to 5.5V
- 2MHz Switching Frequency for bucks
- Current mode architecture for best transient performance
- Internal compensation and soft start
- I<sup>2</sup>C Programmable output levels and power sequencing
- High efficiency architecture
- Integrated Vout Discharge Circuit for BUCK and LDO
- Power:
  - CH1: Synchronous Buck regulator, 5A max
  - CH2: Synchronous Buck regulator, 5A max
  - CH3: Synchronous Buck regulator, 3A max
  - CH4: Synchronous Buck regulator, 2.5A max
  - CH6,CH7,CH9,CH11: Linear regulators, 150mA max
  - CH8: Low noise and high PSRR linear regulator,100mA max
  - CH10,CH12,CH13: Linear regulators, 300mA max
  - CH14: Low Rds switch, 0.2ohm@Vgs=3v
  - CH15: Low Rds switch, 0.2ohm@Vgs=3v
- Auxiliary: Flexible Power Sequence control
- Package: 7mmx7mm QFN68



### 1.3 Block Diagram

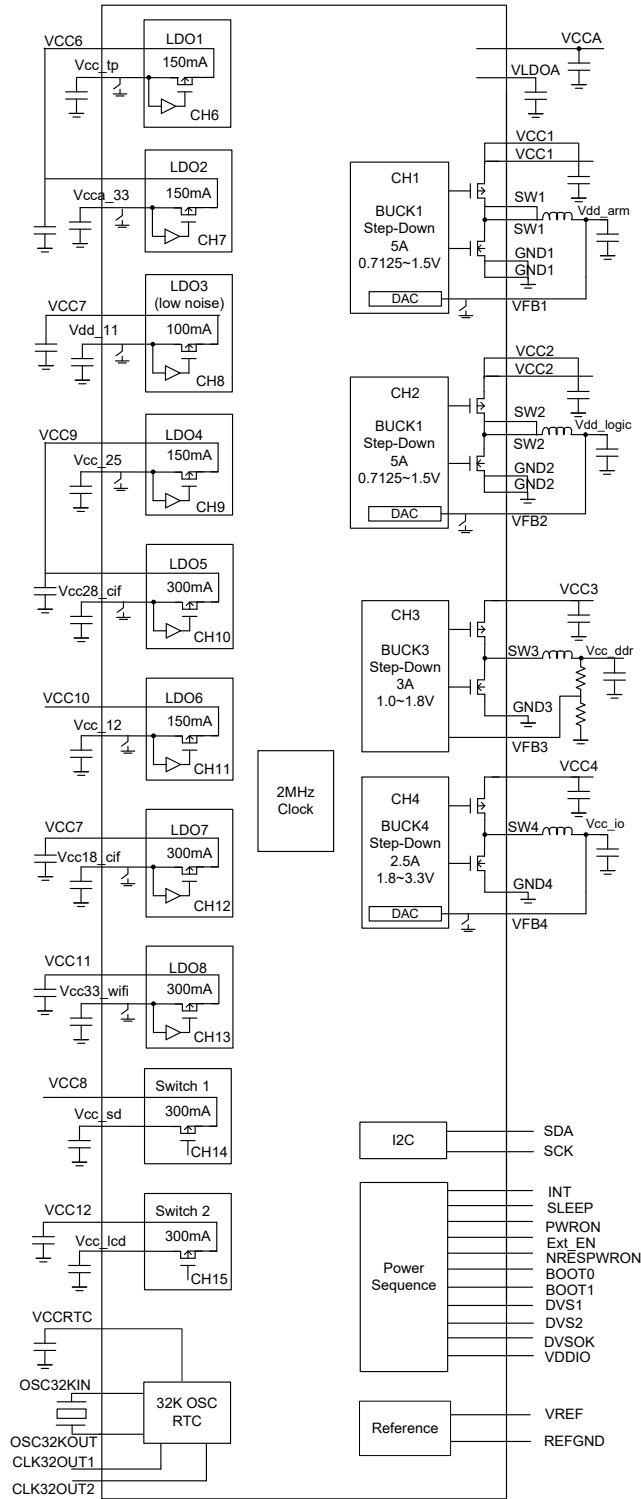

Fig. 1-1 Functional Block Diagram

### 1.4 Typical Application Diagrams

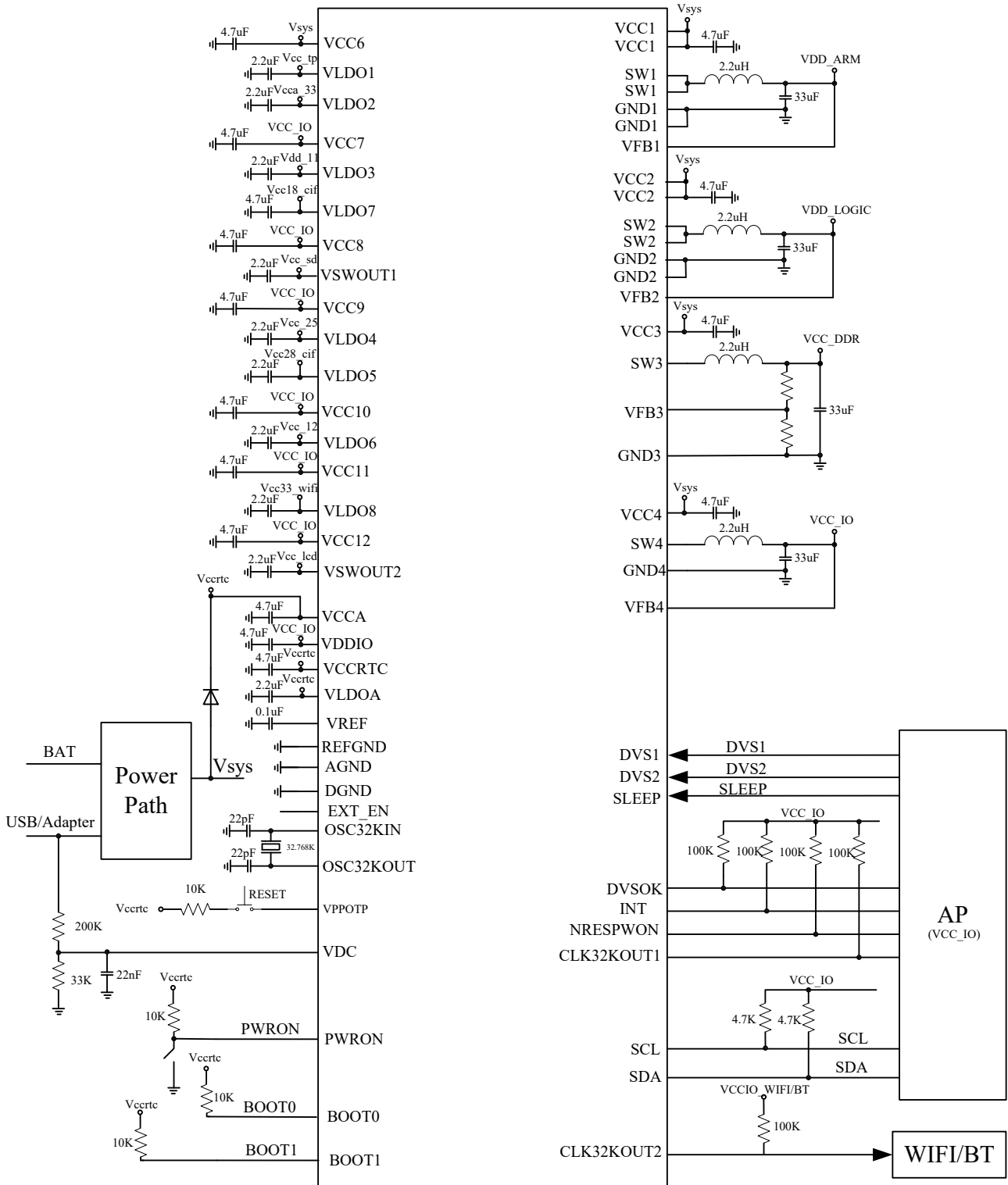

Fig. 1-2 RK808 One Battery Cell Application



## Chapter 2 Package information

### 2.1 Ordering information

Orderable Device	RoHS status	Package	Old Packaging before date code 1949(2019/12/2)	New Packaging after date code 1949(2019/12/2)
RK808-B	RoHS pass	QFN68(7X7)	2600pcs per tray in one box 6 boxes per carton	2100pcs per reel in one box 5 boxes per carton
RK808-C	RoHS pass	QFN68(7X7)	2600pcs per tray in one box 6 boxes per carton	2100pcs per reel in one box 5 boxes per carton
RK808-D	RoHS pass	QFN68(7X7)	2600pcs per tray in one box 6 boxes per carton	2100pcs per reel in one box 5 boxes per carton
RK808-E	RoHS pass	QFN68(7X7)	2600pcs per tray in one box 6 boxes per carton	2100pcs per reel in one box 5 boxes per carton

### 2.2 Top Marking

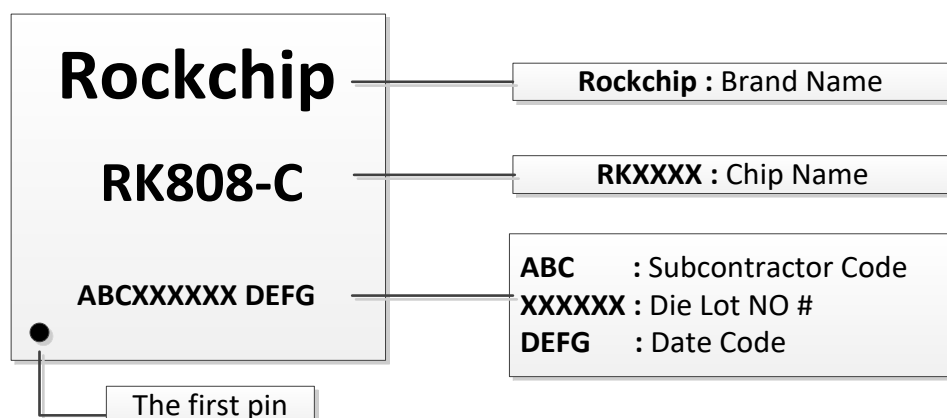
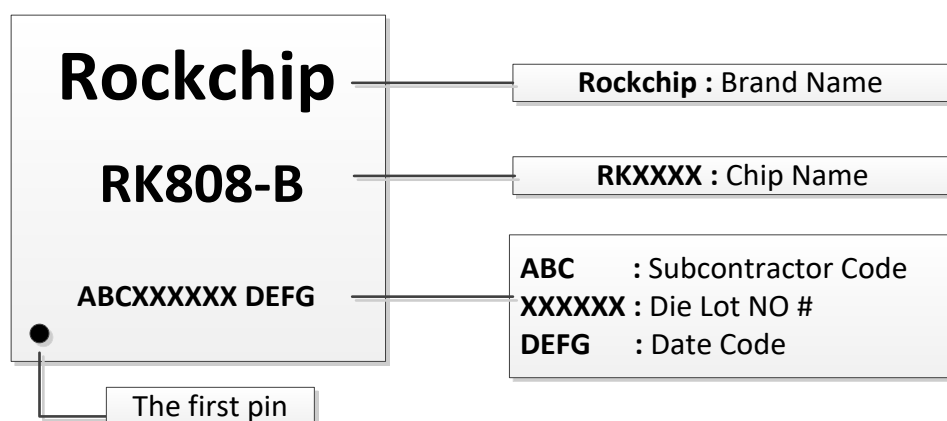

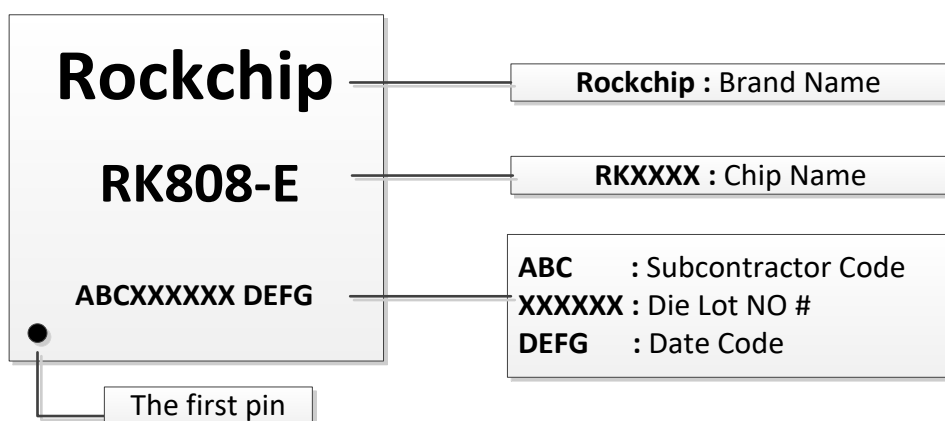
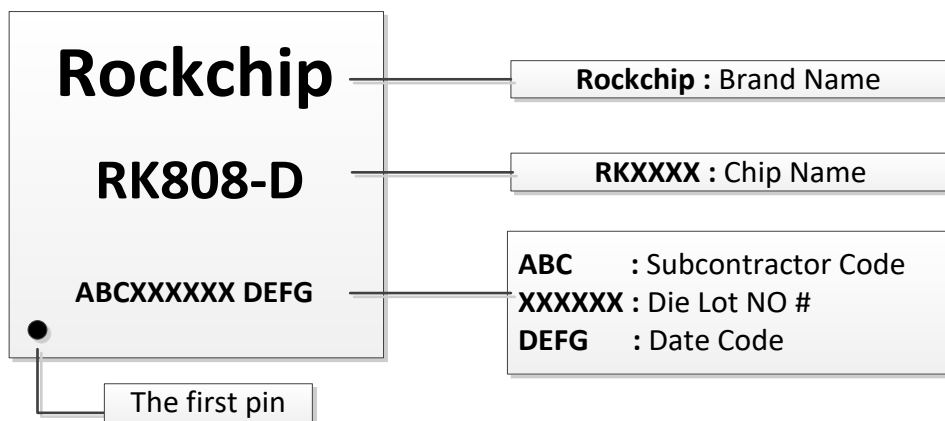

### 2.3 Dimension

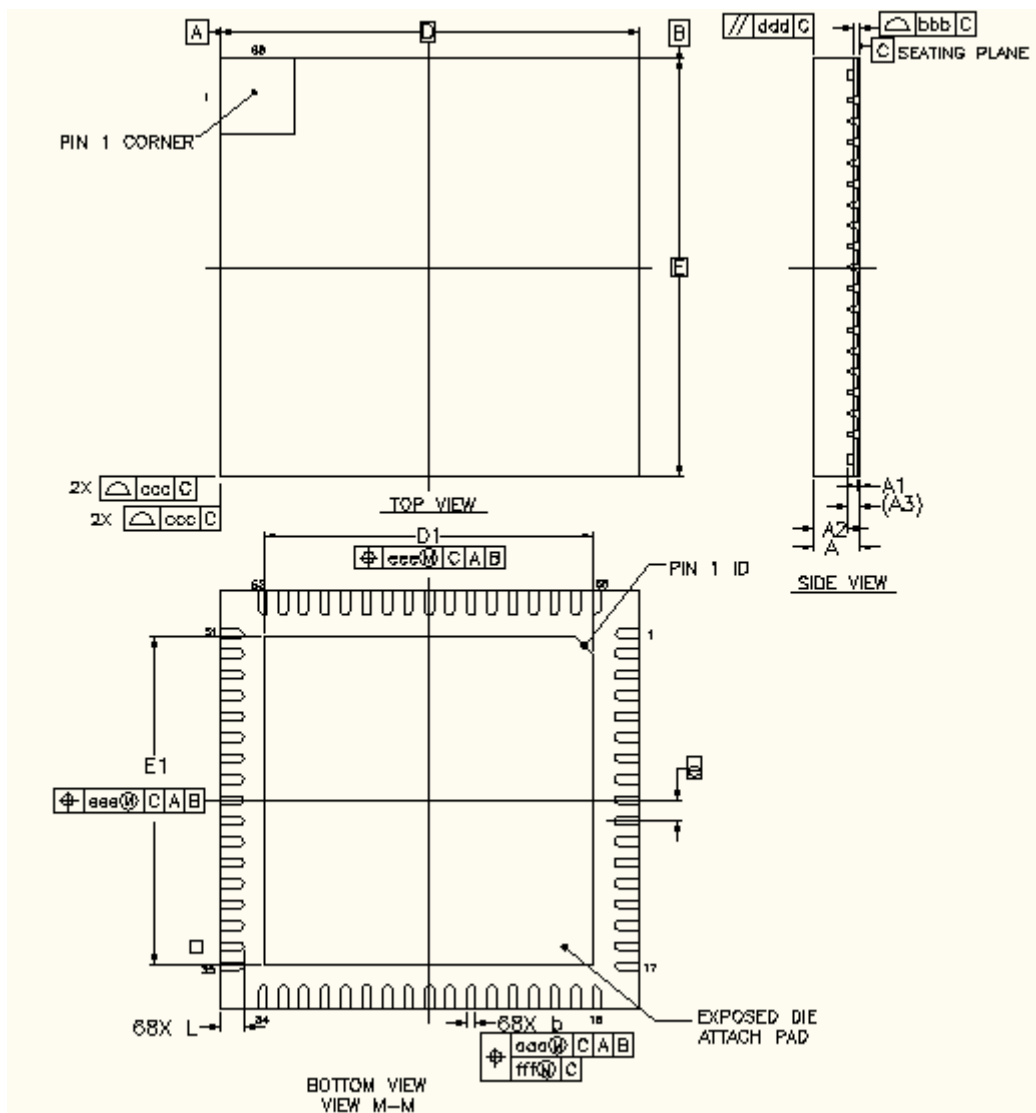

Fig. 2-1 RK808-X QFN68 7mm X 7mm Package Top View

DESCRIPTION	SYMBOL	MILLIMETER		
		MIN	NOM	MAX
TOTAL THICKNESS	A	0.70	0.75	0.80
STAND OFF	A1	0	0.035	0.05
MOLD THICKNESS	A2	-	0.55	0.57
MATERIAL THICKNESS	A3	-	0.203 <sub>REF</sub>	-
PACKAGE SIZE	D	-	7 <sub>BSC</sub>	-
	E	-	7 <sub>BSC</sub>	-
EP SIZE	D1	5.39	5.49	5.59
	E1	5.39	5.49	5.59
LEAD LENGTH	L	0.30	0.4	0.50
LEAD PITCH	e	0.35 <sub>BSC</sub>		
LEAD WIDTH	b	0.1	0.15	0.2

DESCRIPTION	SYMBOL	MILLIMETER		
		MIN	NOM	MAX
LEAD OSITION OFFSET	aaa		0.07	
LEAD COPLANARITY	bbb		0.08	
PACKAGE EDGE PROFILE	ccc		0.10	
MOLD FLATNESS	ddd		0.10	
EP POSITION OFFSET	eee		0.10	
	fff		0.05	

**Note:**

- Coplanarity applies to leads, corner leads and die attach pad.
- Dimension b applies to metalized terminal and is measured between 0.15mm and 0.30mm from the terminal tip. If the terminal has the optional radius on the other end of the terminal, the dimension b should not be measure in that radius area.
- 0.15mm of dimension b is recommended in PCB layout.

## 2.4 Pin Assignment

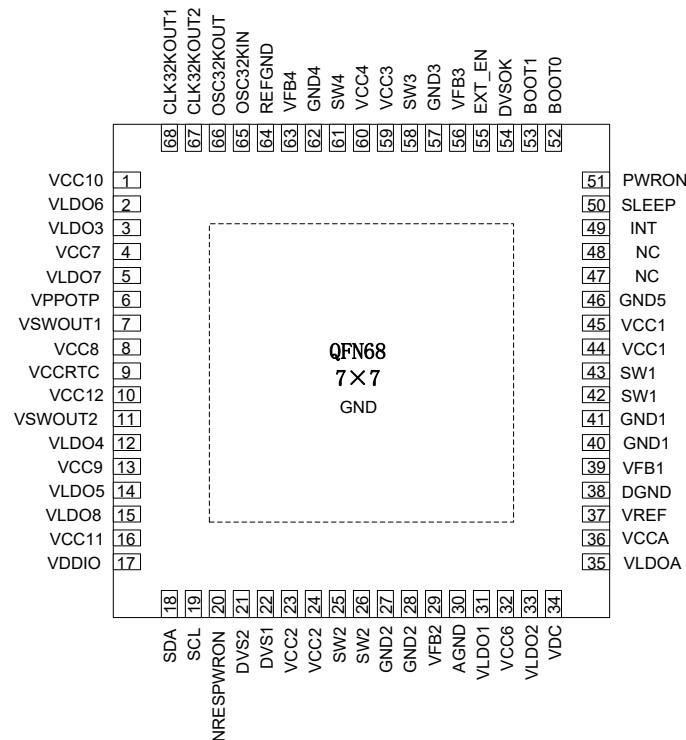

Fig. 2-2 Pin Assignment

## 2.5 Pinout Number Order

NO	NAME	SUPPLIES	FUNCTIONAL	TYPE	I/O	DESCRIPTION
			BLOCK			
9	VCCRTC	VCCRTC	RTC	Power	I	RTC power supply
		/AGND				
65	OSC32KIN	VCCRTC /DGND		Analog	I	32KHz crystal oscillator input
66	OSC32KOUT	VCCRTC /DGND	Analog	O	32KHz crystal oscillator output	

NO	NAME	SUPPLIES	FUNCTIONAL	TYPE	I/O	DESCRIPTION	
			BLOCK				
68	CLK32KOUT1	VCCRTC /DGND		Digital	O	32KHz clock output 1,OD output (always on)	
67	CLK32KOUT2	VCCRTC /DGND		Digital	O	32KHz clock output 2,OD output	
37	VREF	VCCA /REFGND	REFERENCE	Analog	O	bandgap voltage	
64	VREFGND	REFGND		Analog	Gnd	reference ground	
36	VCCA	VCCA /GNDA	Analog Power	Power	I	power supply for	
6	VPPOTP	VPPOTP /GNDA	Analog Power	Power	I	OTP power supply	
45	VCC1	VCC1 /GND1	BUCK1	Power	I	buck1 dc-dc power supply	
44	VCC1	VCC1 /GND1		Power	I	buck1 dc-dc power supply	
43	SW1	VCC1 /GND1		Power	I/O	buck1 dc-dc switch output	
42	SW1	VCC1 /GND1					
41	GND1	VCC1 /GND1		Power	Gnd	buck1 dc-dc switch ground	
40	GND1	VCC1 /GND1					
39	VFB1	VCC1 /REFGND		Analog	I	buck1 dc-dc switch feedback voltage	
23	VCC2	VCC2 /GND2		BUCK2	Power	I	buck2 dc-dc power supply
24	VCC2	VCC2 /GND2			Power	I	buck2 dc-dc power supply
25	SW2	VCC2 /GND2			Power	I/O	buck2 dc-dc switch output
26	SW2	VCC2 /GND2	Power		I/O	buck2 dc-dc switch output	
27	GND2	VCC2 /GND2	Power		Gnd	buck2 dc-dc switch ground	
28	GND2	VCC2 /GND2	Power		Gnd	buck2 dc-dc switch ground	
29	VFB2	VCC2 /REFGND	Analog		I	buck2 dc-dc switch feedback voltage	
59	VCC3	VCC3 /GND3	BUCK3		Power	I	buck3 dc-dc power supply
58	SW3	VCC3		Power	I/O	buck3 dc-dc switch	



NO	NAME	SUPPLIES	FUNCTIONAL	TYPE	I/O	DESCRIPTION	
			BLOCK				
		/GND3				output	
57	GND3	VCC3		Power	Gnd	buck3 dc-dc switch ground	
		/GND3					
56	VFB3	VCC3		Analog	I	buck3 dc-dc switch feedback voltage	
		/REFGND					
60	VCC4	VCC4	BUCK4	Power	I	buck4 dc-dc power supply	
		/GND4					
61	SW4	VCC4			Power	I/O	buck4 dc-dc switch output
		/GND4					
62	GND4	VCC4			Power	Gnd	buck4 dc-dc switch ground
		/GND4					
63	VFB4	VCC4			Analog	I	buck4 dc-dc switch feedback voltage
		/REFGND					
47	NC						
46	GND5	VCCA		Power	Gnd	ground	
		/GND5					
48	NC						
32	VCC6	VCC6	LDO 1~8, SWITCH1,2	Power	I	LDO1,LDO2 power supply	
		/AGND					
4	VCC7	VCC7		Power	I	LDO3,LDO7 power supply	
		/AGND					
8	VCC8	VCC8		Power	I	SWITCH1 power supply	
		/AGND					
13	VCC9	VCC9		Power	I	LDO4,LDO5 power supply	
		/AGND					
1	VCC10	VCC11		Power	I	LDO6 power supply	
		/AGND					
16	VCC11	VCC11		Power	I	LDO8 power supply	
		/AGND					
10	VCC12	VCC12		Power	I	SWITCH2 power supply	
		/AGND					
31	VLDO1	VCC7		Power	O	LDO1 regulator output	
		/AGND					
33	VLDO2	VCC7		Power	O	LDO2 regulator output	
		/AGND					
3	VLDO3	VCC8		Power	O	LDO3 regulator output	
		/AGND					
12	VLDO4	VCC9		Power	O	LDO4 regulator output	
		/AGND					
14	VLDO5	VCC10		Power	O	LDO5 regulator output	
		/AGND					
2	VLDO6	VCC9		Power	O	LDO6 regulator output	
		/AGND					

NO	NAME	SUPPLIES	FUNCTIONAL	TYPE	I/O	DESCRIPTION	
			BLOCK				
5	VLDO7	VCC1		Power	O	LDO7 regulator output	
		1/AGND					
15	VLDO8	VCC11		Power	O	LDO8 regulator output	
		/AGND					
7	VSWOUT1	VCC8		Power	O	Switch 1 output	
		/AGND					
11	VSWOUT2	VCC12		Power	O	Switch 2 output	
		/AGND					
30	AGND	POWER PAD	Analog ground	Power	Gnd	Analog ground	
35	VLDOA	POWER PAD	LDOA	Power	I	supply for internal analog circuit	
38	DGND	POWER PAD	Digital ground	Power	Gnd	Digital ground	
17	VDDIO	VDDIO	IO	Power	I	Digital I/O power supply	
		/DGND					
50	SLEEP	VDDIO		Digital	I	Active-Sleep state transition control signal	
		/DGND					
20	NRESPWRON	VDDIO		Digital	O	Power off reset for AP/ External reset digital core(excludes RTC)	
		/DGND					
49	INT	VDDIO		IO	Digital	O	Interrupt flag (polarity is I2C programmable, default active high)
		/DGND					
51	PWRON	VCCRTC			Digital	I	External switch-on control signal(ON button)
		/DGND					
18	SDA	VDDIO	Digital		I/O	I2C data signal	
		/DGND					
19	SCL	VDDIO	Digital		I/O	I2C clock signal	
		/DGND					
52	BOOT0	VCCRTC /DGND	IO		Digital	I	Power-up sequence selection
53	BOOT1	VCCRTC /DGND			Digital	I	Power-up sequence selection
55	EXT_EN	VCCRTC /DGND		Digital	O	Output enable for external BUCK in two-battery-cells application	
22	DVS1	VDDIO		Digital	I	BUCK1 DVS voltage	

NO	NAME	SUPPLIES	FUNCTIONAL	TYPE	I/O	DESCRIPTION	
			BLOCK				
		/DGND				/normal voltage transition control signal(polarity is I2C programmable, default active high)	
21	DVS2	VDDIO		Digital	I	BUCK2 DVS voltage	/normal voltage transition control signal(polarity is I2C programmable, default active high)
		/DGND					
54	DVSOK	VDDIO		Digital	O	BUCK1 and BUCK2 power good flag after dynamic voltage setting	
		/DGND					
34	VDC	VDC	Digital	I	Adapter voltage detect input		
		/AGND					

## Chapter 3 Electrical Characteristics

### 3.1 Absolute Maximum Ratings

Parameter	Min	Max	Units
Voltage range on pins VCCx, VDDIO, VCCRTC, VFBx, VLDOx, VSWOUTx, VREF	-0.3	7	V
Voltage range on pin CLK32KOUT1, CLK32KOUT2, VDC, SLEEP	-0.3	7	V
Voltage range on pins OSC32KIN, OSC32KOUT, BOOT0, BOOT1, EXT_EN, PWRON	-0.3	VCCRTC <sub>MAX</sub> +0.3	
Voltage range on pins NRESPWRON, INT, SDA, SCL, DVS1, DVS2, DVSOK	-0.3	VDDIO+0.3	V
Storage temperature range, T <sub>S</sub>	-40	150	°C
Operating temperature range, T <sub>J</sub>	-40	125	°C
Maximum Soldering Temperature, T <sub>SOLDER</sub>		260	°C

Note 1. Exposure to the conditions exceeded absolute maximum ratings may cause the permanent damages and affect the reliability and safety of both device and systems using the device. The functional operations cannot be guaranteed beyond specified values in the recommended conditions.

### 3.2 Recommended Operating Conditions

Parameter	Min	TYP	Max	Units
Voltage range on pins VCCx	3		5.5	V
Voltage range on pins VDDIO	1.8		5.5	V
Voltage range on pin VCCRTC	2.5		5.5	V
Voltage range on other pins			5.5	V
Power Dissipation			2.5	W

### 3.3 DC Characteristics

T<sub>J</sub>=25°C; V<sub>BAT</sub>=VCCx=3.8V, VDDIO=3V unless otherwise specified.

Parameter	Symbol	Min.	Typ.	Max.	Unit
<b>General</b>					
Input supply voltage range (VBAT)	V <sub>INPUT</sub>	2.7		5.5	V
Battery low alarm voltage (2.8V~3.5V programmable, step=100mV)	V <sub>BLO</sub>	3.25	3.3	3.35	V
Battery under voltage threshold (vin falling)	V <sub>BUVL</sub>		2.5		V
Battery under voltage threshold (vin rising)	V <sub>BUVH</sub>	2.6	2.7	2.8	V
Battery OK voltage threshold (3.0V/3.4V/3.5V/3.6V OTP programmable)	V <sub>BOK</sub>		3.0		V
Power on Reset Threshold (Rising)	V <sub>PORH</sub>			2.2	V

Parameter	Symbol	Min.	Typ.	Max.	Unit
Power on Reset Threshold (Falling)	V <sub>PORL</sub>	1.2			V
Over Voltage Lock Out Threshold (Vin Rising)	V <sub>TH(OVLO)</sub>	5.7	6.0	6.3	V
Over Voltage Lock Out Hysteresis	V <sub>HYS (OVLO)</sub>		0.2		V
VDC pin threshold(rising edge)	V <sub>DCH</sub>		0.6		V
VDC pin threshold(falling edge)	V <sub>DCL</sub>		0.54		V
Stand-by current, V <sub>DD</sub> =3.6V, device OFF state 32KHz clock running	I <sub>Q(STNBY)</sub>		60		uA
Hot-die temperature rising threshold (85°C~115°C programmable, step=10°C)	T <sub>HD</sub>	85		115	°C
Thermal shut down (140°C~170°C programmable, step=30°C)	T <sub>TSD</sub>	140		170	°C
<b>Oscillator circuit</b>					
Switching Frequency CH1,2,3,4( T <sub>j</sub> =25°C )	f <sub>sw</sub>	1.8	2	2.2	MHz
<b>Logic inputs</b>					
Input LOW-Level Voltage (V <sub>DDIO</sub> )	V <sub>IL</sub>			0.3xV <sub>DDIO</sub>	V
Input HIGH-Level Voltage (V <sub>DDIO</sub> )	V <sub>IH</sub>	0.7xV <sub>DDIO</sub>			V
<b>Logic outputs</b>					
LOW-Level Output Voltage, 3.0 mA sink current	V <sub>OL</sub>			0.4	V
HIGH-Level Output Voltage, 3.0 mA source current	V <sub>OH</sub>	V <sub>DDIO</sub> -0.4			V
NRESPWON pin LOW-Level Output Voltage, 3.0mA sink current	V <sub>OL(NRES)</sub>			0.4	V
CLK32KOUT1 pin LOW-Level Output Voltage, 3.0mA sink current	V <sub>OL(CLKO1)</sub>			0.4	V
CLK32KOUT2 pin LOW-Level Output Voltage, 3.0mA sink current	V <sub>OL(CLKO2)</sub>			0.4	
CLK32KOUT2 pin HIGH-Level Output Voltage, 3.0mA source current	V <sub>OH(CLKO2)</sub>	V <sub>CCRTC</sub> -0.4			V
<b>CH1 Buck1 Regulator</b>					
Input supply voltage range	V <sub>INPUT1</sub>	2.7		5.5	V
Voltage Adjustable Range, 6bit	V <sub>FB1</sub>	0.7125		1.500	V
DC output voltage programmable step(DVS)			12.5		mV
Output voltage transition rate BUCK1_RATE=00 BUCK1_RATE=01 BUCK1_RATE=10 BUCK1_RATE=11			2 3.6 5 6.5		mV/us
DVS OK threshold (Vout rising)	V <sub>DVSOKR1</sub>		93		%
DVS OK threshold (Vout falling)	V <sub>DVSOKF1</sub>		107		%
Power Good threshold (Vout rising)	V <sub>PG1</sub>		93		%
Output under voltage lockout(Vout falling)	V <sub>UV1</sub>		85		%
Output over voltage lockout (Vout rising)	V <sub>OV1</sub>		117		%

Parameter	Symbol	Min.	Typ.	Max.	Unit
Preset Voltage, Default( Tj=25°C )	V <sub>FB1(Default)</sub>	1.078	1.100	1.122	V
Preset Voltage, Default(-10°C ≤ Tj ≤ +85°C)	V <sub>FB1(Default)</sub>	1.067	1.100	1.133	V
Load Regulation, I <sub>OUT1</sub> = 100mA to 5A			1		%/A
Line Regulation, V <sub>CC1</sub> = 3 to 5V, I <sub>OUT1</sub> = 1A			0.1		%/V
Rated output current(If I <sub>CL1</sub> =6A)	I <sub>MAX1</sub>		5		A
Switch Current Limit (4.5A~6A programmable, step=0.5A)	I <sub>CL1</sub>		6		A
Operating Quiescent Current, No load, V <sub>DD</sub> =3.8V	I <sub>Q1</sub>		70		uA
Minimun Switch Current Limit (50mA~400mA programmable, step=50mA)	I <sub>CLMIN1</sub>		100		mA
Soft-start Time	t <sub>SS1</sub>		400		us
C <sub>OUT</sub> Discharge Switch ON Resistance	R <sub>DIS1</sub>		400		ohm
Conversion Efficiency (Vin=3.8V,Vout=1.1V)					
I <sub>out</sub> =5A			68		
I <sub>out</sub> =4A			73		
I <sub>out</sub> =3A			78		
I <sub>out</sub> =2A			84		
I <sub>out</sub> =1 A			89		
I <sub>out</sub> =500mA			90		
I <sub>out</sub> =100 mA			81		
I <sub>out</sub> =10 mA			79		
					%
<b>CH2 Buck2 Regulator</b>					
Input supply voltage range	V <sub>INPUT2</sub>	2.7		5.5	V <sub>INPUT2</sub>
Voltage Adjustable Range, 6bit	V <sub>FB2</sub>	0.7125		1.500	V <sub>FB2</sub>
DC output voltage programmable step(DVS)			12.5		
Output voltage transition rate					
BUCK2_RATE=00			2		
BUCK2_RATE=01			3.6		
BUCK2_RATE=10			5		
BUCK2_RATE=11			6.5		
DVS OK threshold (Vout rising)	V <sub>DVSOKR2</sub>		93		%
DVS OK threshold (Vout falling)	V <sub>DVSOKF2</sub>		107		%
Power Good threshold (Vout rising)	V <sub>PG2</sub>		93		%
Output under voltage lockout (Vout falling)	V <sub>UV2</sub>		85		%
Output over voltage lockout (Vout rising)	V <sub>OV2</sub>		117		%
Preset Voltage, Default( Tj=25°C )	V <sub>FB2(Default)</sub>	1.078	1.100		V
Preset Voltage, Default(-10°C ≤ Tj ≤ +85°C)	V <sub>FB2(Default)</sub>	1.067	1.100		V
Load Regulation, I <sub>OUT2</sub> = 100 mA to 5A			1		%/A
Line Regulation, V <sub>CC2</sub> = 3 to 5V, I <sub>OUT2</sub> = 1A			0.1		%/V
Rated output current(If I <sub>CL2</sub> =6A)	I <sub>MAX2</sub>		5		A

Parameter	Symbol	Min.	Typ.	Max.	Unit
Switch Current Limit (4.5A~6A programmable, step=0.5A)	I <sub>CL2</sub>		6		A
Operating Quiescent Current, No load, V <sub>DD</sub> =3.8V	I <sub>Q2</sub>		70		uA
Minimum Switch Current Limit (50mA~400mA programmable, step=50mA)	I <sub>CLMIN2</sub>		100		mA
Soft-start Time	t <sub>SS2</sub>		400		us
C <sub>OUT</sub> Discharge Switch ON Resistance	R <sub>DIS2</sub>		400		ohm
Conversion Efficiency (Vin=3.8V,Vout=1.1V)					
I <sub>out</sub> =5A			68		%
I <sub>out</sub> =4A			73		
I <sub>out</sub> =3A			78		
I <sub>out</sub> =2A			84		
I <sub>out</sub> =1 A			89		
I <sub>out</sub> =500mA			90		
I <sub>out</sub> =100 mA			81		
I <sub>out</sub> =10 mA			79		
<b>CH3 Buck3 Regulator</b>					
Input supply voltage range	V <sub>INPUT3</sub>	2.7		5.5	V
Feedback Voltage, Default( T <sub>j</sub> =25°C )	V <sub>FB3(Default)</sub>	0.98	1.00		V
Feedback Voltage, Default(-10°C ≦ T <sub>j</sub> ≦ +85°C)	V <sub>FB3(Default)</sub>	0.97	1.00		V
Power Good threshold (V <sub>out</sub> rising)	V <sub>PG3</sub>		93		%
Output under voltage lockout (V <sub>out</sub> falling)	V <sub>UV3</sub>		85		%
Output over voltage lockout (V <sub>out</sub> rising)	V <sub>OV3</sub>		117		%
Load Regulation, I <sub>OUT3</sub> = 100mA to 3A			1		%/A
Line Regulation, V <sub>CC3</sub> = 3 to 5V, I <sub>OUT3</sub> = 0.5A			0.1		%/V
Rated output current(If I <sub>CL3</sub> =3.5A)	I <sub>MAX3</sub>		3		A
Switch Current Limit (2A~3.5A programmable, step=0.5A)	I <sub>CL3</sub>		3.5		A
Operating Quiescent Current, No load, V <sub>DD</sub> =3.8V	I <sub>Q3</sub>		70		uA
Minimum Switch Current Limit (50mA~400mA programmable, step=50mA)	I <sub>CLMIN3</sub>		100		mA
Soft-start Time	t <sub>SS3</sub>		400		us
C <sub>OUT</sub> Discharge Switch ON Resistance	R <sub>DIS3</sub>		250		ohm
Conversion Efficiency (Vin=3.8V,Vout=1.4V)					
I <sub>out</sub> =3A			71		%
I <sub>out</sub> =2A			79		
I <sub>out</sub> =1.5A			83		

Parameter	Symbol	Min.	Typ.	Max.	Unit
lout=1 A			87		
lout=500mA			90		
lout=100 mA			83		
lout=10 mA			76		
<b>CH4 Buck4 Regulator</b>					
Input supply voltage range	V <sub>INPUT4</sub>	2.7		5.5	V
Voltage Adjustable Range, 4bit	V <sub>FB4</sub>	1.8		3.3	V
DC output voltage programmable step(gain select)			100		mV
Feedback Voltage, Default( T <sub>j</sub> =25°C )	V <sub>FB4(Default)</sub>	2.94	3.00	3.06	V
Feedback Voltage, Default(-10°C ≦ T <sub>j</sub> ≦ +85°C)	V <sub>FB4(Default)</sub>	-2.91	3.00	3.09	V
Power Good threshold (Vout rising)	V <sub>PG4</sub>		93		%
Output under voltage lockout (Vout falling)	V <sub>UV4</sub>		85		%
Output over voltage lockout (Vout rising)	V <sub>OV4</sub>		117		%
Load Regulation, I <sub>OUT4</sub> = 100mA to 2.5A			1		%/A
Line Regulation, V <sub>CC4</sub> = 3 to 5V, I <sub>OUT4</sub> = 0.5A			0.1		%/V
Rated output current(If I <sub>CL4</sub> =3.5A)	I <sub>MAX4</sub>		2.5		A
Switch Current Limit (2A~3.5A programmable, step=0.5A)	I <sub>CL4</sub>		3.5		A
Operating Quiescent Current, No load, V <sub>DD</sub> =3.8V	I <sub>Q4</sub>		70		uA
Minimun Switch Current Limit (50mA~400mA programmable, step=50mA)	I <sub>CLMIN4</sub>		100		mA
Soft-start Time	t <sub>SS4</sub>		400		us
C <sub>OUT</sub> Discharge Switch ON Resistance	R <sub>DIS4</sub>		400		Ohm
Conversion Effeiciency, (DCR<50mohm) Vin=3.8V,Vout=3V					%
lout=2.5A			85		
lout=2A			89		
lout=1 .5A			91		
lout=1 A			94		
lout=500mA			95		
lout=100mA			92		
lout=10mA			60		
<b>CH6 LDO1</b>					
Input supply voltage range	V <sub>INPUT6</sub>	2.7		5.5	V
V <sub>OUT</sub> Output Voltage Adjustable Range, 4bit(step=100mv)	V <sub>OUT6</sub>	1.8		3.4	V
V <sub>OUT</sub> Output Voltage, Default( T <sub>j</sub> =25°C )	V <sub>OUT6(Default)</sub>	3.234	3.300	3.366	V



Parameter	Symbol	Min.	Typ.	Max.	Unit
V <sub>OUT</sub> Output Voltage, Default( T <sub>j</sub> = -10~85°C )	V <sub>OUT6(Default)</sub>	3.201	3.300	3.399	V
Power Good threshold (Vout rising)	V <sub>PG6</sub>		93		%
Output under voltage lockout (Vout falling)	V <sub>UV6</sub>		85		%
V <sub>OUT</sub> Load Regulation, I <sub>OUT</sub> = 1mA to 150mA			0.005		%/mA
V <sub>OUT</sub> Line Regulation, V <sub>IN6</sub> = 3 to 5V, I <sub>OUT6</sub> = 0.1A			0.03		%/V
Power Supply Reject Ratio (f = 10kHz, V <sub>OUT6</sub> =3.3V)	PSRR6		50		dB
Output noise (10Hz to 100kHz, V <sub>OUT6</sub> =3.3V)	OUT <sub>NOISE6</sub>		300		uVrms
Dropout voltage @ 150mA (V <sub>OUT6</sub> =3.3V)	V <sub>DROP6</sub>		200		mV
Rated output current	I <sub>MAX6</sub>		150		mA
Operating Quiescent Current, No load, V <sub>DD</sub> =3.8V	I <sub>Q6</sub>		28		uA
Current Limit, V <sub>OUT6</sub> = V <sub>OUT6</sub> x 0.95	I <sub>CL6</sub>	250	300		mA
Soft-start Time	t <sub>SS6</sub>		400		us
C <sub>OUT</sub> Discharge Switch ON Resistance	R <sub>DIS6</sub>		400		ohm
<b>CH7 LDO2</b>					
Input supply voltage range	V <sub>INPUT7</sub>	2.7		5.5	V
V <sub>OUT</sub> Output Voltage Adjustable Range, 4bit(step=100mv)	V <sub>OUT7</sub>	1.8		3.4	V
V <sub>OUT</sub> Output Voltage, Default( T <sub>j</sub> =25°C )	V <sub>OUT7(Default)</sub>	3.234	3.300	3.366	V
V <sub>OUT</sub> Output Voltage, Default( T <sub>j</sub> =-10~85°C )	V <sub>OUT7(Default)</sub>	3.201	3.300	3.399	V
Power Good threshold (Vout rising)	V <sub>PG7</sub>		93		%
Output under voltage lockout (Vout falling)	V <sub>UV7</sub>		85		%
V <sub>OUT</sub> Load Regulation, I <sub>OUT</sub> = 1mA to 150mA			0.005		%/mA
V <sub>OUT</sub> Line Regulation, V <sub>IN7</sub> = 3 to 5V, I <sub>OUT7</sub> = 0.1A			0.03		%/V
Power Supply Reject Ratio (f = 10kHz, V <sub>OUT7</sub> =3.3V)	PSRR7		50		dB
Output noise (10Hz to 100kHz, V <sub>OUT7</sub> =3.3V)	OUT <sub>NOISE7</sub>		300		uVrms
Dropout voltage @ 150mA (V <sub>OUT7</sub> =3.3V)	V <sub>DROP7</sub>		200		mV
Operating Quiescent Current, No load, V <sub>DD</sub> =3.8V	I <sub>Q7</sub>		28		uA
Rated output current	I <sub>MAX7</sub>		150		mA
Current Limit, V <sub>OUT7</sub> = V <sub>OUT7</sub> x 0.95	I <sub>CL7</sub>	250	300		mA
Soft-start Time	t <sub>SS7</sub>		400		us
C <sub>OUT</sub> Discharge Switch ON Resistance	R <sub>DIS7</sub>		400		Ohm
<b>CH8 LDO3</b>					
Input supply voltage range	V <sub>INPUT7</sub>	2.7		5.5	V
V <sub>OUT</sub> Output Voltage Adjustable Range, 4bit (0.8V~2V, step=100mV, 2V~ 2.5V step=500mV)	V <sub>OUT8</sub>	0.8		2.5	V
V <sub>OUT</sub> Output Voltage, Default( T <sub>j</sub> =25°C )	V <sub>OUT8(Default)</sub>	1.078	1.100	1.122	V
V <sub>OUT</sub> Output Voltage, Default( T <sub>j</sub> =-10~85°C )	V <sub>OUT8 (Default)</sub>	1.067	1.100	1.133	V

Parameter	Symbol	Min.	Typ.	Max.	Unit
Power Good threshold (Vout rising)	V <sub>PG8</sub>		93		%
Output under voltage lockout (Vout falling)	V <sub>UV8</sub>		85		%
V <sub>OUT</sub> Load Regulation, I <sub>OUT</sub> = 1mA to 150mA			0.006		%/mA
V <sub>OUT</sub> Line Regulation, V <sub>IN8</sub> = 3 to 5V, I <sub>OUT8</sub> = 0.05A			0.015		%/V
Power Supply Reject Ratio (f = 10kHz, V <sub>OUT8</sub> =1.1V)	PSRR8		70		dB
Output noise (10Hz to 100kHz, V <sub>OUT8</sub> =1.1V)	OUT <sub>NOISE8</sub>		30		uVrms
Dropout voltage @ 100mA (V <sub>OUT8</sub> =2.5V)	V <sub>DROP8</sub>		200		mV
Rated output current	I <sub>MAX8</sub>		100		mA
Operating Quiescent Current, No load, V <sub>DD</sub> =3.8V	I <sub>Q8</sub>		52		uA
Current Limit, V <sub>OUT8</sub> = V <sub>OUT8</sub> x 0.95	I <sub>CL8</sub>	150	200		mA
Soft-start Time	t <sub>SS8</sub>		400		us
C <sub>OUT</sub> Discharge Switch ON Resistance	R <sub>DIS8</sub>		400		Ohm
<b>CH9 LDO4</b>					
Input supply voltage range	V <sub>INPUT9</sub>	2.7		5.5	V
V <sub>OUT</sub> Output Voltage Adjustable Range, 4bit(step=100mv)	V <sub>OUT9</sub>	1.8		3.4	V
V <sub>OUT</sub> Output Voltage, Default( T <sub>j</sub> =25°C )	V <sub>OUT9(Default)</sub>	2.450	2.500	2.550	V
V <sub>OUT</sub> Output Voltage, Default( T <sub>j</sub> =-10~85°C )	V <sub>OUT9(Default)</sub>	2.425	2.500	2.575	V
Power Good threshold (Vout rising)	V <sub>PG9</sub>		93		%
Output under voltage lockout (Vout falling)	V <sub>UV9</sub>		85		%
V <sub>OUT</sub> Load Regulation, I <sub>OUT</sub> = 1mA to 150mA			0.005		%/mA
V <sub>OUT</sub> Line Regulation, V <sub>IN9</sub> = 3 to 5V, I <sub>OUT9</sub> = 0.15A			0.03		%/V
Power Supply Reject Ratio (f = 10kHz, V <sub>OUT9</sub> =3.3V)	PSRR9		50		dB
Output noise (10Hz to 100kHz, V <sub>OUT9</sub> =3.3V)	OUT <sub>NOISE9</sub>		300		uVrms
Dropout voltage @ 150mA (V <sub>OUT9</sub> =3.3V)	V <sub>DROP9</sub>		200		mV
Operating Quiescent Current, No load, V <sub>DD</sub> =3.8V	I <sub>Q9</sub>		28		uA
Rated output current	I <sub>MAX9</sub>		150		mA
Current Limit, V <sub>OUT9</sub> = V <sub>OUT9</sub> x 0.95	I <sub>CL9</sub>	250	300		mA
Soft-start Time	t <sub>SS9</sub>		400		us
C <sub>OUT</sub> Discharge Switch ON Resistance	R <sub>DIS9</sub>		400		Ohm
<b>CH10 LDO5</b>					
Input supply voltage range	V <sub>INPUT10</sub>	2.7		5.5	V
V <sub>OUT</sub> Output Voltage Adjustable Range, 4bit(step=100mv)	V <sub>OUT10</sub>	1.8		3.4	V
V <sub>OUT</sub> Output Voltage, Default( T <sub>j</sub> =25°C )	V <sub>OUT10(Default)</sub>	2.744	2.800	2.856	V
V <sub>OUT</sub> Output Voltage, Default( T <sub>j</sub> =-10~85°C )	V <sub>OUT10(Default)</sub>	2.716	2.800	2.884	V
Power Good threshold (Vout rising)	V <sub>PG10</sub>		93		%
Output under voltage lockout (Vout falling)	V <sub>UV10</sub>		85		%
V <sub>OUT</sub> Load Regulation, I <sub>OUT</sub> = 1mA to 300mA			0.003		%/mA

Parameter	Symbol	Min.	Typ.	Max.	Unit
V <sub>OUT</sub> Line Regulation, V <sub>IN10</sub> = 3 to 5V, I <sub>OUT10</sub> = 0.3A			0.01		%/V
Power Supply Reject Ratio (f = 10kHz, V <sub>OUT10</sub> =3.3V)	PSRR10		52		dB
Output noise (10Hz to 100kHz, V <sub>OUT10</sub> =3.3V)	OUT <sub>NOISE10</sub>		300		uVrms
Dropout voltage @ 300mA (V <sub>OUT10</sub> =2.8V)	V <sub>DROP10</sub>		200		mV
Operating Quiescent Current, No load, V <sub>DD</sub> =3.8V	I <sub>Q10</sub>		28		uA
Rated output current	I <sub>MAX10</sub>		300		mA
Current Limit, V <sub>OUT10</sub> = V <sub>OUT10</sub> x 0.95	I <sub>CL10</sub>	350	500		mA
Soft-start Time	t <sub>SS10</sub>		400		us
C <sub>OUT</sub> Discharge Switch ON Resistance	R <sub>DIS10</sub>		400		Ohm
<b>CH11 LDO6</b>					
Input supply voltage range	V <sub>INPUT11</sub>	2.7		5.5	V
V <sub>OUT</sub> Output Voltage Adjustable Range, 5bit(step=100mv)	V <sub>OUT11</sub>	0.8		2.5	V
V <sub>OUT</sub> Output Voltage, Default( T <sub>j</sub> =25°C )	V <sub>OUT11</sub> (Default)	1.176	1.200	1.224	V
V <sub>OUT</sub> Output Voltage, Default( T <sub>j</sub> =-10~85°C )	V <sub>OUT11</sub> (Default)	1.164	1.200	1.236	V
Power Good threshold (Vout rising)	V <sub>PG11</sub>		93		%
Output under voltage lockout (Vout falling)	V <sub>UV11</sub>		85		%
V <sub>OUT</sub> Load Regulation, I <sub>OUT</sub> = 1mA to 150mA			0.005		%/mA
V <sub>OUT</sub> Line Regulation, V <sub>IN11</sub> = 3 to 5V, I <sub>OUT11</sub> = 0.1A			0.015		%/V
Power Supply Reject Ratio (f = 10kHz, V <sub>OUT11</sub> =3.3V)	PSRR11		70		dB
Output noise (10Hz to 100kHz, V <sub>OUT11</sub> =3.3V)	OUT <sub>NOISE11</sub>		30		uVrms
Dropout voltage @ 150mA (V <sub>OUT11</sub> =2.5V)	V <sub>DROP11</sub>		500		mV
Operating Quiescent Current, No load, V <sub>DD</sub> =3.8V	I <sub>Q11</sub>		52		uA
Rated output current	I <sub>MAX11</sub>		150		mA
Current Limit, V <sub>OUT11</sub> = V <sub>OUT11</sub> x 0.95	I <sub>CL11</sub>	200	300		mA
Soft-start Time	t <sub>SS11</sub>		400		us
C <sub>OUT</sub> Discharge Switch ON Resistance	R <sub>DIS11</sub>		400		Ohm
<b>CH12 LDO7</b>					
Input supply voltage range	V <sub>INPUT12</sub>	2.7		5.5	V
V <sub>OUT</sub> Output Voltage Adjustable Range, 5bit(step=100mv)	V <sub>OUT12</sub>	0.8		2.5	V
V <sub>OUT</sub> Output Voltage, Default( T <sub>j</sub> =25°C )	V <sub>OUT12</sub> (Default)	1.764	1.800	1.836	V
V <sub>OUT</sub> Output Voltage, Default( T <sub>j</sub> =-10~85°C )	V <sub>OUT12</sub> (Default)	-1.736	1.800	1.854	V
Power Good threshold (Vout rising)	V <sub>PG12</sub>		93		%
Output under voltage lockout (Vout falling)	V <sub>UV12</sub>		85		%
V <sub>OUT</sub> Load Regulation, I <sub>OUT</sub> = 1mA to 300mA			0.005		%/mA
V <sub>OUT</sub> Line Regulation, V <sub>IN12</sub> = 3 to 5V, I <sub>OUT12</sub> = 0.3A			0.015		%/V
Power Supply Reject Ratio (f = 10kHz,	PSRR12		65		dB

Parameter	Symbol	Min.	Typ.	Max.	Unit
<b>V<sub>OUT12</sub>=3.3V</b>					
Output noise (10Hz to 100kHz, V <sub>OUT12</sub> =3.3V)	OUT <sub>NOISE12</sub>		50		uVrms
Dropout voltage @ 300mA (V <sub>OUT12</sub> =2.5V)	V <sub>DROP12</sub>		200		mV
Operating Quiescent Current, No load, V <sub>DD</sub> =3.8V	I <sub>Q12</sub>		48		uA
Rated output current	I <sub>MAX12</sub>		300		mA
Current Limit, V <sub>OUT12</sub> = V <sub>OUT12</sub> x 0.95	I <sub>CL12</sub>	400	400		mA
Soft-start Time	t <sub>SS12</sub>		400		us
C <sub>OUT</sub> Discharge Switch ON Resistance	R <sub>DIS12</sub>		400		Ohm
<b>CH13 LDO8</b>					
Input supply voltage range	V <sub>INPUT13</sub>	2.7		5.5	V
V <sub>OUT</sub> Output Voltage Adjustable Range, 4bit(step=100mv)	V <sub>OUT13</sub>	1.8		3.4	V
V <sub>OUT</sub> Output Voltage, Default( T <sub>j</sub> =25°C )	V <sub>OUT13(Default)</sub>	3.234	3.300	3.366	V
V <sub>OUT</sub> Output Voltage, Default( T <sub>j</sub> =-10~85°C )	V <sub>OUT13(Default)</sub>	3.201	3.300	3.399	V
Power Good threshold (Vout rising)	V <sub>PG13</sub>		93		%
Output under voltage lockout (Vout falling)	V <sub>UV13</sub>		85		%
V <sub>OUT</sub> Load Regulation, I <sub>OUT</sub> = 1mA to 150mA			0.003		%/mA
V <sub>OUT</sub> Line Regulation, V <sub>IN13</sub> = 3 to 5V, I <sub>OUT6</sub> = 0.15A			0.01		%/V
Power Supply Reject Ratio (f = 10kHz, V <sub>OUT13</sub> =3.3V)	PSRR13		50		dB
Output noise (10Hz to 100kHz, V <sub>OUT13</sub> =3.3V)	OUT <sub>NOISE13</sub>		300		uVrms
Dropout voltage @ 300mA (V <sub>OUT13</sub> =2.8V)	V <sub>DROP13</sub>		200		mV
Operating Quiescent Current, No load, V <sub>DD</sub> =3.8V	I <sub>Q13</sub>		30		uA
Rated output current	I <sub>MAX13</sub>		300		mA
Current Limit, V <sub>OUT13</sub> = V <sub>OUT13</sub> x 0.95	I <sub>CL13</sub>	400	500		mA
Soft-start Time	t <sub>SS13</sub>		400		us
C <sub>OUT</sub> Discharge Switch ON Resistance	R <sub>DIS13</sub>		400		Ohm
<b>CH14 SWITCH1</b>					
Input supply voltage range	V <sub>INPUT14</sub>	2.7		5.5	V
Rated output current	I <sub>MAX14</sub>		300		mA
On resistance( V <sub>gs</sub> =3V)			200		mohm
Current Limit	I <sub>CL14</sub>	400	500		mA
C <sub>OUT</sub> Discharge Switch ON Resistance	R <sub>DIS14</sub>		400		Ohm
<b>CH15 SWITCH2</b>					
Input supply voltage range	V <sub>INPUT15</sub>	2.7		5.5	V
Rated output current	I <sub>MAX15</sub>		300		mA
On resistance( V <sub>gs</sub> =3V)			200		mohm
Current Limit	I <sub>CL15</sub>	400	500		mA
C <sub>OUT</sub> Discharge Switch ON Resistance	R <sub>DIS15</sub>		400		Ohm
<b>Real Time Clock (RTC)</b>					

Parameter	Symbol	Min.	Typ.	Max.	Unit
RTC Operating Voltage Range	$V_{IN}$	2.5		5.5	V
CLK32OUT1 jitter (open drain) (always on)		-25		+25	ns
CLK32OUT1 duty cycle		40		60	%
CLK32OUT2 jitter (open drain)		-25		+25	ns
CLK32OUT2 duty cycle		40		60	%
<b>I2C Interface TIMING SPECIFICATIONS (7-bits Slave address: 0011011)</b>					
SCL clock frequency	$f_{SCL}$			400	kHz
SCL high time	$t_{HIGH}$	0.6			us
SCL low time	$t_{LOW}$	1.3			us
Data setup time	$t_{SU,DAT}$	0.1			us
Data hold time	$t_{HD,DAT1}$	0.3			us
Setup time for repeated start	$t_{SU,STA}$	0.6			us
HOLD time for start/repeated start	$t_{HD,STA}$	0.6			us
Rise time of SCL/SDA, $C_B = 400pF$	$t_r$			300	ns
Fall width of SCL/SDA, $C_B = 400pF$	$t_f$			300	ns
Pulse width of suppressed spike	$t_{SP}$		50		ns
Capacitive load for each of bus line	$C_B$			400	pF

## Chapter 4 Function Description

### 4.1 State Machine Description

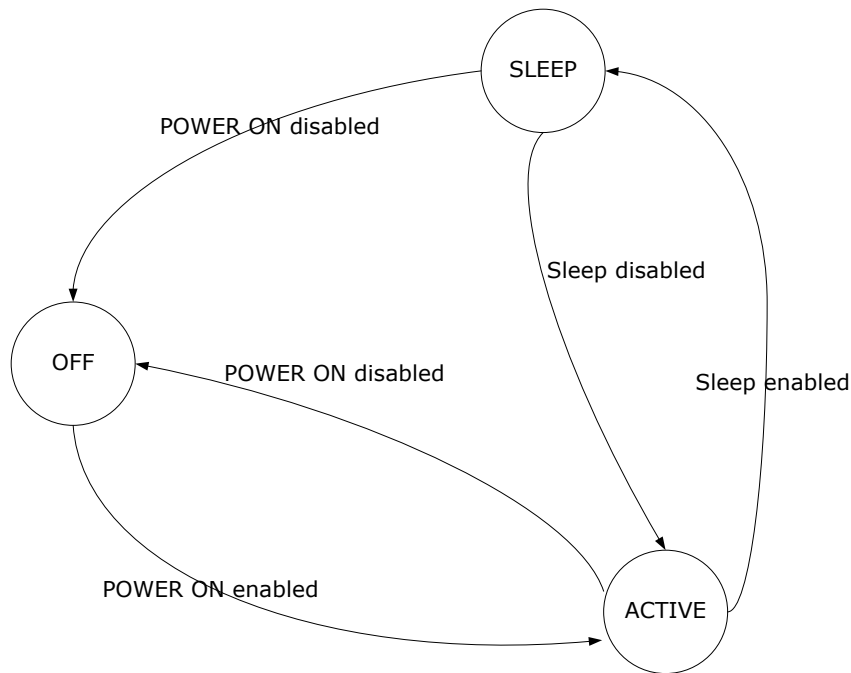

Fig. 4-1 State Machine

### 4.2 Device Power on Enable Conditions

- If none of the device power-on disable conditions is met, the following conditions are available to turn on and/or maintain the ON state of the device:
  - PWRON signal low level.
  - Or interrupt flag active (INT low) while the device is off (NRESPWRON = 0)
  - The power-on enable condition occurs only if the interrupt status bit is initially low (no previous identical interrupt pending in the status register).
- The Interrupt sources expected when the device is off are:
  - PWRON low-level interrupt (PWRON\_INT = 1 in INT\_STS\_REG1 register)
  - First VDC rising above plug-in threshold (PLUG\_IN interrupt(PLUG\_IN\_INT=1 in INT\_STS\_REG2 register) (Charger plug in interrupt)
- The Interrupt source expected if enabled when the device is off is:
  - RTC Alarm interrupt (INT\_ALARM\_EN=1 in RTC\_INT\_REG and RTC\_ALARM\_INT = 1 in INT\_STS\_REG register)

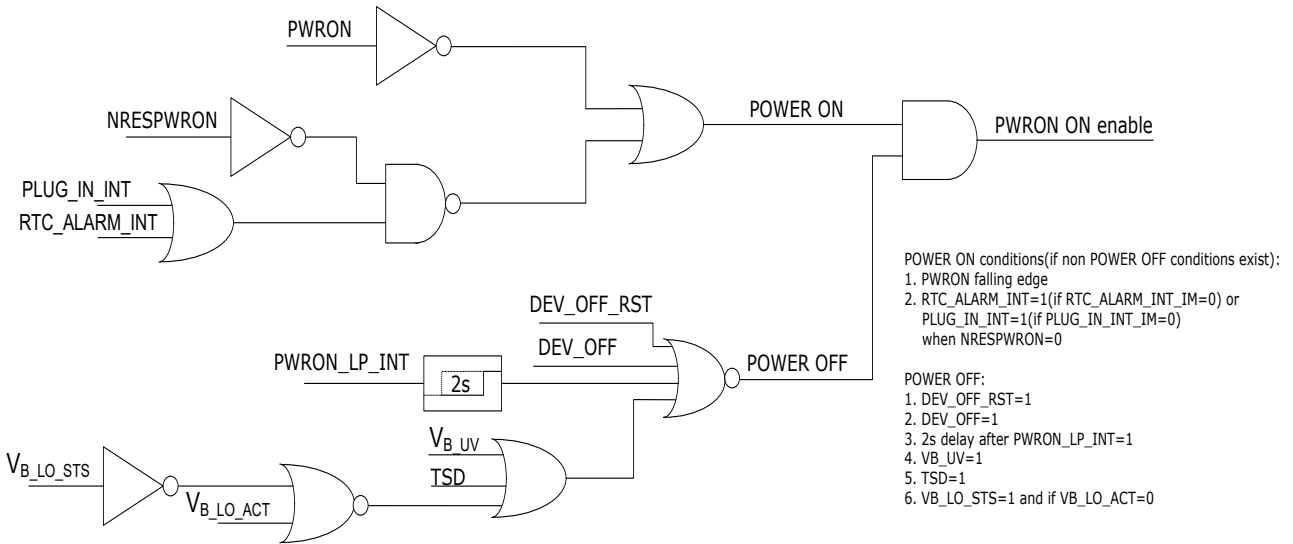

Fig. 4-2 Power On Enable Control

### 4.3 Device Power on Disable Conditions

- PWRON signal low level during more than the long-press delay: TDPWRONLPP. The interrupt corresponding to this condition is PWRON\_LP\_INT in the INT\_STS\_REG register.
- Or Die temperature has reached the thermal shutdown threshold: TSD\_STS=1 in THERMAL\_REG).
- Or Vbat down below UVLO threshold: V\_B\_UV\_STS=1 in V\_B\_MON\_REG.
- Or DEV\_OFF control bit set to 1 (value of DEV\_OFF is cleared when the device is in OFF state).

### 4.4 Device Sleep Enable Conditions

- SLEEP signal high level.
- OR DEV\_SLP control bit set to 1
- And interrupt flag inactive (INT high): No non-masked interrupt pending

The SLEEP state can be controlled by programming DEV\_SLP and keeping the SLEEP state.

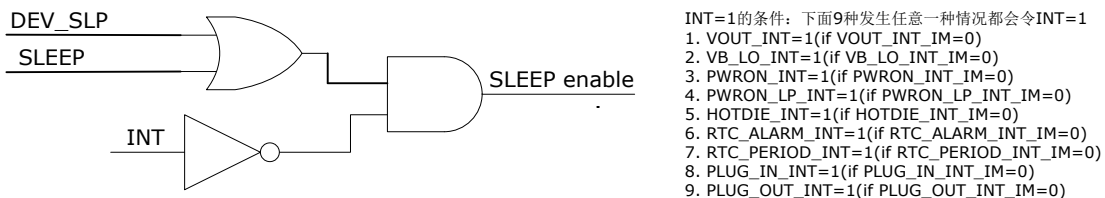

Fig. 4-3 SLEEP Enable Control

### 4.5 Power Sequence

Boot1/0	Power On Sequence		Prese t Voltage		Power On Sequence		Prese t Voltage		Power On Sequence					
	00	01	01	10	10	11	RK808-B		RK808-C		RK808-D		RK808-E	
	Seque nce	Typ Vout	Sequen ce	Typ Vout	Sequen ce	Typ Vout	Sequ ence	Typ Vout	Sequ ence	Typ Vout	Seque nce	Typ Vout	Sequence	Typ Vout
BUCK1	4	1.1V	4	1.2V	4	1.0V	2	1.1V	2	1.0V	4	0.9V	3	0.9V
BUCK2	5	1.1V	5	1.2V	4	1.0V	3	1.1V	3	1.0V	3	0.9V	5	0.9V
BUCK3	2	X*	2	X*	3	X*	3	X*	4	X*	2	X*	4	X*
BUCK4	1	3.0V	1	3.0V	1	3.0V	4	3.3V	6	1.8V	1	1.8V	2	1.8V
LDO1	OFF	3.3V	OFF	3.3V	1	3.3V	4	1.8V	7	3.3V	OFF	1.8V	8	3.0V
LDO2	OFF	3.3V	2	3.3V	OFF	3.3V	OFF	1.8V	OFF	1.8V	OFF	3.0V	OFF	3.0V
LDO3	3	1.1V	3	1.2V	2	1.0V	1	1.0V	1	1.0V	1	1.8V	1	0.9V
LDO4	3	2.5V	OFF	2.5V	2	1.8V	OFF	3.3V	OFF	3.3V	7	3.0V	2	1.8V
LDO5	OFF	2.8V	OFF	2.8V	OFF	2.8V	5	3.3V	OFF	3.3V	OFF	1.8V	2	1.8V
LDO6	OFF	1.2V	OFF	1.2V	OFF	1.2V	OFF	1.8V	OFF	1.8V	1	1.5V	2	1.5V
LDO7	OFF	1.8	OFF	1.8V	OFF	1.8V	3	1.8V	OFF	1.8V	OFF	1.8V	1	0.9V
LDO8	OFF	3.3V	OFF	1.8V	OFF	3.3V	OFF	3.3V	OFF	3.3V	5	3.0V	6	3.0V
SWITCH1	1	X	1	X	5	X	5	X	OFF	X	6	X	7	X
SWITCH2	OFF	X	OFF	X	OFF	X	OFF	X	OFF	X	OFF	X	OFF	X

Table 4-1 Power Start Up Sequence

The startup sequence of BOOT11 is the only difference between RK808-B, RK808-C, RK808-D and RK808-E.

X\*: The buck3 voltage is decided by external resistors.

X: it is related with input voltage of Switch1/2

4.5.1 BOOT1=0, BOOT0 = 0

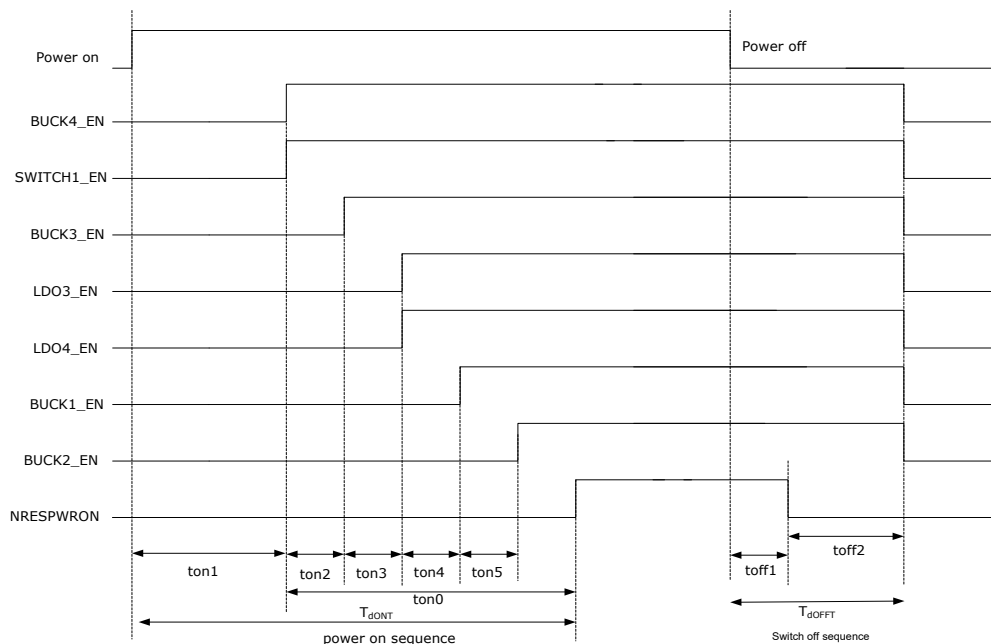

Fig. 4-4 Power On/Off Timing, BOOT1=0, BOOT0=0



**4.5.2 BOOT1=0, BOOT0 = 1**

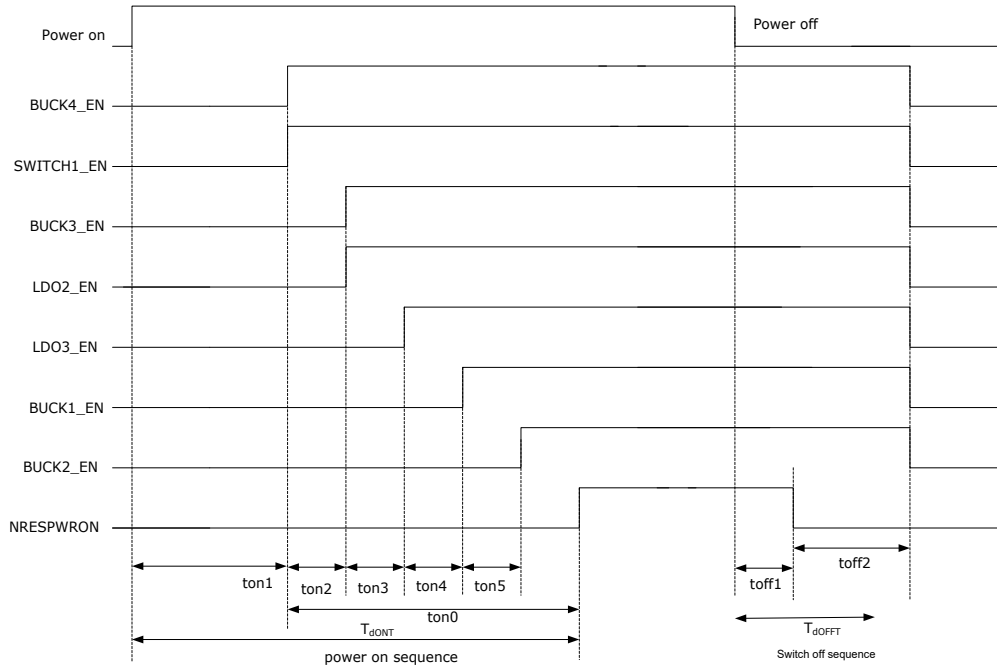

Fig. 4-5 Power On/Off Timing, BOOT1=0, BOOT0=1

**4.5.3 BOOT1=1, BOOT0 = 0**

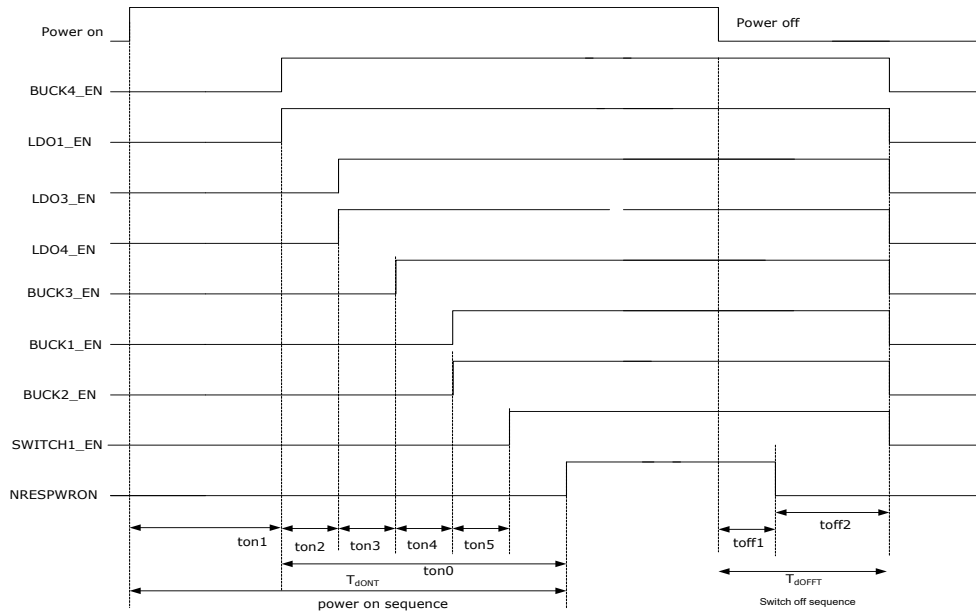

Fig. 4-6 Power On/Off Timing, BOOT1=1, BOOT0=0

**4.5.4 BOOT1=1, BOOT0 = 1(RK808-B/RK808-C/RK808-D/RK808-E, Programmed by OTP)**

**4.6 Boot Timing Characteristic**

PARAMETERS	DESCRIPTION	MIN	TYP	MAX	UNIT
ton1	Delay to 1st channel enable after power on delay time		2		ms
ton2	1st channel enable to 2nd channel enable delay		2		ms

PARAMETERS	DESCRIPTION	MIN	TYP	MAX	UNIT
ton3	2nd channel enable to 3rd channel enable delay		2		ms
ton4	3rd channel enable to 4th channel enable delay		2		ms
ton0	4rd channel enable to 5th channel enable delay		2		ms
ton5	5th channel enable to 6th channel enable delay		2		ms
Ton6	6th channel enable to 7th channel enable delay		2		ms
Ton7	7th channel enable to 8th channel enable delay		2		ms
Ton0	1st channel enable to NRESPWRON rising edge delay		82		ms
toff1	Power off to NRESPWRON falling delay		$1 \times t_{CK32K}$		us
Toff2	NRESPWRON falling delay to supplies disable delay		2		ms

Table 4-2 Boot Timing Characteristics

### 4.7 Device Turn on With PLUG\_IN

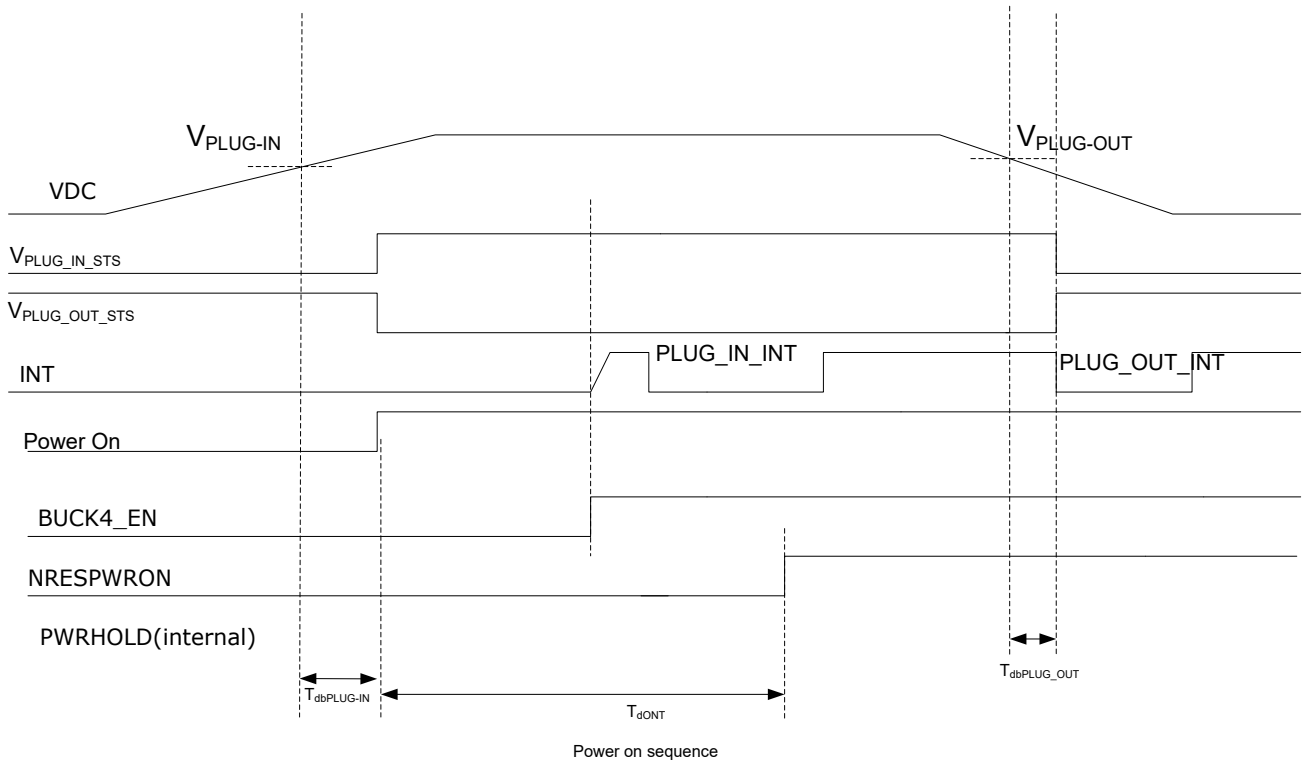

Fig. 4-7 Power ON Timing with VDC Plug in (PLUG\_IN\_INT Trigger a Power on Enable)

### 4.8 Device Turn off With Falling Input Voltage

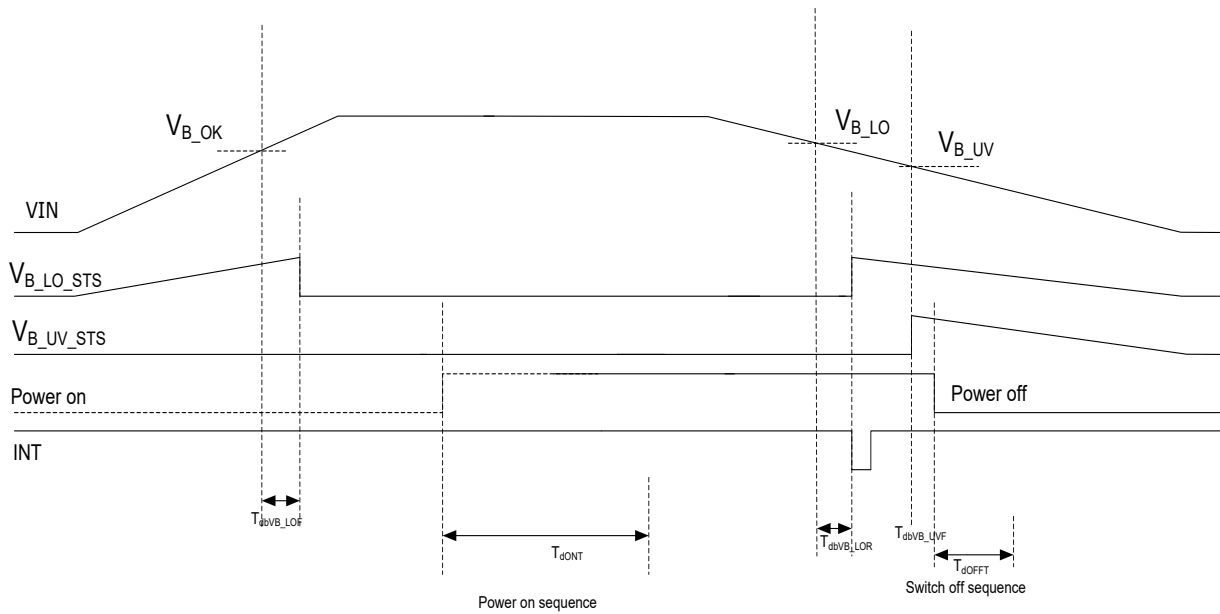

Fig. 4-8 Power Control Timing with VIN Falling

### 4.9 Timing Characteristics (Vin rising/falling and Plug-in)

PARAMETER	DESCRIPTION	MIN	TYP	MAX	UNIT
TdbVB_LOF	VB_LO falling-edge debouncing delay		2		ms
TdONT	Total power on delay time(ton1~ton6)		62		ms
TdbVB_LOR	VB_LO rising-edge debouncing delay		2		ms
TdVB_UVF	VB_UV falling-edge debouncing delay		2		ms
TdOFFT	Total power off delay time		2		ms
TdbPLUG_IN	VDC plug-in debouncing delay		100		ms
TdbPLUG_OUT	VDC plug-out debouncing delay		100		ms

Table 4-3 Vin and PLUG\_IN Timing Characteristics

### 4.10 Device State Control Through PWRON Signal

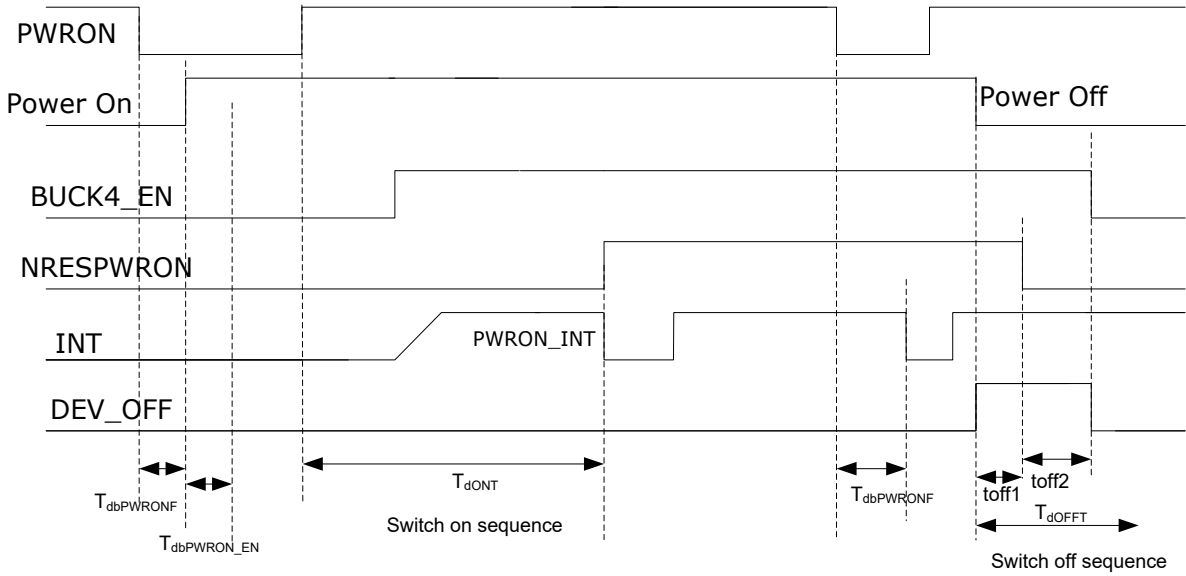

Fig. 4-9 PWRON Turn-On/DEV\_OFF Turn Off

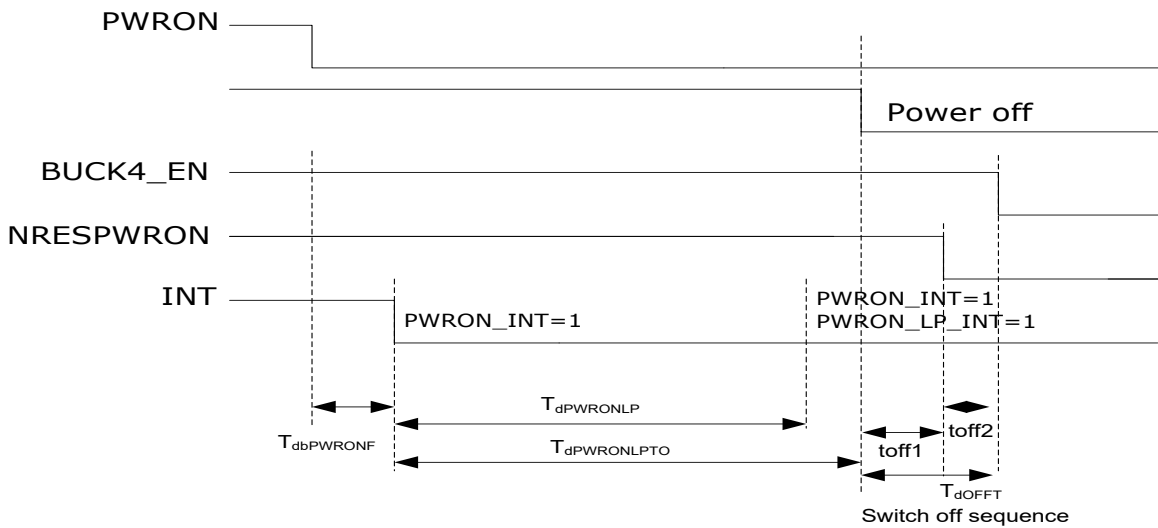

Fig. 4-10 PWRON Long Press Turn Off

### 4.11 Timing Characteristics (PWRON, DEV\_OFF)

PARAMETER	DESCRIPTION	MIN	TYP	MAX	UNIT
$T_{dbPWRONF}$	PWRON falling-edge debouncing delay		500		ms
$T_{dONT}$	Total power on delay time(ton1~ton6)		62		ms
$T_{dPWRONLP}$	PWRON long press delay to interrupt (PWRON falling edge to PWRON_LP_INT=1)		6		s
$T_{dPWRONLPTO}$	PWRON long press delay to turn off (PWRON falling edge to NRESPWRON falling edge)		8		s
toff1	POWER ON disable to NRESPWRON falling delay		$1 \times t_{CK32K}$		us

PARAMETER	DESCRIPTION	MIN	TYP	MAX	UNIT
T <sub>off2</sub>	NRESPWRON falling delay to supplies disable delay		2		ms
T <sub>dOFFT</sub>	total power off delay time		2		ms

Table 4-4 PWRON/DEV\_OFF Timing Characteristics

### 4.12 Device Sleep State Control

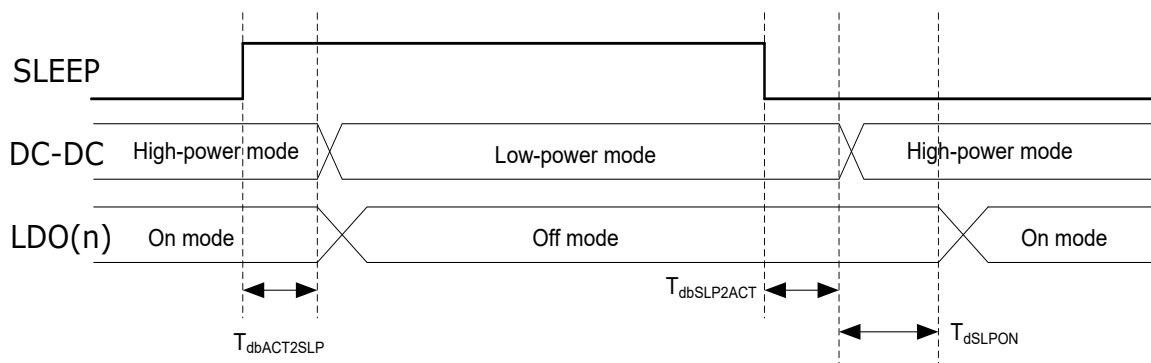

Fig. 4-11 SLEEP/ACTIVE Transition Timing

### 4.13 Timing Characteristics (SLEEP)

PARAMETER	DESCRIPTION	MIN	TYP	MAX	UNIT
T <sub>dbACT2SLP</sub>	SLEEP falling-edge debouncing delay		3×t <sub>ck32k</sub>		US
T <sub>dbSLP2ACT</sub>	SLEEP rising-edge debouncing delay		3×t <sub>ck32k</sub>		US
T <sub>dSLPON</sub>	Delay to turn on enable after SLEEP rising-edge debouncing		1×t <sub>ck32k</sub>		US

Table 4-5 SLEEP Timing Characteristics

## Chapter 5 Register Description

### 5.1 Register Summary

HEX ADDRESS	ACTION/ DESCRIPTION	R/W	DEFAULT/ RESET
<b>RTC REGISTERS</b>			
00	SECONDS REG	RW	00
01	MINUTES REG	RW	50
02	HOURS REG	RW	08
03	DAYS_REG	RW	21
04	MONTHS_REG	RW	01
05	YEARS_REG	RW	13
06	WEEKS_REG	RW	01
08	ALARM_SECONDS_REG	RW	00
09	ALARM_MINUTES_REG	RW	00
0A	ALARM_HOURS_REG	RW	00
0B	ALARM_DAYS_REG	RW	01
0C	ALARM_MONTHS_REG	RW	01
0D	ALARM_YEARS_REG	RW	00
10	RTC_CTRL_REG	RW	00
11	RTC_STATUS_REG	RW	82
12	RTC_INT_REG	RW	00
13	RTC_COMP_LSB_REG	RW	00
14	RTC_COMP_MSB_REG	RW	00
<b>RESERVED REGISTERS</b>			
0E	RESERVED	RW	00
0F	RESERVED	RW	00
15	RESERVED	RW	00
16	RESERVED	RW	00
17	RESERVED	RW	00
18	RESERVED	RW	00
<b>MISC REGISTERS</b>			
20	CLK32KOUT_REG	RW	00
21	VB_MON_REG	RW	06
22	THERMAL_REG	RW	00
<b>POWER CHANNEL CONTROL/MONITOR REGISTERS</b>			
23	DCDC_EN_REG	RW	boot
24	LDO_EN_REG	RW	boot
25	SLEEP_SET_OFF_REG1	RW	00
26	SLEEP_SET_OFF_REG2	RW	00
27	DCDC_UV_STS_REG	RO	00
28	DCDC_UV_ACT_REG	RW	1F
29	LDO_UV_STS_REG	RO	00
2A	LDO_UV_ACT_REG	RW	FF

HEX ADDRESS	ACTION/ DESCRIPTION	R/W	DEFAULT/ RESET
2B	DCDC_PG_REG	RO	00
2C	LDO_PG_REG	RO	00
2D	VOUT_MON_TDB_REG	RW	02
POWER CHANNEL CONFIGURATION REGISTERS			
2E	BUCK1_CONFIG_REG	RW	01
2F	BUCK1_ON_VSEL	RW	boot
30	BUCK1_SLP_VSEL	RW	00
31	BUCK1_DVS_VSEL	RW	00
32	BUCK2_CONFIG_REG	RW	01
33	BUCK2_ON_VSEL	RW	boot
34	BUCK2_SLP_VSEL	RW	00
35	BUCK2_DVS_VSEL	RW	00
36	BUCK3_CONFIG_REG	RW	01
37	BUCK4_CONFIG_REG	RW	00
38	BUCK4_ON_VSEL	RW	boot
39	BUCK4_SLP_VSEL_REG	RW	00
90	DCDC_ILMAX_REG	RW	00
3B	LDO1_ON_VSEL_REG	RW	boot
3C	LDO1_SLP_VSEL_REG	RW	00
3D	LDO2_ON_VSEL_REG	RW	boot
3E	LDO2_SLP_VSEL_REG	RW	00
3F	LDO3_ON_VSEL_REG	RW	boot
40	LDO3_SLP_VSEL_REG	RW	00
41	LDO4_ON_VSEL_REG	RW	boot
42	LDO4_SLP_VSEL_REG	RW	00
43	LDO5_ON_VSEL_REG	RW	boot
44	LDO5_SLP_VSEL_REG	RW	00
45	LDO6_ON_VSEL_REG	RW	boot
46	LDO6_SLP_VSEL_REG	RW	00
47	LDO7_ON_VSEL_REG	RW	boot
48	LDO7_SLP_VSEL_REG	RW	00
49	LDO8_ON_VSEL_REG	RW	boot
4A	LDO8_SLP_VSEL_REG	RW	00
4B	DEVCTRL_REG	RW	00
INTERRUPT REGISTERS			
4C	INT_STS_REG1	RW	00
4D	INT_STS_MSK_REG1	RW	00
4E	INT_STS_REG2	RW	00
4F	INT_STS_MSK_REG2	RW	00
50	IO_POL_REG	RW	06

**NOTE:** Address 51h through 97h are for OTP registers. Customer's accessibility to those addresses is not allowed.

## 5.2 Register Description

### 5.2.1 RTC Registers

● **SECONDS\_REG : RTC SECOND Register**

Address: 00H				Type: RW				
Bit	Bit7	Bit6	Bit5	Bit4	Bit3	Bit2	Bit1	Bit0
SYMBOL	RESV	SEC1			SEC0			
Default	0	0	0	0	0	0	0	0

#### Description

- Bit 7 Reserved
- Bit 6-4 Set the second digit of the RTC seconds (0-5)
- Bit 3-0 Set the first digit of the RTC seconds (0-9)
- Note BCD coding from 00 - 59

● **MINUTES\_REG : RTC MINUTE Register**

Address: 01H				Type: RW				
Bit	Bit7	Bit6	Bit5	Bit4	Bit3	Bit2	Bit1	Bit0
SYMBOL	RESV	MIN1			MIN0			
Default	0	1	0	1	0	0	0	0

#### Description

- Bit 7 Reserved
- Bit 6-4 Set the second digit of the RTC minutes
- Bit 3-0 Set the first digit of the RTC minutes
- Note BCD coding from 00 - 59

● **HOURS\_REG : RTC HOUR Register**

Address: 02H				Type: RW				
Bit	Bit7	Bit6	Bit5	Bit4	Bit3	Bit2	Bit1	Bit0
SYMBOL	PM/AM	RESV	HOUR1		HOUR0			
Default	0	0	0	0	1	0	0	0

#### Description

- Bit 7 Set PM or AM: Only used in PM-AM mode, 1: PM. 0:AM.
- Bit 6 Reserved
- Bit 5-4 Set the second digit of the RTC hours
- Bit 3-0 Set the first digit of the RTC hours
- Note HOUR1/0 BCD coding from 0-11/23

● **DAYS\_REG : RTC DAY Register**

Address: 03H				Type: RW				
Bit	Bit7	Bit6	Bit5	Bit4	Bit3	Bit2	Bit1	Bit0
SYMBOL	RESV	RESV	DAY1		DAY0			
Default	0	0	1	0	0	0	0	1

#### Description

- Bit 7-6 Reserved



Bit 5-4 Set the second digit of the RTC days

Bit 3-0 Set the first digit of the RTC days

Note BCD coding from 01 - 28/29/30/31

● **MONTHS\_REG : RTC MONTH Register**

Address: 04H				Type: RW				
Bit	Bit7	Bit6	Bit5	Bit4	Bit3	Bit2	Bit1	Bit0
SYMBOL	RESV	RESV	RESV	MONTH1	MONTH0			
Default	0	0	0	0	0	0	0	1

**Description**

Bit 7-5 Reserved

Bit 4 Set the second digit of the RTC months

Bit 3-0 Set the first digit of the RTC months

Note BCD coding from 01 - 12

● **YEARS\_REG : RTC YEAR Register**

Address: 05H				Type: RW				
Bit	Bit7	Bit6	Bit5	Bit4	Bit3	Bit2	Bit1	Bit0
SYMBOL	YEAR1			YEAR0				
Default	0	0	0	1	0	0	1	1

**Description**

Bit 7-5 Set the second digit of the RTC years

Bit 3-0 Set the first digit of the RTC years

Note BCD coding from 00 - 99

● **WEEKS\_REG : RTC WEEK Register**

Address: 06H				Type: RW				
Bit	Bit7	Bit6	Bit5	Bit4	Bit3	Bit2	Bit1	Bit0
SYMBOL	RESV	RESV	RESV	RESV	RESV	WEEK		
Default	0	0	0	0	0	0	0	1

**Description**

Bit 7-3 Reserved

Bit 2-0 Set the RTC weeks

Note BCD coding from 1 - 7

● **ALARM\_SECONDS\_REG : RTC ALARM SECOND Register**

Address: 08H				Type: RW				
Bit	Bit7	Bit6	Bit5	Bit4	Bit3	Bit2	Bit1	Bit0
SYMBOL	RESV	ALARM_SEC1			ALARM_SEC0			
Default	0	0	0	0	0	0	0	0

**Description**

Bit 7 Reserved

Bit 6-4 Set the second digit of the RTC alarm seconds

Bit 3-0 Set the first digit of the RTC alarm seconds

Note BCD coding from 00 - 59

● **ALARM\_MINUTES\_REG : RTC ALARM MINUTE Register**

Address: 09H				Type: RW				
Bit	Bit7	Bit6	Bit5	Bit4	Bit3	Bit2	Bit1	Bit0
SYMBOL	RESV	ALARM_MIN1			ALARM_MIN0			
Default	0	0	0	0	0	0	0	0

**Description**

Bit 7 Reserved

Bit 6-4 Set the second digit of the RTC alarm minutes

Bit 3-0 Set the first digit of the RTC alarm minutes

Note BCD coding from 00 - 59

● **ALARM\_HOURS\_REG : RTC ALARM HOUR Register**

Address: 0AH				Type: RW				
Bit	Bit7	Bit6	Bit5	Bit4	Bit3	Bit2	Bit1	Bit0
SYMBOL	ALARM_PM_AM	RESV	ALARM_HOUR1	ALARM_HOUR0				
Default	0	0	0	0	0	0	0	0

**Description**

Bit 7 Set PM or AM: Only used in PM-AM mode, 1: PM. 0:AM.

Bit 6 Reserved

Bit 5-4 Set the second digit of the RTC alarm hours

Bit 3-0 Set the first digit of the RTC alarm hours

Note HOUR1/0 BCD coding from 0-11/23

● **ALARM\_DAYS\_REG : RTC ALARM DAY Register**

Address: 0BH				Type: RW				
Bit	Bit7	Bit6	Bit5	Bit4	Bit3	Bit2	Bit1	Bit0
SYMBOL	RESV	RESV	ALARM_DAY1	ALARM_DAY0				
Default	0	0	0	0	0	0	0	1

**Description**

Bit 7-6 Reserved

Bit 5-4 Set the second digit of the RTC alarm days

Bit 3-0 Set the first digit of the RTC alarm days

Note BCD coding from 01 - 28/29/30/31

● **ALARM\_MONTHS\_REG : RTC ALARM MONTH Register**

Address: 0CH				Type: RW				
Bit	Bit7	Bit6	Bit5	Bit4	Bit3	Bit2	Bit1	Bit0
SYMBOL	RESV	RESV	RESV	ALARM_MONTH1	ALARM_MONTH0			
Default	0	0	0	0	0	0	0	1

**Description**

- Bit 7-5 Reserved
- Bit 4 Set the second digit of the RTC alarm months
- Bit 3-0 Set the first digit of the RTC alarm months
- Note BCD coding from 01 - 12

● **ALARM\_YEARS\_REG : RTC ALARM YEAR Register**

Address: 0DH				Type: RW				
Bit	Bit7	Bit6	Bit5	Bit4	Bit3	Bit2	Bit1	Bit0
SYMBOL	ALARM_YEAR1			ALARM_YEAR0				
Default	0	0	0	0	0	0	0	0

**Description**

- Bit 7-4 Set the second digit of the RTC alarm years
- Bit 3-0 Set the first digit of the RTC alarm years
- Note BCD coding from 00 - 99

● **RTC\_CTRL\_REG : RTC Control Register**

Address: 10H				Type: RW				
Bit	Bit7	Bit6	Bit5	Bit4	Bit3	Bit2	Bit1	Bit0
SYMBOL	RTC_READ SEL	GET_TI ME	SET_32_ COUNTER	TEST_M ODE	AMPM_ MODE	AUTO_ COMP	ROUND_30S (Auto Clr)	STOP_ RTC
Default	0	0	0	0	0	0	0	0

**Description**

- Bit 7 RTC\_READSEL: 0: Read access directly to dynamic registers.  
1: Read access to static shadowed registers
- Bit 6 GET\_TIME: Rising transition of this register transfers dynamic registers into static shadowed registers.
- Bit 5 SET\_32\_COUNTER: 1: set the 32-kHz counter with COMP\_REG value. It must only be used when the RTC is frozen.
- Bit 4 TEST\_MODE: 1: test mode (Auto compensation is enable when the 32kHz counter reaches at its end)
- Bit 3 AMPM\_MODE: 0: 24 hours mode.  
1: 12 hours mode (PM-AM mode)
- Bit 2 AUTO\_COMP: 0: No auto compensation RW0.  
1: Auto compensation enabled
- Bit 1 ROUND\_30S: 1: When 1 is written, the time is rounded to the closest minute in next second. self cleared after rounding
- Bit 0 STOP\_RTC: 1: RTC is frozen.  
0: RTC is running.  
RTC\_time can only be changed during RTC frozen

● **RTC\_STATUS\_REG : RTC Status Register**

Address: 11H				Type: RW				
Bit	Bit7	Bit6	Bit5	Bit4	Bit3	Bit2	Bit1	Bit0
SYMBOL	POWER_UP (Write 1 Clr)	ALARM (Write 1 Clr)	EVENT_1D (Write 1 Clr)	EVENT_1H (Write 1 Clr)	EVENT_1M (Write 1 Clr)	EVENT_1S (Write 1 Clr)	RUN (RO)	RESV
Default	1	0	0	0	0	0	1	0

**Description**

- Bit 7 POWER\_UP: POWER\_UP is set by a reset, is cleared by writing one in this bit.
- Bit 6 ALARM: Indicates that an alarm interrupt has been generated (bit clear by writing 1) The alarm interrupt keeps its low level, until the micro-controller writes 1 in the ALARM bit of the RTC\_STATUS register.The timer interrupt is a low-level pulse (15 μs duration).
- Bit 5 EVENT\_1D: One day has occurred
- Bit 4 EVENT\_1H: One hour has occurred
- Bit 3 EVENT\_1M: One minute has occurred
- Bit 2 EVENT\_1S :One secondr has occurred
- Bit 1 RUN: 0, RTC is frozen. 1, RTC is running. This bit shows the real state of the RTC
- Bit 0 RESEVERED

● **RTC\_INT\_REG : RTC Interrupt Register**

Address: 12H				Type: RW				
Bit	Bit7	Bit6	Bit5	Bit4	Bit3	Bit2	Bit1	Bit0
SYMBOL	RESV	RESV	RESV	INT_SLEEP_MASK_EN	INT_ALARM_EN	INT_TIMER_EN	EVERY	
Default	0	0	0	0	0	0	0	0

**Description**

- Bit 7-5 RESEVERED
- Bit 4 INT\_SLEEP\_MASK\_EN:  
1: Mask periodic interrupt while the device is in SLEEP mode  
0: Normal mode, no interrupt masked.
- Bit 3 INT\_ALARM\_EN: Enable one interrupt when the alarm value is reached  
1: Enable  
0: Disable
- Bit 2 INT\_TIMER\_EN:Enable periodic interrupt  
1:Enable  
0:Disable
- Bit 1-0 EVERY: 00: every second 01: every minute 10: every hour 11: every day

● **RTC\_COMP\_LSB\_REG : RTC Comensation LSB Register**

Address: 13H				Type: RW				
--------------	--	--	--	----------	--	--	--	--

Bit	Bit7	Bit6	Bit5	Bit4	Bit3	Bit2	Bit1	Bit0
SYMBOL	RTC_COMP_LSB							
Default	0	0	0	0	0	0	0	0

**Description**

Bit7-0 This register contains the number of 32-kHz periods to be added into the 32KHz counter every hour [LSB]

● **RTC\_COMP\_MSB\_REG : RTC Compensation MSB Register**

Address: 14H				Type: RW				
Bit	Bit7	Bit6	Bit5	Bit4	Bit3	Bit2	Bit1	Bit0
SYMBOL	RTC_COMP_MSB							
Default	0	0	0	0	0	0	0	0

**Description**

Bit7-0 This register contains the number of 32-kHz periods to be added into the 32KHz counter every hour [MSB]

**5.2.2 MISC Registers**

● **CLK32KOUT\_REG : RTC Compensation MSB Register**

Address: 20H				Type: RW				
Bit	Bit7	Bit6	Bit5	Bit4	Bit3	Bit2	Bit1	Bit0
SYMBOL	RESERVED							CLK32KOUT2_EN
Default	0	0	0	0	0	0	0	0

**Description**

Bit 7-1 Reserved  
 Bit 0 CLK32KOUT2\_EN:  
 1. CLK32KOUT2 output is enabled  
 0. CLK32KOUT2 output is disabled

● **VB\_MON\_REG : Battery Voltage Monitor Register**

Address: 21H				Type: RW				
Bit	Bit7	Bit6	Bit5	Bit4	Bit3	Bit2	Bit1	Bit0
SYMBOL	PLUG_OUT_STS (RO)	PLUG_IN_STS (RO)	VB_UV_STS (RO)	VB_LO_ACT	VB_LO_STS (RO)	VB_LO_SEL		
Default	0	0	0	0	0	1	1	0

**Description**

Bit 7 PLUG\_OUT\_STS: charger plug-out event occurs(DC PIN voltage <3.5V)  
 0: no charger plug out  
 1: charger plugged out  
 This bit is read only  
 Bit 6 PLUG\_IN\_STS: charger plug-in event occurs(DC PIN voltage >3.8V)  
 0: no charger plug in

- 1: charger plugged in  
This bit is read only
- Bit 5 VB\_UV\_STS: Battery under voltage lockout status(shut down system if the bit=1)  
This bit is read only
- Bit 4 VB\_LO\_ACT: VBAT low action  
0: shut down system  
1: insert interrupt
- Bit 3 VB\_LO\_STS: Battery low voltage status  
0: VBAT>VB\_LO\_SEL  
1: VBAT<VB\_LO\_SEL  
This bit is read only
- Bit 2-0 VB\_LO\_SEL: Battery low voltage threshold  
000~111: 2.8V~ 3.5V, step=100mV

● **THERMAL\_REG : Thermal Control Register**

Address: 22H				Type: RW				
Bit	Bit7	Bit6	Bit5	Bit4	Bit3	Bit2	Bit1	Bit0
SYMBOL	RESV	RESV	RESV	TSD_T EMP	HOTDIE_TEMP		HOTDIE_STS (RO)	TSD_STS (RO)
Default	0	0	0	0	0	0	0	0

**Description**

- Bit 7-5 Reserved
- Bit 4 TSD\_TEMP: Thermal shutdown temperture threshold  
0: 140℃;  
1: 170℃
- Bit 3-2 HOTDIE\_TEMP: Hot-die temperature threshold  
00: 85℃;  
01: 95℃;  
10: 105℃;  
11: 115℃
- Bit 1 HOTDIE\_STS: Hot-die warning  
This bit is read only bit.
- Bit 0 TSD\_STS: Thermal shut down

**5.2.3 Power Channel Control/Monitor Registers**

● **DCDC\_EN\_REG : DC-DC Converter Enable Register**

Address: 23H				Type: RW				
Bit	Bit7	Bit6	Bit5	Bit4	Bit3	Bit2	Bit1	Bit0
SYMBOL	RESV	SWITC H2_EN	SWITC H1_EN	RESV	BUCK4 _EN	BUCK3 _EN	BUCK2 _EN	BUCK1 _EN
Default	Boot							

**Description**

- Bit 7 Reserved

- Bit 6-5 SWITCH(n): SWITCH1 and SWITCH2 enable  
1, Enable  
0, Disable  
The default value is set by boot.
- Bit 4 Reserved
- Bit 3-0 BUCK(n)\_EN: BUCKn enable  
1, Enable  
0, Disable  
The default value is set by boot.

● **LDO\_EN\_REG : LDO Enable Register**

Address: 24H				Type: RW				
Bit	Bit7	Bit6	Bit5	Bit4	Bit3	Bit2	Bit1	Bit0
SYMBOL	LDO8_ EN	LDO7_ EN	LDO6_ EN	LDO5_ EN	LDO4_ EN	LDO3_ EN	LDO2_ EN	LDO1_ EN
Default	Boot							

**Description**

- Bit 7-0 LDO(n): LDO(n) enable  
1, Enable  
0, Disable  
The default value is set by boot.

● **SLEEP\_SET\_OFF\_REG1 : Sleep set Off Register #1**

Address: 25H				Type: RW				
Bit	Bit7	Bit6	Bit5	Bit4	Bit3	Bit2	Bit1	Bit0
SYMBOL	RESV	SWITCH2_ SLP_SET_ OFF	SWITCH1_ SLP_SET_ OFF	RESV	BUCK4_S LP_SET_O FF	BUCK3_S LP_SET_O FF	BUCK2_S LP_SET_O FF	BUCK1_ SLP_SE T_OFF
Default	0	0	0	0	0	0	0	0

**Description**

- Bit 7 Reserved
- Bit 6 1: Switch2 is set off in sleep mode  
0: Switch2 is enable in sleep mode
- Bit 5 1: Switch1 is set off in sleep mode  
0: Switch1 is enable in sleep mode
- Bit 4 Reserved
- Bit 3 1: Buck4 is set off in sleep mode  
0: Buck4 is enable in sleep mode
- Bit 2 1: Buck3 is set off in sleep mode  
0: Buck3 is enable in sleep mode
- Bit 1 1: Buck2 is set off in sleep mode  
0: Buck2 is enable in sleep mode

Bit 0 1: Buck1 is set off in sleep mode  
 0: Buck1 is enable in sleep mode

● **SLEEP\_SET\_OFF\_REG2 : Sleep set Off Register #2**

Address: 26H				Type: RW				
Bit	Bit7	Bit6	Bit5	Bit4	Bit3	Bit2	Bit1	Bit0
SYMBOL	LDO8_S LP_SET_ OFF	LDO7_S LP_SET_ OFF	LDO6_S LP_SET_ OFF	LDO5_S LP_SET_ OFF	LDO4_S LP_SET_ OFF	LDO3_S LP_SET_ OFF	LDO2_S LP_SET_ OFF	LDO1_S LP_SET_ OFF
Default	0	0	0	0	0	0	0	0

**Description**

Bit 7 1: LDO8 is set off in sleep mode  
 0: LDO8 is enable in sleep mode  
 Bit 6 1: LDO7 is set off in sleep mode  
 0: LDO7 is enable in sleep mode  
 Bit 5 1: LDO6 is set off in sleep mode  
 0: LDO6 is enable in sleep mode  
 Bit 4 1: LDO5 is set off in sleep mode  
 0: LDO5 is enable in sleep mode  
 Bit 3 1: LDO4 is set off in sleep mode  
 0: LDO4 is enable in sleep mode  
 Bit 2 1: LDO3 is set off in sleep mode  
 0: LDO3 is enable in sleep mode  
 Bit 1 1: LDO2 is set off in sleep mode  
 0: LDO2 is enable in sleep mode  
 Bit 0 1: LDO1 is set off in sleep mode  
 0: LDO1 is enable in sleep mode

● **DCDC\_UV\_STS\_REG : DC-DC Under Voltage Status Register**

Address: 27H				Type: R				
Bit	Bit7	Bit6	Bit5	Bit4	Bit3	Bit2	Bit1	Bit0
SYMBOL	RESV	RESV	RESV	RESV	BUCK4_ UV_STS	BUCK3_ UV_STS	BUCK2_ UV_STS	BUCK1_ UV_STS
Default	0	0	0	0	0	0	0	0

**Description**

Bit 7-5 Reserved  
 Bit 4 Reserved  
 Bit 3 BUCK4\_UV\_STS: BUCK4 under voltage flag.  
 1: Output voltage drop below 85% of nominal voltage  
 0: Normal  
 Bit 2 BUCK3\_UV\_STS: BUCK3 under voltage flag.  
 1: Output voltage drop below 85% of nominal voltage  
 0: Normal  
 Bit 1 BUCK2\_UV\_STS: BUCK2 under voltage flag.  
 1: Output voltage drop below 85% of nominal voltage



- 0: Normal
- Bit 0 BUCK1\_UV\_STS: BUCK1 under voltage flag.
- 1: Output voltage drop below 85% of nominal voltage
- 0: Normal

● **DCDC\_UV\_ACT\_REG : DC-DC Under Voltage Action Register**

Address: 28H				Type: R				
Bit	Bit7	Bit6	Bit5	Bit4	Bit3	Bit2	Bit1	Bit0
SYMBOL	RESV	RESV	RESV	RESV	BUCK4_UV_ACT	BUCK3_UV_ACT	BUCK2_UV_ACT	BUCK1_UV_ACT
Default	0	0	0	1	1	1	1	1

**Description**

- Bit 7-5 Reserved
- Bit 4 Reserved
- Bit 3 BUCK4\_UV\_ACT: BUCK4 under voltage flag.  
1: restart converter  
0: No effect
- Bit 2 BUCK3\_UV\_ACT: BUCK3 under voltage flag.  
1: restart converter  
0: No effect
- Bit 1 BUCK2\_UV\_ACT: BUCK2 under voltage flag.  
1: restart converter  
0: No effect
- Bit 0 BUCK1\_UV\_ACT: BUCK1 under voltage flag.  
1: restart converter  
0: No effect

● **LDO\_UV\_STS\_REG : LDO Under Voltage Status Register**

Address: 29H				Type: R				
Bit	Bit7	Bit6	Bit5	Bit4	Bit3	Bit2	Bit1	Bit0
SYMBOL	LDO8_UV_STS	LDO7_UV_STS	LDO6_UV_STS	LDO5_UV_STS	LDO4_UV_STS	LDO3_UV_STS	LDO2_UV_STS	LDO1_UV_STS
Default	0	0	0	0	0	0	0	0

**Description**

- Bit 7 LDO8\_UV\_STS: LDO8 under voltage flag.  
1, Output voltage drop below 85% of nominal voltage  
0, Normal
- Bit 6 LDO7\_UV\_STS: LDO7 under voltage flag.  
1, Output voltage drop below 85% of nominal voltage  
0, Normal
- Bit 5 LDO6\_UV\_STS: LDO6 under voltage flag.  
1, Output voltage drop below 85% of nominal voltage  
0, Normal
- Bit 4 LDO5\_UV\_STS: LDO5 under voltage flag.  
1, Output voltage drop below 85% of nominal voltage

- 0, Normal
- Bit 3 LDO4\_UV\_STS: LDO4 under voltage flag.  
1, Output voltage drop below 85% of nominal voltage  
0, Normal
- Bit 2 LDO3\_UV\_STS: LDO3 under voltage flag.  
1, Output voltage drop below 85% of nominal voltage  
0, Normal
- Bit 1 LDO2\_UV\_STS: LDO2 under voltage flag.  
1, Output voltage drop below 85% of nominal voltage  
0, Normal
- Bit 0 LDO1\_UV\_STS: LDO1 under voltage flag.  
1, Output voltage drop below 85% of nominal voltage  
0, Normal

● **LDO\_UV\_ACT\_REG : LDO Under Voltage Action Register**

Address: 2AH				Type: RW				
Bit	Bit7	Bit6	Bit5	Bit4	Bit3	Bit2	Bit1	Bit0
SYMBOL	LDO8_U V_ACT	LDO7_U V_ACT	LDO6_U V_ACT	LDO5_U V_ACT	LDO4_U V_ACT	LDO3_U V_ACT	LDO2_U V_ACT	LDO1_U V_ACT
Default	1	1	1	1	1	1	1	1

**Description**

- Bit 7 LDO8\_UV\_ACT: LDO8 under voltage action  
1: restart converter  
0: No effect
- Bit 6 LDO7\_UV\_ACT: LDO7 under voltage action  
1: restart converter  
0: No effect
- Bit 5 LDO6\_UV\_ACT: LDO6 under voltage action  
1: restart converter  
0: No effect
- Bit 4 LDO5\_UV\_ACT: LDO5 under voltage action  
1: restart converter  
0: No effect
- Bit 3 LDO4\_UV\_ACT: LDO4 under voltage action  
1: restart converter  
0: No effect
- Bit 2 LDO3\_UV\_ACT: LDO3 under voltage action  
1: restart converter  
0: No effect
- Bit 1 LDO2\_UV\_ACT: LDO2 under voltage action  
1: restart converter  
0: No effect
- Bit 0 LDO1\_UV\_ACT: LDO1 under voltage action  
1: restart converter  
0: No effect

● **DCDC\_PG\_REG : DC-DC Converter Power Good Status Register**

Address: 2BH				Type: R				
Bit	Bit7	Bit6	Bit5	Bit4	Bit3	Bit2	Bit1	Bit0
SYMBOL	RESV	RESV	RESV	RESV	BUCK4_P G_STS	BUCK3_P G_STS	BUCK2_P G_STS	BUCK1_P G_STS
Default	0	0	0	0	0	0	0	0

**Description**

Bit 7-5 Reserved

Bit 4 Reserved

- Bit 3 BUCK4\_PG\_STS : BUCK4 power good flag.  
1: Power good, Vout>90% of setting voltage  
0: Power not good, Vout<90% of setting voltage
- Bit 2 BUCK3\_PG\_STS : BUCK3 power good flag.  
1: Power good, Vout>90% of setting voltage  
0: Power not good, Vout<90% of setting voltage
- Bit 1 BUCK2\_PG\_STS : BUCK2 power good flag.  
1: Power good, Vout>90% of setting voltage  
0: Power not good, Vout<90% of setting voltage
- Bit 0 BUCK1\_PG\_STS : BUCK1 power good flag.  
1: Power good, Vout>90% of setting voltage  
0: Power not good, Vout<90% of setting voltage

● **LDO\_PG\_REG : LDO Power Good Status Register**

Address: 2CH				Type: R				
Bit	Bit7	Bit6	Bit5	Bit4	Bit3	Bit2	Bit1	Bit0
SYMBOL	LDO8_PG _STS	LDO7_PG _STS	LDO6_PG _STS	LDO5_PG _STS	LDO4_PG _STS	LDO3_P G_STS	LDO2_P G_STS	LDO1_P G_STS
Default	0	0	0	0	0	0	0	0

**Description**

- Bit 7 LDO8\_PG\_STS : LDO8 power good flag.  
1: Power good, Vout>90% of setting voltage  
0: Power not good, Vout<90% of setting voltage
- Bit 6 LDO7\_PG\_STS : LDO7 power good flag.  
1: Power good, Vout>90% of setting voltage  
0: Power not good, Vout<90% of setting voltage
- Bit 5 LDO6\_PG\_STS : LDO6 power good flag.  
1: Power good, Vout>90% of setting voltage  
0: Power not good, Vout<90% of setting voltage
- Bit 4 LDO5\_PG\_STS : LDO5 power good flag.  
1: Power good, Vout>90% of setting voltage  
0: Power not good, Vout<90% of setting voltage

- Bit 3 LDO4\_PG\_STS : LDO4 power good flag.  
1: Power good, Vout>90% of setting voltage  
0: Power not good, Vout<90% of setting voltage
- Bit 2 LDO3\_PG\_STS : LDO3 power good flag.  
1: Power good, Vout>90% of setting voltage  
0: Power not good, Vout<90% of setting voltage
- Bit 1 LDO2\_PG\_STS : LDO2 power good flag.  
1: Power good, Vout>90% of setting voltage  
0: Power not good, Vout<90% of setting voltage
- Bit 0 LDO1\_PG\_STS : LDO1 power good flag.  
1: Power good, Vout>90% of setting voltage  
0: Power not good, Vout<90% of setting voltage

● **VOUT\_MON\_TDB\_REG : VOUT Debounce Monitor Register**

Address: 2DH				Type: RW				
Bit	Bit7	Bit6	Bit5	Bit4	Bit3	Bit2	Bit1	Bit0
SYMBOL	RESV	RESV	RESV	RESV	RESV	RESV	VOUT_MON_TDB	
Default	0	0	0	0	0	0	1	0

**Description**

- Bit 7-2 Reserved
- Bit 1-0 VOUT\_MON\_TDB: Vout monitor debouncing time(UV\_STS rising edge and PG\_STS rising edge debounce time)  
00: 62us  
01: 124us  
10: 186us(default)  
11: 248us

**5.2.4 Power Channel Configuration Registers**

● **BUCK1\_CONFIG\_REG : BUCK1 Configuration Register**

Address: 2EH				Type: RW				
Bit	Bit7	Bit6	Bit5	Bit4	Bit3	Bit2	Bit1	Bit0
SYMBOL	RESV	BUCK1_PHASE	RESV	BUCK1_RATE		BUCK1_ILMIN		
Default	0	0	0	0	0	0	0	1

**Description**

- Bit 7 Reserved
- Bit 6 BUCK1\_PHASE,  
0: Normal,  
1: Inverted
- Bit 5 Reserved

- Bit 4-3 BUCK1\_RATE: Voltage change rate after DVS  
 00: 2mv/us  
 01: 4mv/us  
 10: 6mv/us  
 11: 10mv/us
- Bit 2-0 BUCK1\_ILMIN: The minimum of inductor current  
 000: 50mA  
 001: 100mA(default);  
 010: 150mA  
 011: 200mA  
 100: 250mA  
 101: 300mA  
 110: 350mA  
 111: 400mA

● **BUCK1\_ON\_VSEL : BUCK1 Active Mode Register**

Address: 2FH				Type: RW				
Bit	Bit7	Bit6	Bit5	Bit4	Bit3	Bit2	Bit1	Bit0
SYMBOL	RESV	RESV	BUCK1_ON_VSEL					
Default	Boot							

**Description**

- Bit 7 Reserved
- Bit 6 Reserved
- Bit 5-0 BUCK1\_ON\_VSEL: BUCK1 active mode voltage select,  
 0.7125V~1.5V ,step=12.5mV  
 000 000: 0.7125V  
 000 001: 0.725V  
 .....  
 111 111: 1.5V  
 The default value is set by boot.

● **BUCK1\_SLP\_VSEL : BUCK1 Sleep Mode Register**

Address: 30H				Type: RW				
Bit	Bit7	Bit6	Bit5	Bit4	Bit3	Bit2	Bit1	Bit0
SYMBOL	RESV	RESV	BUCK1_SLP_VSEL					
Default	0	0	0	0	0	0	0	0

**Description**

- Bit 7 Reserved
- Bit 6 Reserved
- Bit 5-0 BUCK1\_SLP\_VSEL: BUCK1 sleep mode voltage select,  
 0.7125V~1.5V ,step=12.5mV  
 000 000: 0.7125V  
 000 001: 0.725V  
 .....

111 111: 1.5V

● **BUCK1\_DVS\_VSEL : BUCK1 DVS Mode Register**

Address: 31H				Type: RW				
Bit	Bit7	Bit6	Bit5	Bit4	Bit3	Bit2	Bit1	Bit0
SYMBOL	RESV	RESV	BUCK1_DVS_VSEL					
Default	0	0	0	0	0	0	0	0

**Description**

Bit 7-6 Reserved  
 Bit 5-0 BUCK1\_DVS\_VSEL: BUCK1 DVS voltage select,  
 0.7125V~1.5V ,step=12.5mV  
 000 000: 0.7125V  
 000 001: 0.725V  
 .....  
 111 111: 1. 5V

● **BUCK2\_CONFIG\_REG : BUCK2 Configuration Register**

Address: 32H				Type: RW				
Bit	Bit7	Bit6	Bit5	Bit4	Bit3	Bit2	Bit1	Bit0
SYMBOL	RESV	BUCK2_PHASE	RESV	BUCK2_RATE		BUCK2_ILMIN		
Default	0	0	0	0	0	0	0	1

**Description**

Bit 7 Reserved  
 Bit 6 BUCK2\_PHASE,  
 0: Normal,  
 1: Inverted  
 Bit 5 Reserved  
 Bit 4-3 BUCK2\_RATE: Voltage change rate after DVS  
 00: 2mv/us  
 01: 4mv/us  
 10: 6mv/us  
 11: 10mv/us  
 Bit 2-0 BUCK2\_ILMIN: The minimum of inductor current  
 000: 50mA  
 001: 100mA(default);  
 010: 150mA  
 011: 200mA  
 100: 250mA  
 101: 300mA  
 110: 350mA

111: 400mA

● **BUCK2\_ON\_VSEL : BUCK2 Active Mode Register**

Address: 33H				Type: RW				
Bit	Bit7	Bit6	Bit5	Bit4	Bit3	Bit2	Bit1	Bit0
SYMBOL	RESV	RESV	BUCK2_ON_VSEL					
Default	Boot							

**Description**

Bit 7 Reserved  
 Bit 6 Reserved  
 Bit 5-0 BUCK2\_ON\_VSEL: BUCK2 active mode voltage select,  
 0.7125V~1.5V ,step=12.5mV  
 000 000: 0.7125V  
 000 001: 0.725V  
 .....  
 111 111: 1.5V  
 The default value is set by boot.

● **BUCK2\_SLP\_VSEL : BUCK2 Sleep Mode Register**

Address: 34H				Type: RW				
Bit	Bit7	Bit6	Bit5	Bit4	Bit3	Bit2	Bit1	Bit0
SYMBOL	RESV	RESV	BUCK2_SLP_VSEL					
Default	0	0	0	0	0	0	0	0

**Description**

Bit 7 Reserved  
 Bit 6 Reserved  
 Bit 5-0 BUCK2\_SLP\_VSEL: BUCK1 sleep mode voltage select,  
 0.7125V~1.5V ,step=12.5mV  
 000 000: 0.7125V  
 000 001: 0.725V  
 .....  
 111 111: 1.5V

● **BUCK2\_DVS\_VSEL : BUCK2 DVS Mode Register**

Address: 35H				Type: RW				
Bit	Bit7	Bit6	Bit5	Bit4	Bit3	Bit2	Bit1	Bit0
SYMBOL	RESV	RESV	BUCK2_DVS_VSEL					
Default	0	0	0	0	0	0	0	0

**Description**

Bit 7-6 Reserved  
 Bit 5-0 BUCK2\_DVS\_VSEL: BUCK1 DVS voltage select,  
 0.7125V~1.5V ,step=12.5mV  
 000 000: 0.7125V  
 000 001: 0.725V  
 .....  
 111 111: 1.5V

● **BUCK3\_CONFIG\_REG : BUCK3 Configuration Register**

Address: 36H				Type: RW				
Bit	Bit7	Bit6	Bit5	Bit4	Bit3	Bit2	Bit1	Bit0
SYMBOL	RESV	BUCK3_PHASE	RESV	RESV	RESV	BUCK3_ILMIN		
Default	0	0	0	0	0	0	0	1

**Description**

Bit 7 Reserved  
 Bit 6 BUCK3\_PHASE,  
 0: Normal,  
 1: Inverted  
 Bit 5-3 Reserved  
 Bit 2-0 BUCK3\_ILMIN: The minimum of inductor current  
 000: 50mA  
 001: 100mA(default);  
 010: 150mA  
 011: 200mA  
 100: 250mA  
 101: 300mA  
 110: 350mA  
 111: 400mA

● **BUCK4\_CONFIG\_REG : BUCK4 Configuration Register**

Address: 37H				Type: RW				
Bit	Bit7	Bit6	Bit5	Bit4	Bit3	Bit2	Bit1	Bit0
SYMBOL	RESV	BUCK4_PHASE	RESV	RESV	RESV	BUCK4_ILMIN		
Default	0	0	0	0	0	0	0	0

**Description**

Bit 7 Reserved  
 Bit 6 BUCK4\_PHASE,  
 0: Normal,  
 1: Inverted  
 Bit 2-0 BUCK4\_ILMIN:The minimum of inductor current  
 000: 50mA  
 001: 100mA(default);



- 010: 150mA
- 011: 200mA
- 100: 250mA
- 101: 300mA
- 110: 350mA
- 111: 400mA

● **BUCK4\_ON\_VSEL : BUCK4 Active Mode Register**

Address: 38H				Type: RW				
Bit	Bit7	Bit6	Bit5	Bit4	Bit3	Bit2	Bit1	Bit0
SYMBOL	RESV	RESV	RESV	RESV	BUCK4_ON_VSEL			
Default	Boot							

**Description**

Bit 7 Reserved  
 Bit 6-4 Reserved  
 Bit 3-0 BUCK4\_ON\_VSEL: BUCK4 active mode voltage select,  
 1.8V~3.3V ,step=100mV  
 0000: 1.8V  
 0001: 1.9V  
 .....  
 1110: 3.2V  
 1111: 3.3V  
 the default value is set by boot.

● **BUCK4\_SLP\_VSEL : BUCK4 Sleep Mode Register**

Address: 39H				Type: RW				
Bit	Bit7	Bit6	Bit5	Bit4	Bit3	Bit2	Bit1	Bit0
SYMBOL	RESV	RESV	RESV	RESV	BUCK4_SLP_VSEL			
Default	0	0	0	0	0	0	0	0

**Description**

Bit 7 Reserved  
 Bit 6-4 Reserved  
 Bit 3-0 BUCK4\_SLP\_VSEL: BUCK4 sleep mode voltage select,  
 1.8V~3.3V ,step=100mV  
 0000: 1.8V  
 0001: 1.9V  
 .....  
 1110: 3.2V  
 1111: 3.3V

● **LDO1\_ON\_VSEL\_REG : LDO1 Active Mode Voltage Select**

Address: 3BH				Type: RW				
Bit	Bit7	Bit6	Bit5	Bit4	Bit3	Bit2	Bit1	Bit0
SYMBOL	RESV	RESV	RESV	LDO1_ON_VSEL				
Default	Boot							

**Description**

Bit 7-5 Reserved  
 Bit 4-0 LDO1\_ON\_VSEL: LDO1 active mode voltage select.  
 1.8V~3.4V, step=0.1V  
 00000: 1.8V  
 00001: 1.9V  
 ...  
 01110: 3.2V  
 01111: 3.3V  
 10000: 3.4V  
 the default value is set by boot.

● **LDO1\_SLP\_VSEL\_REG : LDO1 Sleep Mode Voltage Select**

Address: 3CH				Type: RW				
Bit	Bit7	Bit6	Bit5	Bit4	Bit3	Bit2	Bit1	Bit0
SYMBOL	RESV	RESV	RESV	LDO1_SLP_VSEL				
Default	0	0	0	0	0	0	0	0

**Description**

Bit 7-5 Reserved  
 Bit 4-0 LDO1\_SLP\_VSEL: LDO1 SLEEP mode voltage select.  
 1.8V~3.4V, step=0.1V  
 00000: 1.8V  
 00001: 1.9V  
 ...  
 01110: 3.2V  
 01111: 3.3V  
 10000: 3.4V

● **LDO2\_ON\_VSEL\_REG : LDO2 Active Mode Voltage Select**

Address: 3DH				Type: RW				
Bit	Bit7	Bit6	Bit5	Bit4	Bit3	Bit2	Bit1	Bit0
SYMBOL	RESV	RESV	RESV	LDO2_ON_VSEL				
Default	Boot							

**Description**

Bit 7-5 Reserved  
 Bit 4-0 LDO2\_ON\_VSEL: LDO2 active mode voltage select.  
 1.8V~3.4V, step=0.1V  
 00000: 1.8V

00001: 1.9V  
 ...  
 01110: 3.2V  
 01111: 3.3V  
 10000: 3.4V  
 the default value is set by boot.

● **LDO2\_SLP\_VSEL\_REG : LDO2 Sleep Mode Voltage Select**

Address: 3EH				Type: RW				
Bit	Bit7	Bit6	Bit5	Bit4	Bit3	Bit2	Bit1	Bit0
SYMBOL	RESV	RESV	RESV	LDO2_SLP_VSEL				
Default	0	0	0	0	0	0	0	0

**Description**

Bit 7-5 Reserved  
 Bit 4-0 LDO2\_SLP\_VSEL: LDO2 SLEEP mode voltage select.  
 1.8V~3.4V, step=0.1V  
 00000: 1.8V  
 00001: 1.9V  
 ...  
 01110: 3.2V  
 01111: 3.3V  
 10000: 3.4V

● **LDO3\_ON\_VSEL\_REG : LDO3 Active Mode Voltage Select**

Address: 3FH				Type: RW				
Bit	Bit7	Bit6	Bit5	Bit4	Bit3	Bit2	Bit1	Bit0
SYMBOL	RESV	RESV	RESV	RESV	LDO3_ON_VSEL			
Default	Boot							

**Description**

Bit 7-4 Reserved  
 Bit 3-0 LDO3\_ON\_VSEL: LDO3 active voltage select.  
 0.8V~2.5V, step=0.1V  
 0000: 0.8V  
 0001: 0.9V  
 ...  
 1100: 2.0V  
 1101: 2.2V  
 1111: 2.5V  
 the default value is set by boot.

● **LDO3\_SLP\_VSEL\_REG : LDO3 Sleep Mode Voltage Select**

Address: 40H				Type: RW				
Bit	Bit7	Bit6	Bit5	Bit4	Bit3	Bit2	Bit1	Bit0

SYMBOL	RESV	RESV	RESV	RESV	LDO3_SLP_VSEL			
Default	0	0	0	0	0	0	0	0

**Description**

Bit 7-4 Reserved  
 Bit 3-0 LDO3\_SLP\_VSEL: LDO3 SLEEP mode voltage select.  
 0.8V~2.5V, step=0.1V  
 0000: 0.8V  
 0001: 0.9V  
 ...  
 1100: 2.0V  
 1101: 2.2V  
 1111: 2.5V  
 the default value is set by boot.

● **LDO4\_ON\_VSEL\_REG : LDO4 Active Mode Voltage Select**

Address: 41H				Type: RW				
Bit	Bit7	Bit6	Bit5	Bit4	Bit3	Bit2	Bit1	Bit0
SYMBOL	RESV	RESV	RESV	LDO4_ON_VSEL				
Default	Boot							

**Description**

Bit 7-5 Reserved  
 Bit 4-0 LDO4\_ON\_VSEL: LDO4 active mode voltage select.  
 1.8V~3.4V, step=0.1V  
 00000: 1.8V  
 00001: 1.9V  
 ...  
 01110: 3.2V  
 01111: 3.3V  
 10000: 3.4V  
 the default value is set by boot.

● **LDO4\_SLP\_VSEL\_REG : LDO4 Sleep Mode Voltage Select**

Address: 42H				Type: RW				
Bit	Bit7	Bit6	Bit5	Bit4	Bit3	Bit2	Bit1	Bit0
SYMBOL	RESV	RESV	RESV	LDO4_SLP_VSEL				
Default	0	0	0	0	0	0	0	0

**Description**

Bit 7-5 Reserved  
 Bit 4-0 LDO2\_SLP\_VSEL: LDO2 SLEEP mode voltage select.  
 1.8V~3.4V, step=0.1V  
 00000: 1.8V

00001: 1.9V  
 ...  
 01110: 3.2V  
 01111: 3.3V  
 10000: 3.4V

● **LDO5\_ON\_VSEL\_REG : LDO5 Active Mode Voltage Select**

Address: 43H				Type: RW				
Bit	Bit7	Bit6	Bit5	Bit4	Bit3	Bit2	Bit1	Bit0
SYMBOL	RESV	RESV	RESV	LDO5_ON_VSEL				
Default	Boot							

**Description**

Bit 7-5 Reserved  
 Bit 4-0 LDO5\_ON\_VSEL: LDO5 active mode voltage select.  
 1.8V~3.4V, step=0.1V  
 00000: 1.8V  
 00001: 1.9V  
 ...  
 01110: 3.2V  
 01111: 3.3V  
 10000: 3.4V  
 the default value is set by boot.

● **LDO5\_SLP\_VSEL\_REG : LDO5 Sleep Mode Voltage Select**

Address: 44H				Type: RW				
Bit	Bit7	Bit6	Bit5	Bit4	Bit3	Bit2	Bit1	Bit0
SYMBOL	RESV	RESV	RESV	LDO5_SLP_VSEL				
Default	0	0	0	0	0	0	0	0

**Description**

Bit 7-5 Reserved  
 Bit 4-0 LDO5\_SLP\_VSEL: LDO5 SLEEP mode voltage select.  
 1.8V~3.4V, step=0.1V  
 00000: 1.8V  
 00001: 1.9V  
 ...  
 01110: 3.2V  
 01111: 3.3V  
 10000: 3.4V

● **LDO6\_ON\_VSEL\_REG : LDO6 Active Mode Voltage Select**

Address: 45H				Type: RW				
Bit	Bit7	Bit6	Bit5	Bit4	Bit3	Bit2	Bit1	Bit0

SYMBOL	RESV	RESV	RESV	LDO6_ON_VSEL
Default	Boot			

**Description**

Bit 7-5 Reserved  
 Bit 4-0 LDO6\_ON\_VSEL: LDO6 active mode voltage select.  
 0.8V~2.5V, step=0.1V  
 00000: 0.8V  
 00001: 0.9V  
 .....  
 10000: 2.4V  
 10001: 2.5V  
 the default value is set by boot.

● **LDO6\_SLP\_VSEL\_REG : LDO6 Sleep Mode Voltage Select**

Address: 46H				Type: RW				
Bit	Bit7	Bit6	Bit5	Bit4	Bit3	Bit2	Bit1	Bit0
SYMBOL	RESV	RESV	RESV	LDO6_SLP_VSEL				
Default	0	0	0	0	0	0	0	0

**Description**

Bit 7-5 Reserved  
 Bit 4-0 LDO6\_SLP\_VSEL: LDO6 SLEEP mode voltage select.  
 0.8V~2.5V, step=0.1V  
 00000: 0.8V  
 00001: 0.9V  
 .....  
 10000: 2.4V  
 10001: 2.5V

● **LDO7\_ON\_VSEL\_REG : LDO7 Active Mode Voltage Select**

Address: 47H				Type: RW				
Bit	Bit7	Bit6	Bit5	Bit4	Bit3	Bit2	Bit1	Bit0
SYMBOL	RESV	RESV	RESV	LDO7_ON_VSEL				
Default	Boot							

**Description**

Bit 7-5 Reserved  
 Bit 4-0 LDO7\_ON\_VSEL: LDO7 active mode voltage select.  
 0.8V~2.5V, step=0.1V  
 00000: 0.8V  
 00001: 0.9V  
 .....  
 10000: 2.4V  
 10001: 2.5V

the default value is set by boot.

● **LDO7\_SLP\_VSEL\_REG : LDO7 Sleep Mode Voltage Select**

Address: 48H				Type: RW				
Bit	Bit7	Bit6	Bit5	Bit4	Bit3	Bit2	Bit1	Bit0
SYMBOL	RESV	RESV	RESV	LDO7_SLP_VSEL				
Default	0	0	0	0	0	0	0	0

**Description**

Bit 7-5 Reserved  
 Bit 4-0 LDO7\_SLP\_VSEL: LDO7 SLEEP mode voltage select.  
 0.8V~2.5V, step=0.1V  
 00000: 0.8V  
 00001: 0.9V  
 .....  
 10000: 2.4V  
 10001: 2.5V

● **LDO8\_ON\_VSEL\_REG : LDO8 Active Mode Voltage Select**

Address: 49H				Type: RW				
Bit	Bit7	Bit6	Bit5	Bit4	Bit3	Bit2	Bit1	Bit0
SYMBOL	RESV	RESV	RESV	LDO8_ON_VSEL				
Default	Boot							

**Description**

Bit 7-5 Reserved  
 Bit 4-0 LDO8\_ON\_VSEL: LDO8 active mode voltage select.  
 1.8V~3.4V, step=0.1V  
 00000: 1.8V  
 00001: 1.9V  
 ...  
 01110: 3.2V  
 01111: 3.3V  
 10000: 3.4V  
 the default value is set by boot.

● **LDO8\_SLP\_VSEL\_REG : LDO8 Sleep Mode Voltage Select**

Address: 4AH				Type: RW				
Bit	Bit7	Bit6	Bit5	Bit4	Bit3	Bit2	Bit1	Bit0
SYMBOL	RESV	RESV	RESV	LDO8_SLP_VSEL				
Default	0	0	0	0	0	0	0	0

**Description**

Bit 7-5 Reserved  
 Bit 4-0 LDO8\_SLP\_VSEL: LDO8 SLEEP mode voltage select.  
 1.8V~3.4V, step=0.1V  
 00000: 1.8V  
 00001: 1.9V  
 ...  
 01110: 3.2V  
 01111: 3.3V  
 10000: 3.4V

● **DEVCTRL\_REG : Device Control Register**

Address: 4BH				Type: RW				
Bit	Bit7	Bit6	Bit5	Bit4	Bit3	Bit2	Bit1	Bit0
SYMBOL	RESV	RESV	PWRON_LP_OFF_TIME		RESV	RESV	DEV_SLP	DEV_OFF
Default	0	0	0	0	0	0	0	0

**Description**

Bit 7-6 Reserved  
 Bit 5-4 PWRON\_LP\_OFF\_TIME: PWRON long press turn off time:  
 00: 6s  
 01: 8s  
 10: 10s  
 11: 12s  
 Bit 3 Reserved  
 Bit 2 Reserved  
 Bit 1 DEV\_SLP: Write 1 allows SLEEP device state (if DEV\_OFF = 0).  
 Write '0' will start a SLEEP to ACTIVE device state transition (wake-up event) (if DEV\_OFF = 0). This bit is cleared in OFF state.  
 Bit 0 DEV\_OFF: Write 1 will start an ACTIVE to OFF or SLEEP to OFF device state transition (switch-off event). This bit is cleared in OFF state.

**5.2.5 Interrupt Registers**

● **INT\_STS\_REG1 : Interrupt Status Register #1**

Address: 4CH				Type: RW				
Bit	Bit7	Bit6	Bit5	Bit4	Bit3	Bit2	Bit1	Bit0
SYMBOL	RESV	RTC_PERIOD_INT (Write 1 Clr)	RTC_ALARM_INT (Write 1 Clr)	HOTDI_E_INT (Write 1 Clr)	PWRON_LP_INT (Write 1 Clr)	PWRO_N_INT (Write 1 Clr)	VB_LO_INT (Write 1 Clr)	VOUT_LO_INT (Write 1 Clr)
Default	0	0	0	0	0	0	0	0

**Description**

Bit 7 Reserved  
 Bit 6 RTC\_PERIOD\_INT: RTC period event interrupt.



- Bit 5 RTC\_ALARM\_INT: RTC alarm event interrupt.
- Bit 4 HOTDIE\_INT: Hot die event interrupt status.
- Bit 3 PWRON\_LP\_INT: PWRON PIN long press event interrupt status.
- Bit 2 PWRON\_INT: PWRON event interrupt status.
- Bit 1 VB\_LO\_INT: Battery under voltage alarm event interrupt status.
- Bit 0 VOUT\_LO\_INT: VOUT under voltage alarm event interrupt status
- Note: 1: Interrupt asserted, write "1" to clear  
0: No interrupt

● **INT\_MSK\_REG1 : Interrupt Mask Register #1**

Address: 4DH				Type: RW				
Bit	Bit7	Bit6	Bit5	Bit4	Bit3	Bit2	Bit1	Bit0
SYMBOL	RESV	RTC_PE RIOD_IM	RTC_AL ARM_IM	HOTDIE_ IM	PWRON _LP_IM	PWRON _IM	VB_LO_I M	VOUT_ LO_IM
Default	0	0	0	0	0	0	0	0

**Description**

- Bit 7 Reserved
- Bit 6 RTC\_PERIOD\_INT: RTC period event interrupt mask.
- Bit 5 RTC\_ALARM\_INT: RTC alarm event interrupt mask.
- Bit 4 HOTDIE\_INT: Hot die event interrupt status mask.
- Bit 3 PWRON\_LP\_INT: PWRON PIN long press event interrupt status mask.
- Bit 2 PWRON\_INT: PWRON event interrupt status mask.
- Bit 1 VB\_LO\_INT: Battery under voltage alarm event interrupt status mask.
- Bit 0 VOUT\_LO\_IM: Vout under voltage alarm event interrupt status mask
- Note: 1: Mask the specified interrupt  
0: Do not mask the specified interrupt

● **INT\_STS\_REG2 : Interrupt Status Register #2**

Address: 4EH				Type: RW				
Bit	Bit7	Bit6	Bit5	Bit4	Bit3	Bit2	Bit1	Bit0
SYMBOL	RESV	RESV	RESV	RESV	RESV	RESV	PLUG_OU T_INT (Write 1 Clr)	PLUG_I N_INT (Write 1 Clr)
Default	0	0	0	0	0	0	0	0

**Description**

- Bit 7-2 Reserved
- Bit 1 PLUG\_OUT\_INT: charger plug out event interrupt(PLUG\_IN\_STS falling edge interrupt)
- Bit 0 PLUG\_IN\_INT: charger plug in event interrupt(PLUG\_IN\_STS rising edge interrupt)
- Note: Write "1" to clear.

● **INT\_STS\_MSK\_REG2 : Interrupt Status Register #2**

Address: 4FH				Type: RW				
--------------	--	--	--	----------	--	--	--	--

Bit	Bit7	Bit6	Bit5	Bit4	Bit3	Bit2	Bit1	Bit0
SYMBOL	RESV	RESV	RESV	RESV	RESV	RESV	PLUG_OUT_INT_IM	PLUG_IN_INT_IM
Default	0	0	0	0	0	0	0	0

**Description**

- Bit 7-2 Reserved
- Bit 1 PLUG\_OUT\_INT\_IM: Charger plug out event interrupt mask.  
1: Mask the interrupt  
0: Do not mask the interrupt
- Bit 0 PLUG\_IN\_INT\_IM: Charger plug in event interrupt mask  
1: Mask the interrupt  
0: Do not mask the interrupt

● **IO\_POL\_REG : IO Polarity Register**

Address: 50H				Type: RW				
Bit	Bit7	Bit6	Bit5	Bit4	Bit3	Bit2	Bit1	Bit0
SYMBOL	RESV	RESV	RESV	RESV	RESV	DVS2_POL	DVS1_POL	INT_POL
Default	0	0	0	0	0	1	1	0

**Description**

- Bit 7-3 Reserved
- Bit 2 DVS2\_POL: DVS2 pin polarity  
0: active low  
1: active high
- Bit 1 DVS1\_POL: DVS1 pin polarity  
0: active low  
1: active high
- Bit 0 INT\_POL: INT pin polarity  
0: active low  
1: active high

● **DCDC\_ILMAX\_REG : DCDC max inductor current Register**

Address: 90H				Type: RW				
Bit	Bit7	Bit6	Bit5	Bit4	Bit3	Bit2	Bit1	Bit0
SYMBOL	BUCK4_ILMAX		BUCK3_ILMAX		BUCK2_ILMAX		BUCK1_ILMAX	
Default	0	1	0	1	0	1	0	1

**Description**

- Bit 7-6 BUCK4\_ILMAX: BUCK4 max inductor current  
00:2A 01:2.5A 10:3A 11:3.5A
- Bit 5-4 BUCK3\_ILMAX: BUCK4 max inductor current  
00:2A 01:2.5A 10:3A 11:3.5A

Bit 3-2 BUCK2\_ILMAX: BUCK4 max inductor current  
00:4.5A    01: 5A    10:5.5A    11:6A

Bit 1-0 BUCK1\_ILMAX: BUCK4 max inductor current  
00:4.5A    01: 5A    10:5.5A    11:6A

## Chapter 6 Thermal Management

### 6.1 Overview

For reliability and operability concerns, the absolute maximum junction temperature of RK808 has to be below 125°C.

Depending on the thermal mechanical design (Smartphone, Tablet, Personal Navigation Device, etc), the system thermal management software and worst case thermal applications, the junction temperature might be exposed to higher values than those specified above.

Therefore, it is recommended to perform thermal simulations at device level (Smartphone, Tablet, Personal Navigation Device, etc) with the measured power of the worst case UC of the device.

### 6.2 Package Thermal Characteristics

Table 6-1 provides the thermal resistance characteristics for the package used on this device.

Table 6-1 Thermal Resistance Characteristics

<b>PACKAGE (QFN68)</b>	<b>POWER(W)</b>	$\theta_{JA}(\text{°C/W})$	$\theta_{JB}(\text{°C/W})$	$\theta_{JC}(\text{°C/W})$
RK808	2	21.99	N/A	6.58

*Note: The testing PCB is based on 2 layers, 114mm x 76 mm, 1.6 mm Thickness, Ambient temperature is 85° C.*