

Features

- Unidirectional ESD protection of one line
- Low diode capacitance: $C_d = 25 \text{ pF}$
- Low clamping voltage: $V_{CL} = 12 \text{ V}$
- Very low leakage current: $I_{RM} = 10 \text{ nA}$
- ESD protection up to 26 kV
- IEC 61000-4-2; level 4 (ESD)
- AEC-Q101 qualified

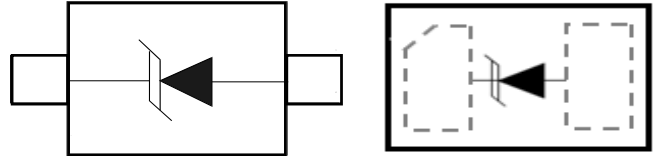

Applications

- Computers and peripherals
- Audio and video equipment
- Cellular handsets and accessories
- Communication systems
- Subscriber Identity Module (SIM) card protection
- Portable electronics
- FireWire
- High-speed data lines

Mechanical Characteristics

- SOD-882 package
- Molding compound flammability rating: UL94 V-0
- Marking: Marking Code
- Packaging: Tape and Reel per EIA4 81
- RoHS/WEEE Compliant

Quick reference data

$T_{amb} = 25 \text{ °C}$ unless otherwise specified.

Symbol	Parameter	Conditions	Min	Typ	Max	Unit
V_{RWM}	reverse standoff voltage		-	-	5.0	V
C_d	diode capacitance	$f = 1 \text{ MHz}; V_R = 0 \text{ V}$	-	25	30	pF

Limiting values

In accordance with the Absolute Maximum Rating System (IEC 60134).

Symbol	Parameter	Conditions		Min	Max	Unit
P _{PP}	peak pulse power	t _p = 8/20 μs	[1][2]	-	42	W
I _{PP}	peak pulse current	t _p = 8/20 μs	[1][2]	-	3.5	A
T _j	junction temperature			-	150	°C
T _{amb}	ambient temperature			-55	+150	°C
T _{stg}	storage temperature			-65	+150	°C

[1] Non-repetitive current pulse 8/20 μs exponential decay waveform according to IEC 61000-4-5.

[2] Measured from pin 1 to pin 2.

ESD maximum ratings

T_{amb} = 25 °C unless otherwise specified.

Symbol	Parameter	Conditions		Min	Max	Unit
V _{ESD}	electrostatic discharge voltage	IEC 61000-4-2 (contact discharge)	[1]	-	26	kV
		machine model		-	400	V
		MIL-STD-883 (human body model)		-	10	kV

[1] Device stressed with ten non-repetitive ESD pulses.

ESD standards compliance

Standard	Conditions
IEC 61000-4-2; level 4 (ESD)	> 15 kV (air); > 8 kV (contact)
MIL-STD-883; class 3 (human body model)	> 4 kV

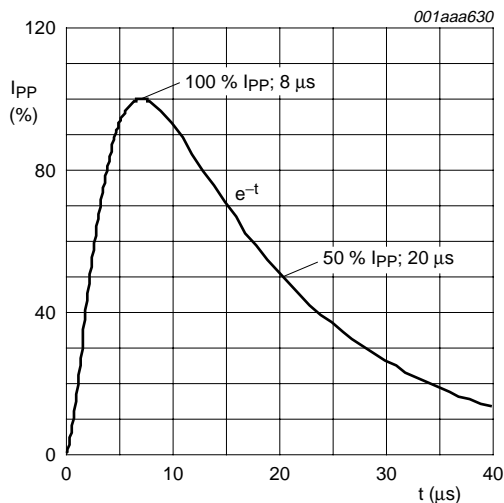

Fig 1. 8/20 μs pulse waveform according to IEC 61000-4-5

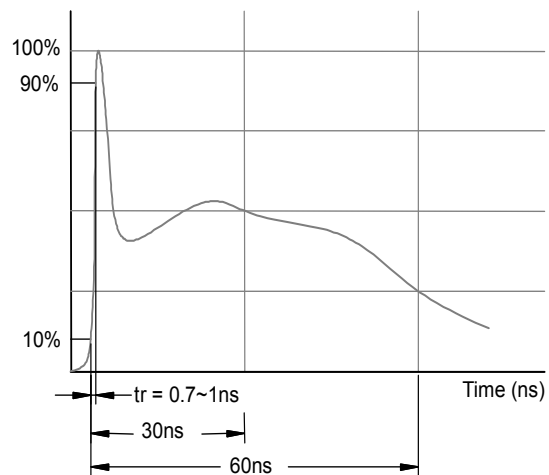

Fig 2. ESD pulse waveform according to IEC 61000-4-2

Characteristics

T_{amb} = 25 °C unless otherwise specified.

Symbol	Parameter	Conditions	Min	Typ	Max	Unit
V _{RWM}	reverse standoff voltage		-	-	5.0	V
I _{RM}	reverse leakage current	V _{RWM} = 5.0 V	-	10	100	nA
V _{BR}	breakdown voltage	I _R = 5 mA	6.4	6.8	7.2	V
C _d	diode capacitance	f = 1 MHz; V _R = 0 V	-	25	30	pF
V _{CL}	clamping voltage	[1][2]				
		I _{PP} = 1 A	-	-	9	V
		I _{PP} = 3.5 A	-	-	12	V
r _{dif}	differential resistance	I _R = 5 mA	-	-	30	Ω
V _F	forward voltage	I _F = 200 mA	-	-	1.2	V

[1] Non-repetitive current pulse 8/20 μs exponential decay waveform according to IEC 61000-4-5.

[2] Measured from pin 1 to pin 2.

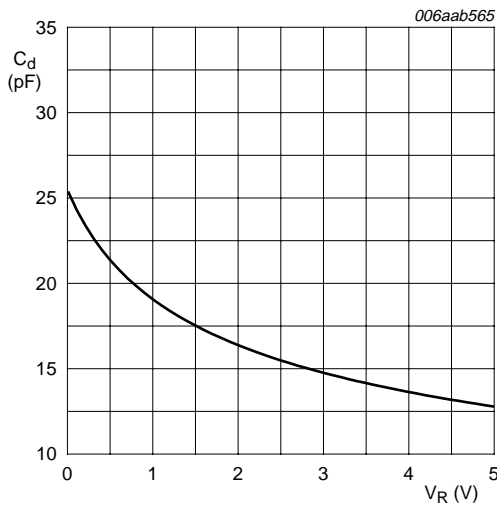

f = 1 MHz; T_{amb} = 25 °C

Fig 3. Diode capacitance as a function of reverse voltage; typical values

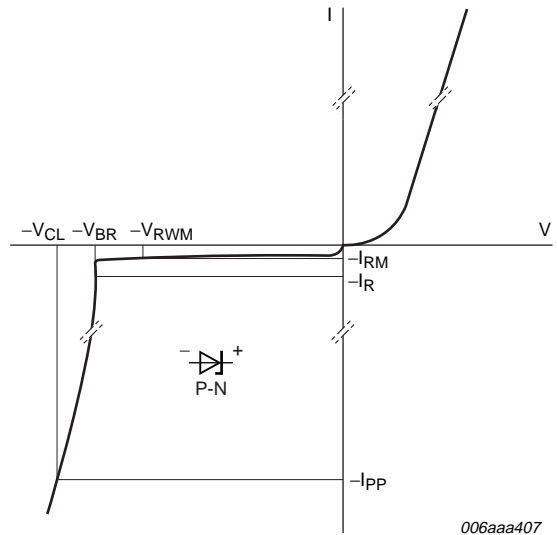
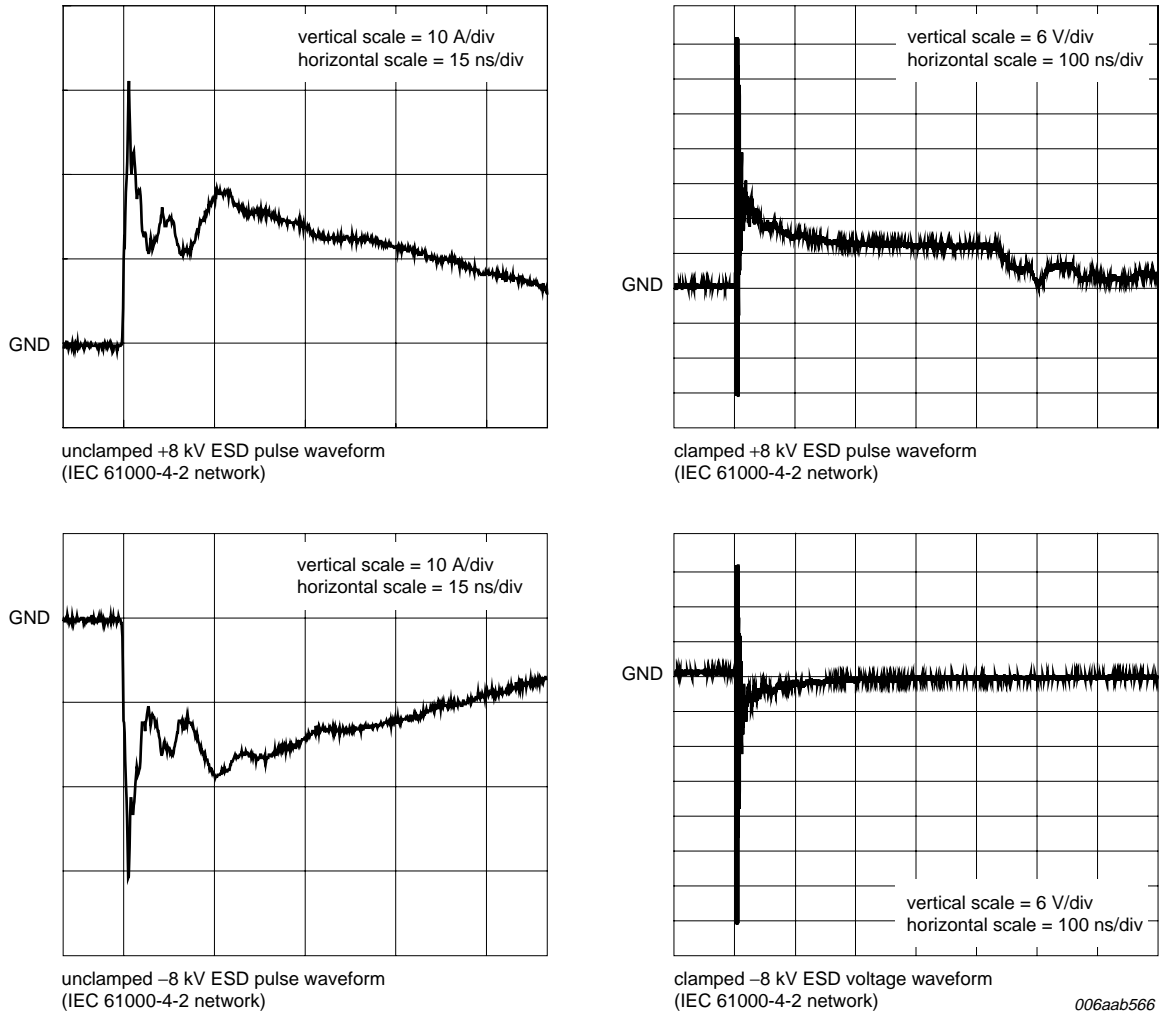

Fig 4. V-I characteristics for a unidirectional ESD protection diode



006aab566

Fig 5. ESD clamping test setup and waveforms

SOD-323/SOD-523/SOD-882 PACKAGE OUTLINE DIMENSIONS

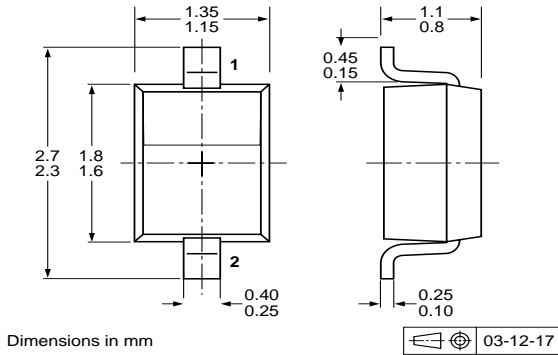

PESD5V0L1UA (SOD323)

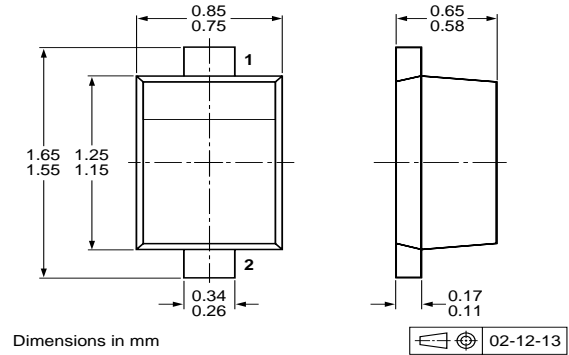

PESD5V0L1UB (SOD523)

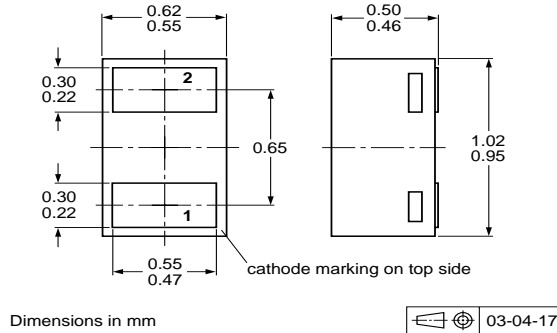

PESD5V0L1UL (SOD882)

Marking

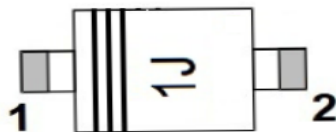

Ordering information

Order code	Marking code	Package	Baseqty	Deliverymode
UMW PESD5V0L1UA	1J	SOD-323	3000	Tape and reel
UMW PESD5V0L1UB	Z8	SOD-523	3000	Tape and reel
UMW PESD5V0L1UL	XY	SOD-882	10000	Tape and reel