

DIMENSIONS

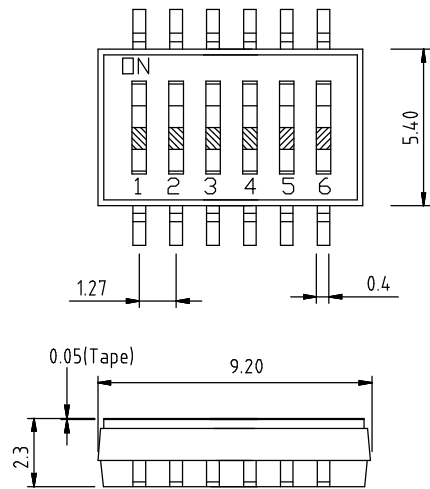

SCHEMATIC

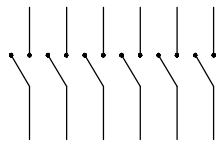

P.C.B LAYOUT

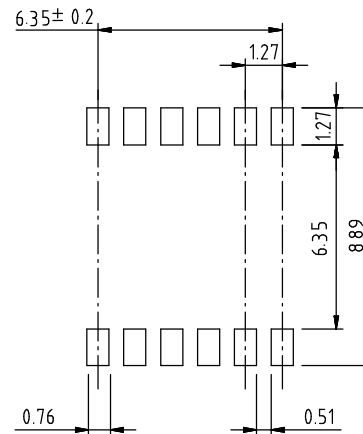

Rating (Resistive load):25mA 24VDC
Contact Resistance:100mΩ Max
Insulation Resistance:100MΩ Min
Dielectric Strength:500VAC 1 minute
Electrical life:1,000 cycles
Mechanical life:2,000 cycles
Operating Temperature:-30°C~85°C

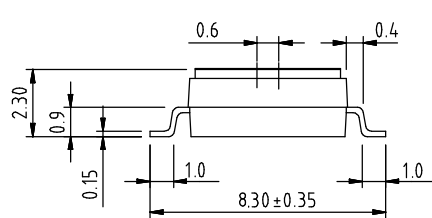

Poles(N) A Dimension(mm)

01	2.97	
02	4.12	
03	5.41	
04	6.66	
05	7.93	
06	9.20	✓
08	11.74	
10	14.28	
TOLERANCE:±0.1mm		

STRUCTURE

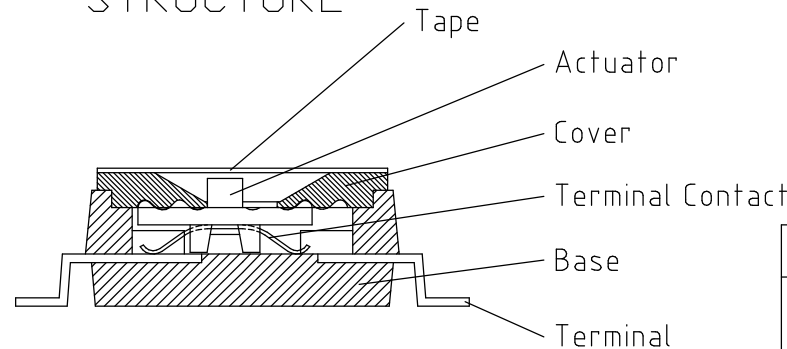

MATERIAL

Part Name	Material	Finished
Base	PPS UL94 V0	Black
Cover	PPS UL94 V0	Black
Actuator	Nylon UL94 V0	White
Movable	Beryllium	1μ " Gold
Terminal Contact	Brass	3μ " Gold
Terminal	Brass	1μ " Gold
Tape	Polyimide	Amber

Tolerance
0.1 - 100 : ±0.1
100 - 500 : ±0.2
500 - 1000 : ±0.3
1000 - 2000 : ±0.4



版本 VER		变更说明 CHANGE DESCRIPTION		日期 DATE	ECN NO.	版本 VERSION	A0	比例尺 SCALE	1:1	日期 DATE	2024.01.10	品名 TITLE	DSP-DSHP06TSGET	图号 DRAWING NO	XXXXXXX
						核准 APPROVED BY		核对 CHECKED BY		绘图 DRAWN BY	赵华玲				