

MSKSEMI 美森科

SEMICONDUCTOR



ESD



TVS



TSS



MOV



GDT



PLED

BA6208(MS)

产品规格手册

概述

BA6208(MS)是为5V和12V供电电压下工作的系统而设计的单通道低导通电阻直流电机驱动集成电路。集成了电机正转/反转/停止/刹车四个功能。

BA6208(MS)集成了温度保护功能，当芯片温度超过内部温度保护电路设置得最高温度点后，内部电路关断内置的功率开关管，切断负载电流，避免温度过高造成塑料封装冒烟、起火等安全隐患。



特性

- 工作电压 4.0-15.0V
- 持续电流 0.2A，峰值电流 0.3A
- 兼容 1.8V/3.3V/5.0V I/O
- 低导通电阻
- 低待机电流
- 低工作电流
- 集成过温保护功能

典型应用

- IR-CUT 驱动

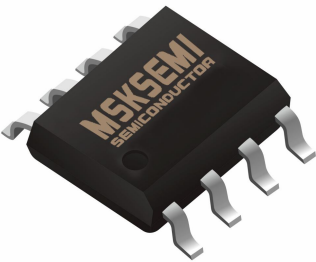
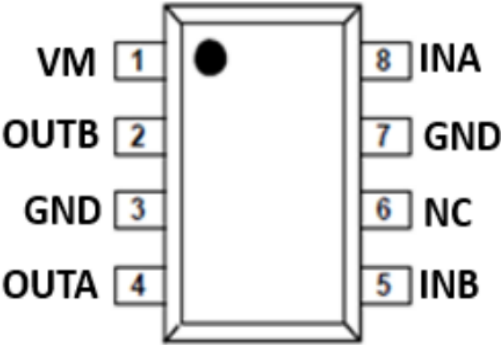
封装形式和管脚功能定义

封装图	脚位信息	管体标记
		
S0IC-8		

脚位定义

NO.	NAME	TYPE	DESCRIPTION
1	VM	P	电源输入脚，连接10uF或更大电容在VM和GND之间
2	OUTB	O	输出OUTB
3	GND	P	地
4	OUTA	O	输出OUTA
5	INB	I	逻辑输入INB
6	NC	I	悬空脚
7	GND	P	地，和3脚短接
8	INA	I	逻辑输入INA

简单应用电路

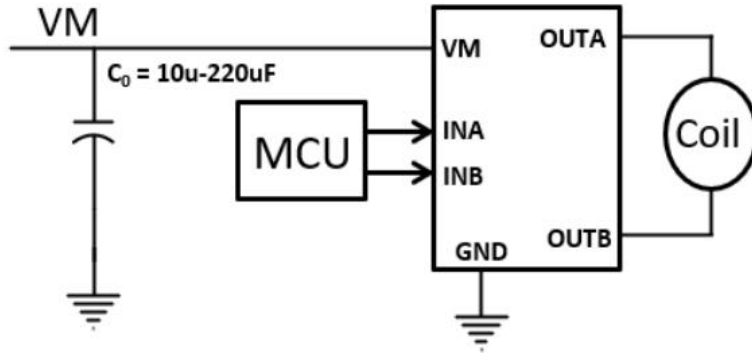

绝对最大额定值

参数		最小	最大	单位
电源电压	VM	-0.3	18.0	V
输入电压	INA,INB	-0.3	7.0	
静电保护 (人体模型)	VM, INA,INB,OUTA,OUTB	2		kV
工作温度	T _J	-40	150	°C
存储温度	T _{stg}	-65	150	
热阻	θ _{JA}		160	°C/W

推荐工作范围

参数		最小	最大	单位
电源电压	VM	4.0	15.0	V
输入电压	INA,INB	0	5.0	
输出电流	I _{OUTA} , I _{OUTB}	0	0.2	A

电气特性 (VM=12.0V, Ta=25 °C, R_{LOAD}=20)

参数		测试条件	最小值	典型值	最大值	单位
导通阻抗						
FET 导通电阻	R _{DSON}	I _{OUT} =100mA	6.0			Ω
INA/INB						
高电平输入电压	V _{INH}		1.5		5.0	V
低电平输入电压	V _{INL}		0		0.8	V
下拉电阻	R _{PD}			50	100	kΩ
工作电流						
电路关断电流	I _{VM_OFF}	INA=INB=0		1.0	10	uA
电路工作电流	I _{VM_ON}			180	400	uA
过温保护						
过温保护点	T _{OTSD}			160		°C
过温保护迟滞点	T _{HYS}			40		°C
VM 上升欠压保护	V _{UVLO_R}	VM 上升	3.60		4.00	V
VM 下降欠压保护	V _{UVLO_F}	VM 下降	3.35		3.75	V

功能框图

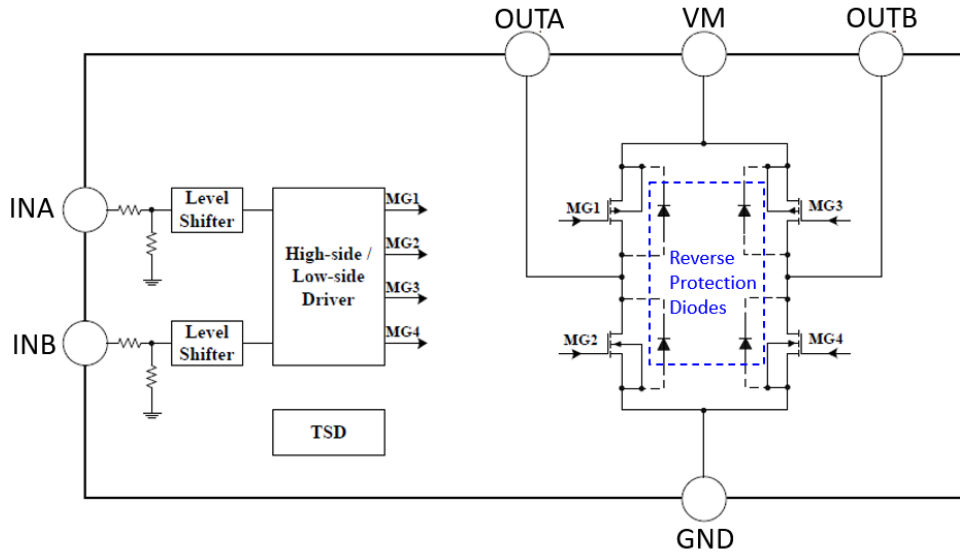

输入-输出逻辑表

IN1	IN2	OUT1	OUT2	工作状态	工作电流
L	L	Hi-Z	Hi-Z	待命状态	I_{VM_OFF}
H	L	H	L	前进	I_{VM_ON}
L	H	L	H	后退	I_{VM_ON}
H	H	L	L	刹车	I_{VM_ON}

输入-输出波形

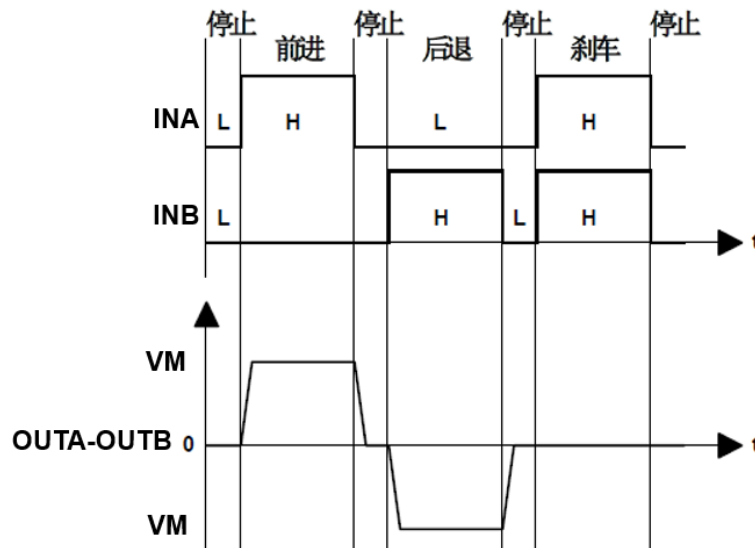

封装外形尺寸图
SOP8

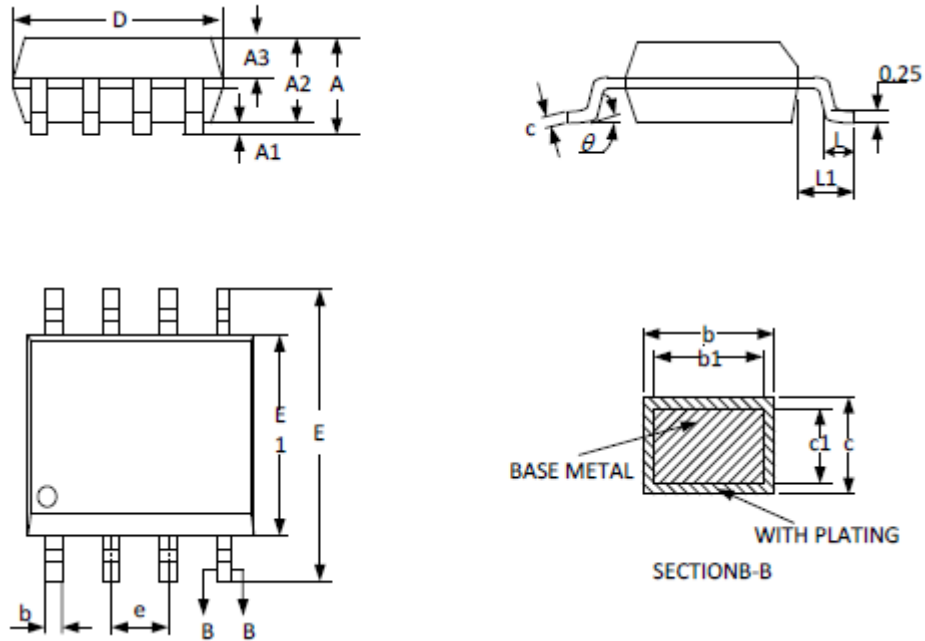

SYMBOL	MILLIMETER		
	MIN	NOM	MAX
A	--	--	1.77
A1	0.08	0.18	0.28
A2	1.20	1.40	1.60
A3	0.55	0.65	0.75
b	0.39	--	0.48
b1	0.38	0.41	0.43
c	0.21	--	0.26
c1	0.19	0.20	0.21
D	4.70	4.90	5.10
E	5.80	6.00	6.20
E1	3.70	3.90	4.10
e	1.27BSC		
L	0.50	0.65	0.80
L1	1.05BSC		
θ	0	--	8°

订购信息

P/N	PKG	QTY
BA6208(MS)	SOIC-8	4000

Attention

■ Any and all MSKSEMI Semiconductor products described or contained herein do not have specifications that can handle applications that require extremely high levels of reliability, such as life-support systems, aircraft's control systems, or other applications whose failure can be reasonably expected to result in serious physical and/or material damage. Consult with your MSKSEMI Semiconductor representative nearest you before using any MSKSEMI Semiconductor products described or contained herein in such applications.

■ MSKSEMI Semiconductor assumes no responsibility for equipment failures that result from using products at values that exceed, even momentarily, rated values (such as maximum ratings, operating condition ranges, or other parameters) listed in products specifications of any and all MSKSEMI Semiconductor products described or contained herein.

■ Specifications of any and all MSKSEMI Semiconductor products described or contained herein stipulate the performance, characteristics, and functions of the described products in the independent state, and are not guarantees of the performance, characteristics, and functions of the described products as mounted in the customer's products or equipment. To verify symptoms and states that cannot be evaluated in an independent device, the customer should always evaluate and test devices mounted in the customer's products or equipment.

■ MSKSEMI Semiconductor strives to supply high-quality high-reliability products. However, any and all semiconductor products fail with some probability. It is possible that these probabilistic failures could give rise to accidents or events that could endanger human lives, that could give rise to smoke or fire, or that could cause damage to other property. When designing equipment, adopt safety measures so that these kinds of accidents or events cannot occur. Such measures include but are not limited to protective circuits and error prevention circuits for safe design, redundant design, and structural design.

■ In the event that any or all MSKSEMI Semiconductor products (including technical data, services) described or contained herein are controlled under any of applicable local export control laws and regulations, such products must not be exported without obtaining the export license from the authorities concerned in accordance with the above law.

■ No part of this publication may be reproduced or transmitted in any form or by any means, electronic or mechanical, including photocopying and recording, or any information storage or retrieval system, or otherwise, without the prior written permission of MSKSEMI Semiconductor.

■ Information (including circuit diagrams and circuit parameters) herein is for example only ; it is not guaranteed for volume production. MSKSEMI Semiconductor believes information herein is accurate and reliable, but no guarantees are made or implied regarding its use or any infringement of intellectual property rights or other rights of third parties.

■ Any and all information described or contained herein are subject to change without notice due to product/technology improvement, etc. When designing equipment, refer to the "Delivery Specification" for the MSKSEMI Semiconductor product that you intend to use.