



MPQ8113/MPQ8113A

60V, High-Side Current-Sense Amplifier, AEC-Q100 Qualified

DESCRIPTION

The MPQ8113 and MPQ8113A are low-cost, unipolar, high-side current-sense amplifiers. The devices operate from a 2.7V to 60V supply and typically consume a 300 μ A current. They are ideal for today's automotive systems, industrial supplies, and systems where battery/DC current monitoring is critical.

High-side current monitoring is especially useful in battery-powered systems, since it does not interfere with the ground path of the battery charger. The common mode input voltage ranges between 0V and 60V, with a high 700kHz bandwidth. That makes these devices well-suited for inside control and short-circuit protection loops.

The MPQ8113 directly converts a differential input voltage to a voltage output with built-in internal common input resistors and a load resistor. The MPQ8113 has a 50V/V gain.

The MPQ8113A converts the differential input voltage to a current output. This current is converted back to a voltage with an external load resistor. The MPQ8113A has an adjustable gain based on the external common input resistors and load resistor.

Both the MPQ8113 and MPQ8113A are available in TSOT23-6L packages.

MPQ8113 FAMILY VERSIONS

Part Number	Output Gain
MPQ8113	50V/V
MPQ8113A	Adjustable

FEATURES

- Low-Cost, Compact Current-Sense Solution
- 700kHz Bandwidth
- 300 μ A Typical Supply Current
- 2.7V to 60V Operating Supply Voltage Range
- 0V to 60V Common Mode Input Voltage Range
- 0.2 μ A Typical Shutdown Current
- 300 μ V Input Offset Voltage
- Available with Fixed 50V/V Gain (MPQ8113), or Adjustable Gain (MPQ8113A)
- Adjustable Maximum Output Voltage
- \pm 1% Current-Sense Gain Accuracy
- High-Current Sensing Capabilities
- Available in a TSOT23-6L Package
- Available in AEC-Q100 Grade 1

APPLICATIONS

- Advanced Driver-Assistance Systems (ADAS)
- Sensor Fusion Systems
- Electric Power Steering (EPS) Systems
- Electronic Stability Control (ESC) Systems
- Brake Systems
- Battery-Operated Systems
- Energy Management Systems

All MPS parts are lead-free, halogen-free, and adhere to the RoHS directive. For MPS green status, please visit the MPS website under Quality Assurance. "MPS", the MPS logo, and "Simple, Easy Solutions" are trademarks of Monolithic Power Systems, Inc. or its subsidiaries.

TYPICAL APPLICATIONS

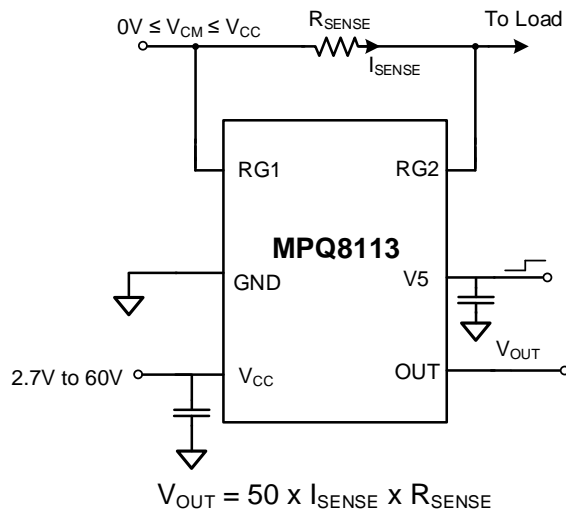

Figure 1: MPQ8113 (Voltage Output)

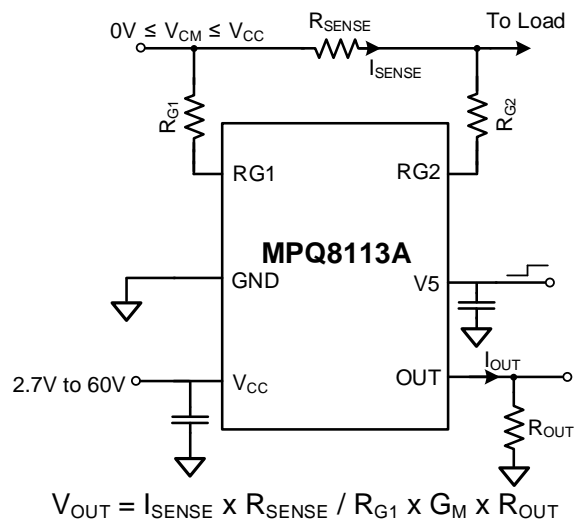

Figure 2: MPQ8113A (Current Output)

ORDERING INFORMATION

Part Number*	Package	Top/Bottom Markings	MSL Rating**
MPQ8113GJ-AEC1	TSOT23-6L	See Below	1
MPQ8113AGJ-AEC1	TSOT23-6L	See Below	

* For Tape & Reel, add suffix -Z (e.g. MPQ8113GJ-AEC1-Z).

** Moisture Sensitivity Level Rating

TOP MARKING

Part Number	Top Marking	Bottom Marking	Definitions
MPQ8113GJ-AEC1	BQJY	LLLL	BQJ: Product code Y: Year code LLLL: Lot number
MPQ8113AGJ-AEC1	BQHY	LLLL	BQH: Product code Y: Year code LLLL: Lot number

PACKAGE REFERENCE

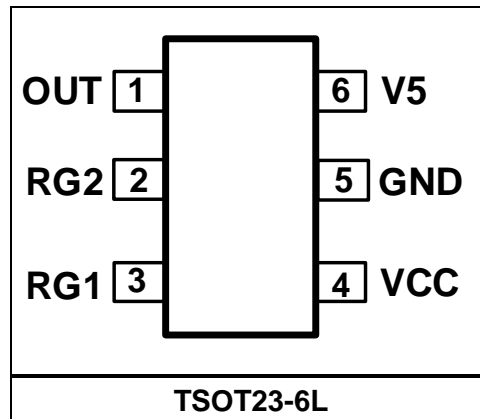

PIN FUNCTIONS

Pin #	Name	Description
1	OUT	Output. For the MPQ8113A, connect an external resistor between OUT and ground to set the gain. For the MPQ8113, there is an internal resistor (10kΩ) between OUT and ground. The MPQ8113 does not require an external resistor, so the OUT pin can be left floating.
2	RG2	Negative gain resistor. For the MPQ8113, connect RG2 directly to the load side of the current-sense resistor, and as close as possible to the resistor. For the MPQ8113A, connect RG2 to the load side of the current-sense resistor through a gain resistor (R _{G2}). R _{G2} should be below 4kΩ to obtain high current-sense accuracy. It is recommended for R _{G2} and R _{G1} to be 1kΩ.
3	RG1	Positive gain resistor. The voltage on the RG1 pin must not exceed the voltage on the VCC pin. For the MPQ8113, connect RG1 directly to the power side of the current-sense resistor, and as close as possible to the resistor. For the MPQ8113A, connect RG1 to the power side of the current-sense resistor through a gain resistor (R _{G1}). R _{G1} should be below 4kΩ to obtain high current-sense accuracy. It is recommended for R _{G2} and R _{G1} to be 1kΩ.
4	VCC	Power input. Supply for the internal input stage amplifier. Place a bypass capacitor between VCC and GND, and as close as possible to the VCC pin. A 0.1μF to 1μF low-ESR ceramic capacitor is recommended.
5	GND	Ground.
6	V5	Power supply for internal control and output block. Pull V5 above its 2V upper threshold to enable the part. Pull V5 below its 1.9V lower threshold to disable the part. V5 is also used to limit the maximum output voltage so that it does not exceed V5. The power source connected to V5 must be able to output a current above 5mA. Place a bypass capacitor between V5 and GND. A 10nF to 100nF low-ESR ceramic capacitor is recommended.

ABSOLUTE MAXIMUM RATINGS ⁽¹⁾

VCC to GND	-0.3V to +62V
RG1, RG2 to GND	-0.3V to V _{CC}
VCC to RG1, RG2	-0.3V to +62V
OUT to GND	-0.3V to V5
Differential input voltage (V _{RG1} - V _{RG2})	...±400mV
V5 to GND	-0.3V to +6V
Max junction temperature	150°C
Storage temperature	-65°C to +150°C
Continuous power dissipation (T _A = 25°C) ⁽²⁾	
TSOT23-6L	0.57W

ESD Ratings ⁽³⁾

Human body model (HBM)	±2kV
Charged device model (CDM)	±750V

Recommended Operating Conditions

VCC to GND	2.7V to 60V
RG1, RG2 to GND	0V to V _{CC}
VCC to RG1, RG2	0V to 60V
V5 to GND	2.7V to 5.5V
OUT to GND	0V to V5 - 1V
Operating junction temp (T _J)
	-40°C to +125°C ⁽⁴⁾

Thermal Resistance ⁽⁵⁾ θ_{JA} θ_{JC}

TSOT23-6L	220	110	°C/W
-----------	-----	-----	------

Notes:

- Exceeding these ratings may damage the device.
- The maximum allowable power dissipation is a function of the maximum junction temperature, T_J (MAX), the junction-to-ambient thermal resistance, θ_{JA}, and the ambient temperature, T_A. The maximum allowable continuous power dissipation at any ambient temperature is calculated by P_D (MAX) = (T_J (MAX) - T_A) / θ_{JA}. Exceeding the maximum allowable power dissipation can cause excessive die temperature, and the regulator may go into thermal shutdown. Internal thermal shutdown circuitry protects the device from permanent damage.
- These devices are ESD-sensitive. It is recommended to handle them with precaution.
- It is possible to operate the devices at junction temperatures above 125°C. Contact an MPS FAE for details.
- Measured on JESD51-7, 4-layer PCB. The values given in this table are only valid for comparison with other packages and cannot be used for design purposes. These values were calculated in accordance with JESD51-7, and simulated on a specified JEDEC board. They do not represent the performance obtained in an actual application.

ELECTRICAL CHARACTERISTICS

$V_{CC} = 12V$, $V_{RG1} = 12V$, $T_A = -40^{\circ}C$ to $+125^{\circ}C$, typical values at $T_J = 25^{\circ}C$. For the MPQ8113, $R_{G1} = R_{G2} = 0\Omega$, and R_{OUT} is not used. For the MPQ8113A, $R_{G1} = R_{G2} = 1k\Omega$, and $R_{OUT} = 10k\Omega$, unless otherwise noted.

Parameter	Symbol	Conditions	Min	Typ	Max	Units
Supply voltage	V_{CC}		2.7		60	V
Common mode input voltage	V_{CM}		0		V_{CC}	V
V5 supply voltage	V_5		2.7		5.5	V
Supply current	$I_{CC} + I_{V5}$	$V_{SENSE} = 0$, $V_{CC} = 60V$, $V_5 = 5V$		300	360	μA
Common mode input rejection ⁽⁶⁾	CMR	$V_{SENSE} = 80mV$, $V_{CC} = 60V$, $V_{CM1} = 60V$, $V_{CM2} = 22V$	65	90		dB
Full-scale sense voltage	V_{SENSE}	MPQ8113, $V_{SENSE} = V_{RG1} - V_{RG2}$			80	mV
		MPQ8113A, $V_{SENSE} = V_{RG1} - V_{RG2}$			200	
Input offset voltage ⁽⁷⁾	V_{OS}	$V_{CM} = 12V$, $V_{SENSE1} = 80mV$, $V_{SENSE2} = 20mV$		0.3	1	mV
Input bias current	I_{RG1} , I_{RG2}	$V_{CM} = 12V$		0.25	1	μA
Current-sense gain	G_M	$T_J = 25^{\circ}C$	4.95	5	5.05	A/A
		$T_J = -40^{\circ}C$ to $+125^{\circ}C$	4.9	5	5.1	
Output voltage gain	A_V	MPQ8113, $V_{SENSE} = 80mV$, $V_{CM} = 12V$, $T_J = 25^{\circ}C$	49.5	50	50.5	V/V
		MPQ8113, $V_{SENSE} = 80mV$, $V_{CM} = 12V$, $T_J = -40^{\circ}C$ to $+125^{\circ}C$	49	50	51	
Bandwidth ⁽⁸⁾	BW	$C_{OUT} = 5pF$, $A_V = 50V/V$, ($R_{G1} = R_{G2} = 1k\Omega$, $R_{OUT} = 10k\Omega$), small signal -3dB bandwidth		700		kHz
		$C_{OUT} = 5pF$, $A_V = 20V/V$, ($R_{G1} = R_{G2} = 1k\Omega$, $R_{OUT} = 4k\Omega$), small signal -3dB bandwidth		1400		
Power supply rejection ratio ⁽⁹⁾	PSRR	$V_{CC1} = 60V$, $V_{CC2} = 2.7V$, $V_{SENSE} = 24mV$	70	80		dB
V5 upper threshold voltage	V_{TH_UPPER}		1.3	2	2.5	V
V5 lower threshold voltage	V_{TH_LOWER}		1.2	1.9	2.4	V
V5 shutdown supply current	$I_{CC(SHDN)}$	$V_5 = 1V$		0.2	2	μA

ELECTRICAL CHARACTERISTICS (continued)

$V_{CC} = 12V$, $V_{RG1} = 12V$, $T_A = -40^{\circ}C$ to $+125^{\circ}C$, typical values at $T_J = 25^{\circ}C$. For the MPQ8113, $R_{G1} = R_{G2} = 0\Omega$, and R_{OUT} is not used. For the MPQ8113A, $R_{G1} = R_{G2} = 1k\Omega$, and $R_{OUT} = 10k\Omega$, unless otherwise noted.

Parameter	Symbol	Conditions	Min	Typ	Max	Units
Output respond time ⁽⁸⁾		$R_{G1} = R_{G2} = 1k\Omega$, $R_{OUT} = 10k\Omega$, $V_{SENSE} = 5mV$ to $80mV$, V_{OUT} from 10% to 90%		500		ns
		$R_{G1} = R_{G2} = 1k\Omega$, $R_{OUT} = 10k\Omega$, $V_{SENSE} = 80mV$ to $5mV$, V_{OUT} from 10% to 90%		500		
		$R_{G1} = R_{G2} = 1k\Omega$, $R_{OUT} = 4k\Omega$, $V_{SENSE} = 5mV$ to $100mV$, V_{OUT} from 10% to 90%		250		ns
		$R_{G1} = R_{G2} = 1k\Omega$, $R_{OUT} = 4k\Omega$, $V_{SENSE} = 100mV$ to $5mV$, V_{OUT} from 10% to 90%		250		

Notes:

- 6) $CMR = 20 \times \log[(V_{CM1} - V_{CM2}) / (V_{OUT1} - V_{OUT2})]$. V_{OUT1} is the output voltage at V_{CM1} , and V_{OUT2} is the output voltage at V_{CM2} .
- 7) $V_{OS} = V_{SENSE1} - V_{OUT1} / [(V_{OUT1} - V_{OUT2}) / (V_{SENSE1} - V_{SENSE2})]$. V_{OUT1} is the output voltage at V_{SENSE1} , and V_{OUT2} is the output voltage at V_{SENSE2} .
- 8) Not tested in production. Guaranteed by design and characterization.
- 9) $PSRR = 20 \times \log[(V_{CC1} - V_{CC2}) / (V_{OUT1} - V_{OUT2})]$. V_{OUT1} is the output voltage at V_{CC1} , and V_{OUT2} is the output voltage at V_{CC2} .

TYPICAL CHARACTERISTICS

$V_{CC} = V_{RG1} = 12V$, $V_5 = 5V$, $T_J = -40^{\circ}C$ to $+125^{\circ}C$, unless otherwise noted.

Supply Current vs. Temperature

$I_Q = I_{CC} + I_{V5}$

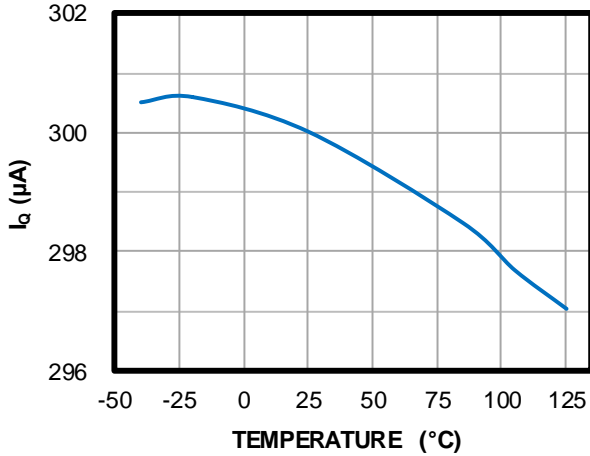

Input Bias Current vs. Temperature

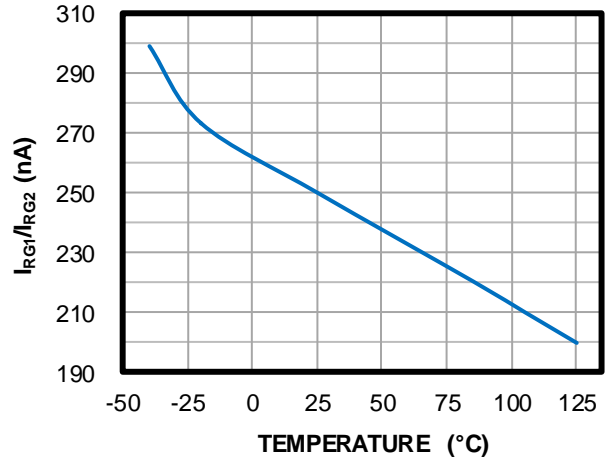

V5 UVLO Threshold vs. Temperature

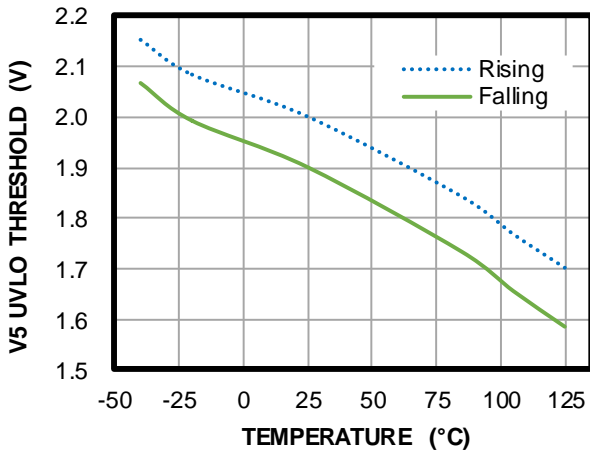

V5 Shutdown Supply Current vs. Temperature

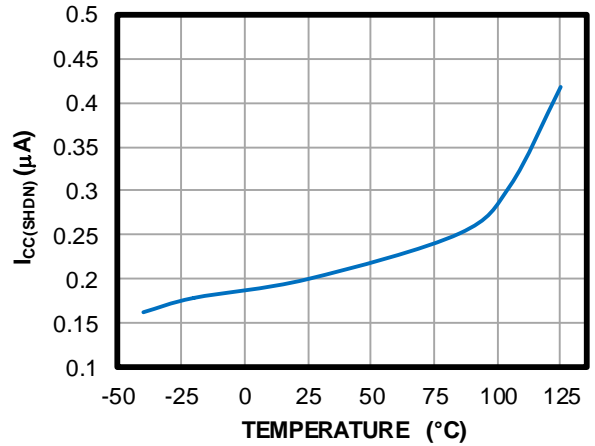

Current-Sense Gain vs. Temperature

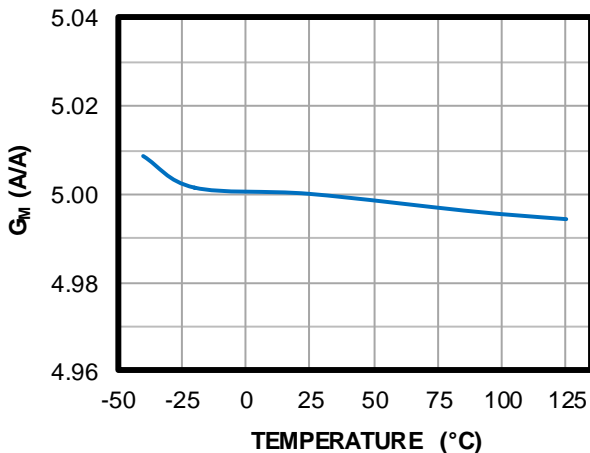

TYPICAL PERFORMANCE CHARACTERISTICS

$V_{CC} = 12V$, $V_{RG1} = 12V$, $V_5 = 5V$, $T_A = 25^\circ C$. For the MPQ8113, $R_{G1} = R_{G2} = 0\Omega$, and R_{OUT} is not used. For the MPQ8113A, $R_{G1} = R_{G2} = 1k\Omega$, and $R_{OUT} = 10k\Omega$, unless otherwise noted.

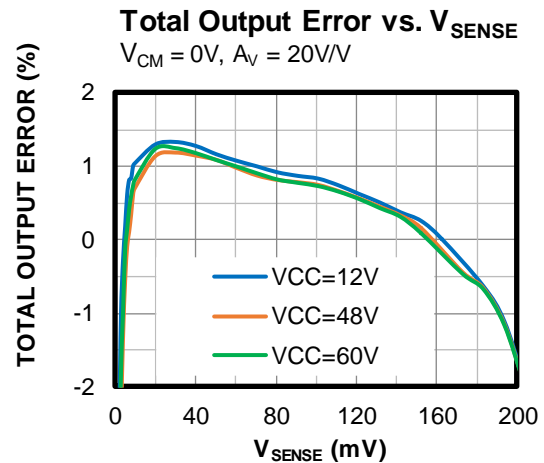
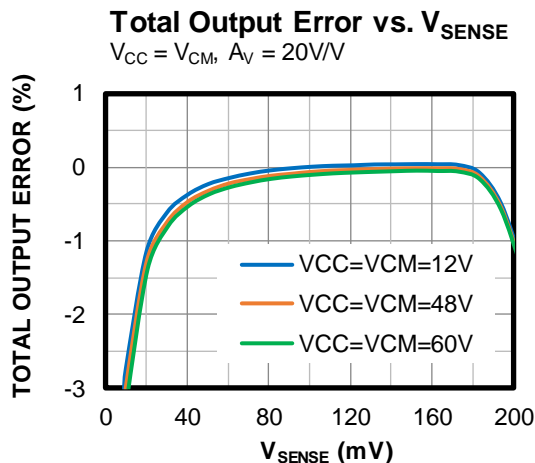
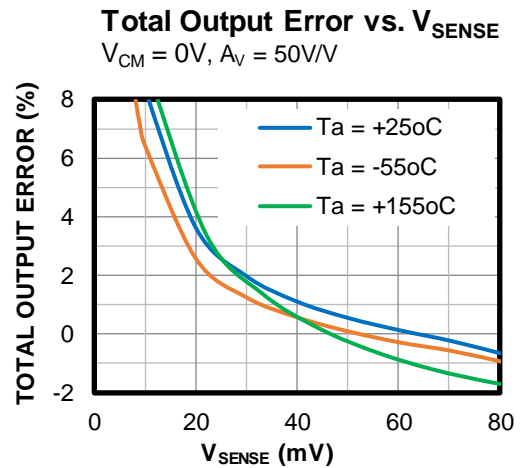
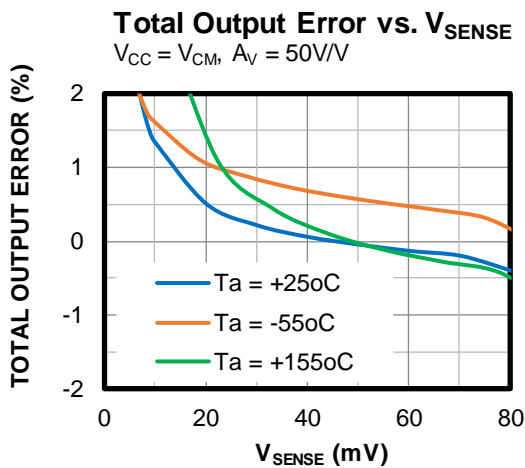
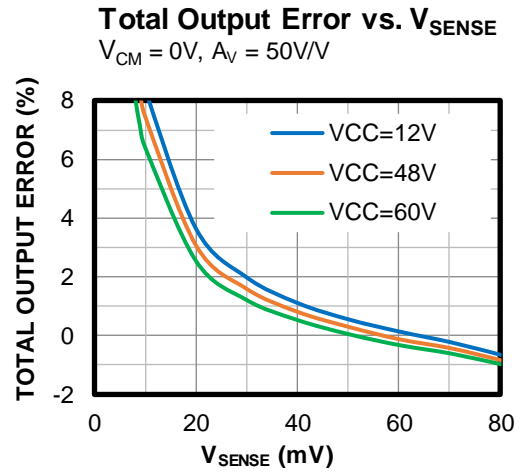
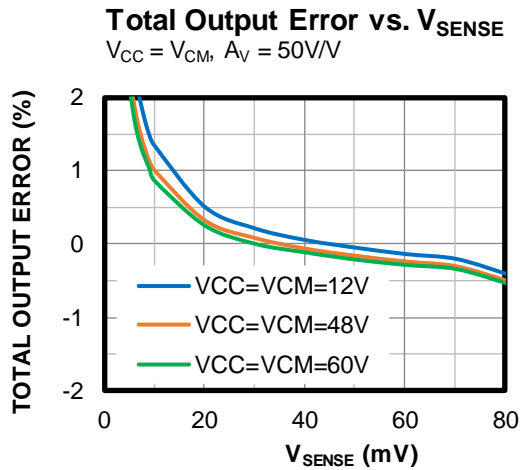

TYPICAL PERFORMANCE CHARACTERISTICS (continued)

$V_{CC} = 12V$, $V_{RG1} = 12V$, $V_5 = 5V$, $T_A = 25^\circ C$. For the MPQ8113, $R_{G1} = R_{G2} = 0\Omega$, and R_{OUT} is not used. For the MPQ8113A, $R_{G1} = R_{G2} = 1k\Omega$, and $R_{OUT} = 10k\Omega$, unless otherwise noted.

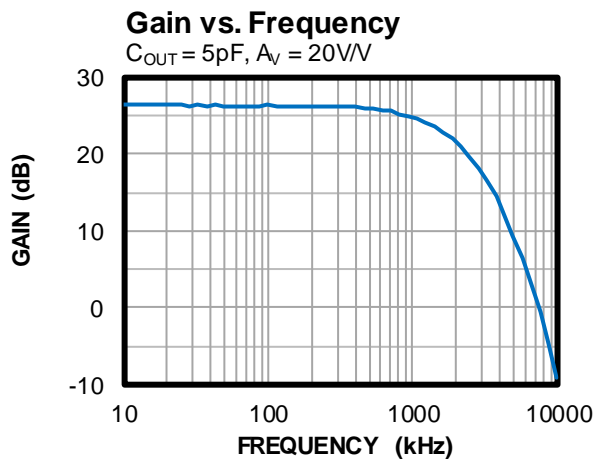
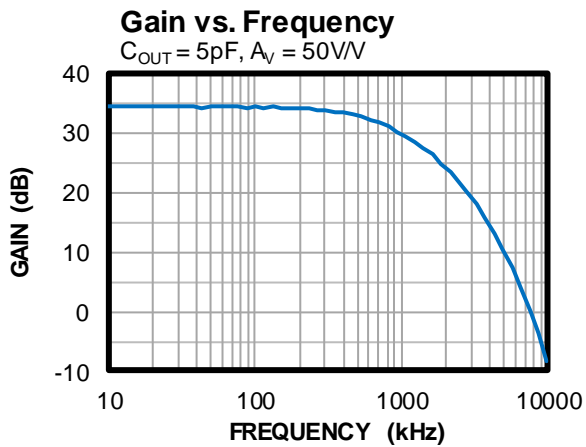
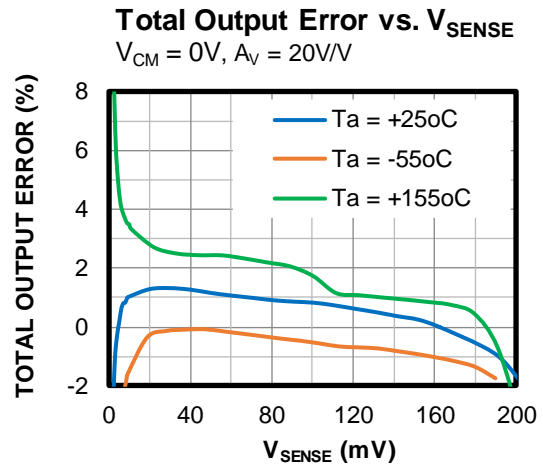
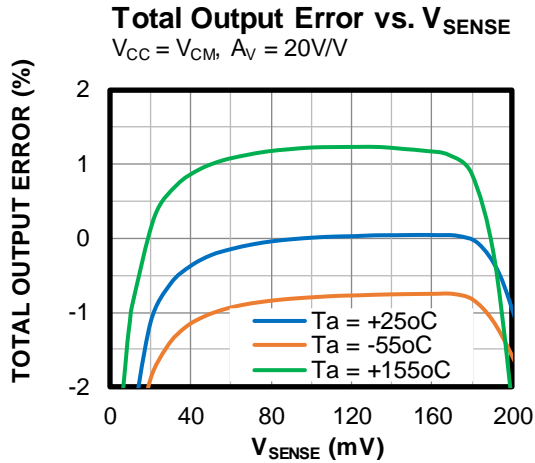

TYPICAL PERFORMANCE CHARACTERISTICS (continued)

$V_{CC} = 12V$, $V_{RG1} = 12V$, $V_5 = 5V$, $T_A = 25^\circ C$. For the MPQ8113, $R_{G1} = R_{G2} = 0\Omega$, and R_{OUT} is not used. For the MPQ8113A, $R_{G1} = R_{G2} = 1k\Omega$, and $R_{OUT} = 10k\Omega$, unless otherwise noted.

Transient Response

$V_{SENSE} = 0mV$ to $40mV$, $A_V = 50V/V$

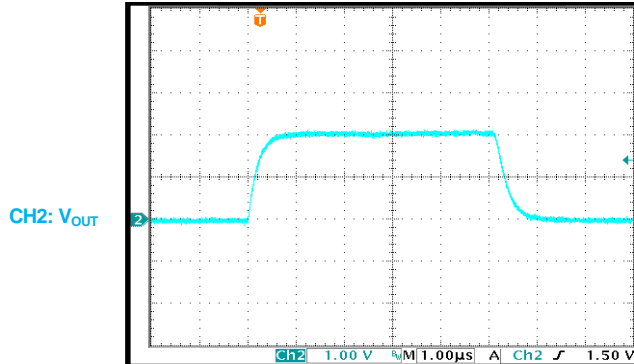

Transient Response

$V_{SENSE} = 0mV$ to $80mV$, $A_V = 50V/V$

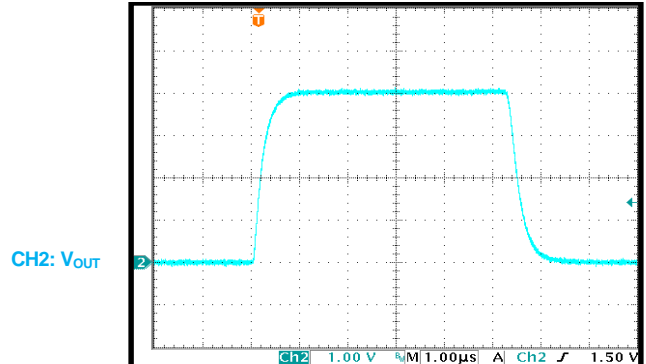

Transient Response

$V_{SENSE} = 40mV$ to $80mV$, $A_V = 50V/V$

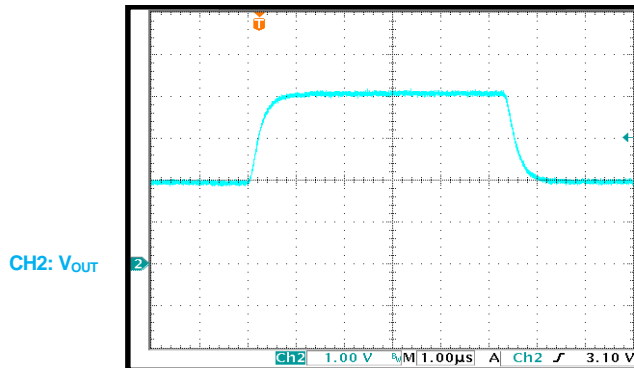

Transient Response

$V_{SENSE} = 0mV$ to $100mV$, $A_V = 20V/V$
(MPQ8113A, $R_{OUT} = 4k\Omega$)

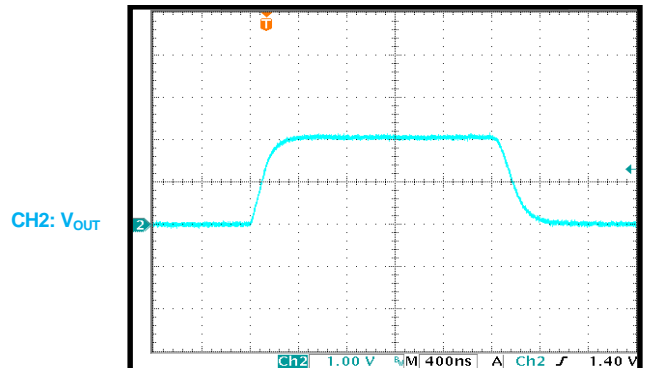

Transient Response

$V_{SENSE} = 0mV$ to $200mV$, $A_V = 20V/V$
(MPQ8113A, $R_{OUT} = 4k\Omega$)

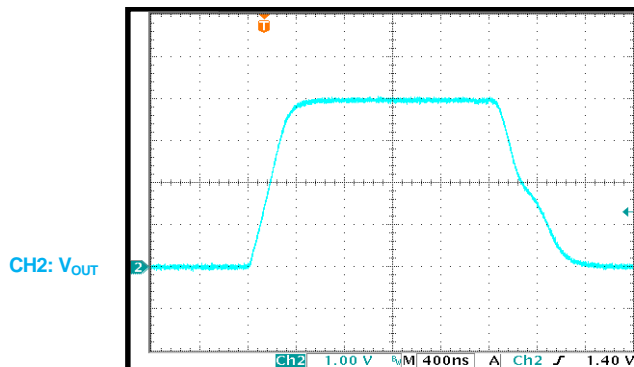

Transient Response

$V_{SENSE} = 100mV$ to $200mV$, $A_V = 20V/V$
(MPQ8113A, $R_{OUT} = 4k\Omega$)

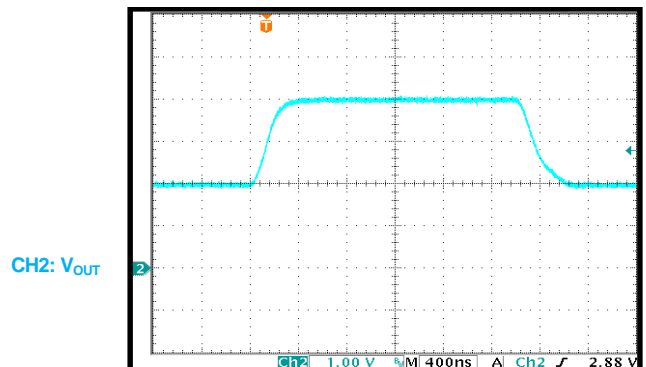

FUNCTIONAL BLOCK DIAGRAMS

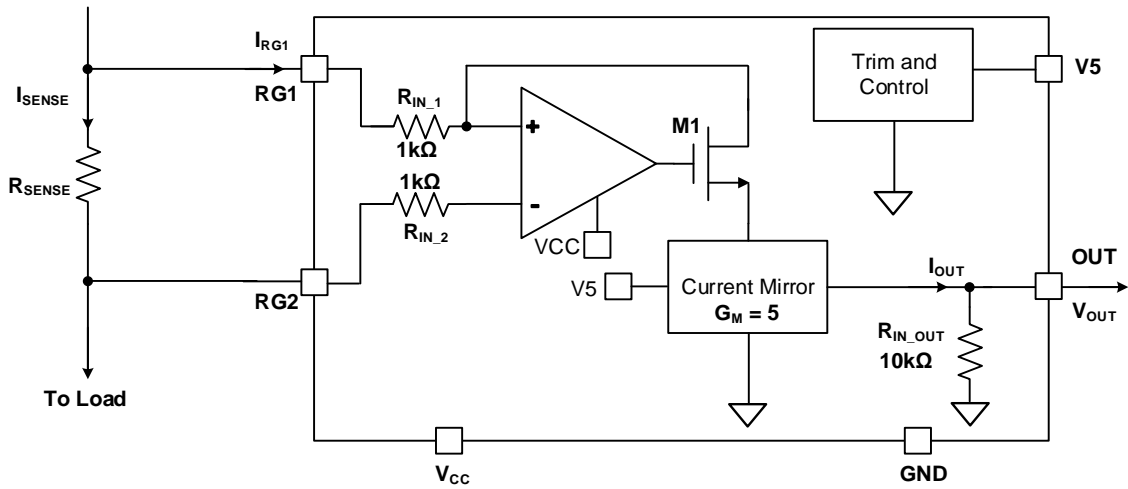

Figure 3: MPQ8113 Functional Block Diagram

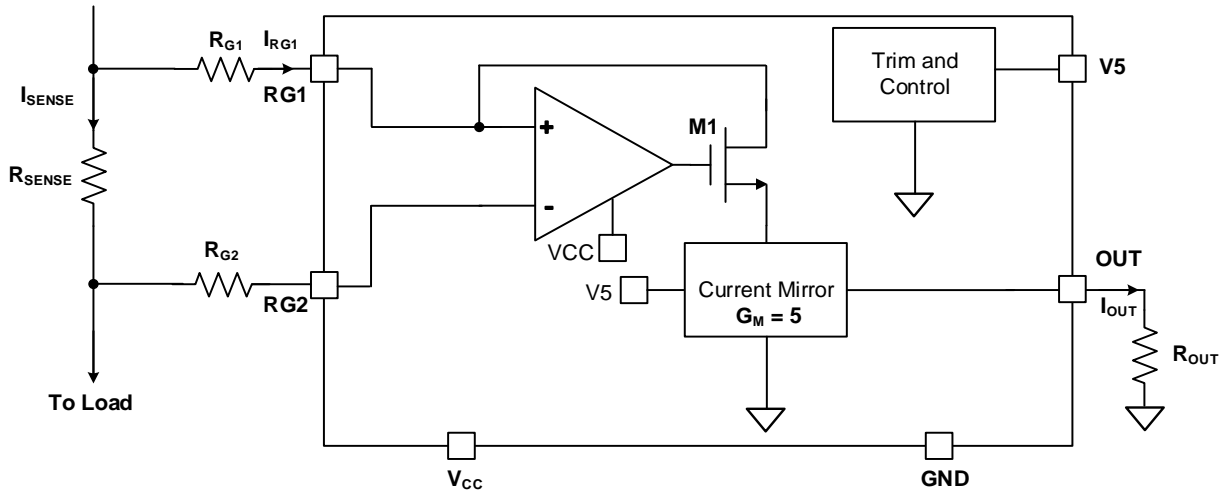

Figure 4: MPQ8113A Functional Block Diagram

OPERATION

The MPQ8113 and MPQ8113A are high-side current-sense amplifiers with a wide 2.7V to 60V operating input voltage (V_{CC}) range. The common mode input voltage (V_{CM}) is based on V_{CC} , with an operating range of $0 \leq V_{CM} \leq V_{CC} \leq 60V$.

The MPQ8113 directly converts a differential input voltage to a voltage output with built-in internal common input resistors and a load resistor. The MPQ8113 has a 50V/V gain.

The MPQ8113A converts the differential input voltage to a current output. This current is converted back to a voltage with an external load resistor. The MPQ8113A has an adjustable gain based on the external common input resistors and load resistor.

Gain Setting

The sense current (I_{SENSE}) flows through the sense resistor (R_{SENSE}), which generates a sense voltage (V_{SENSE}). The high-precision sense amplifier built into the MPQ8113/MPQ8113A monitors the differential voltage (V_{SENSE}) and dynamically adjusts the gate voltage of the internal N-channel MOSFET (M1) to maintain an equal passing current (I_{RG1}). I_{RG1} is then multiplied by a gain factor (G_M) in the output stage current mirror, and finally flows through R_{OUT} to generate V_{OUT} .

The MPQ8113/MPQ8113A's output (V_{OUT}) can be estimated with Equation (1):

$$V_{OUT} = I_{SENSE} \times R_{SENSE} / R_{G1} \times G_M \times R_{OUT} \quad (1)$$

Where G_M is 5A/A, and R_{G1} and R_{OUT} are external resistors for the MPQ8113A. For the MPQ8113, R_{G1} is R_{IN_1} , and R_{OUT} is R_{IN_OUT} . These values are 1k Ω and 10k Ω , respectively.

The total gain (A_V) can be calculated with Equation (2):

$$A_V = V_{OUT} / V_{SENSE} = R_{OUT} / R_{G1} \times G_M \quad (2)$$

The MPQ8113A's gain is adjustable by selecting different combinations of R_{OUT} and R_{G1} . The MPQ8113's gain is fixed to 50V/V, and set by the internal resistors (R_{IN_1} and R_{IN_OUT}).

VCC Supply

The VCC supply is the power source for the internal input stage amplifier. Use a bypass capacitor to ensure stability. Apply a 0.1 μ F to 1 μ F low-ESR ceramic capacitor between VCC and GND, placed as close as possible to the VCC pin. If the VCC power source is noisy, additional capacitance may be required.

Common Input Voltage

The MPQ8113/MPQ8113A's common input voltage ranges between 0V and V_{CC} .

The minimum common input voltage is 0V. If the common input voltage is below 1.2V, an internal, dedicated compensation circuit is activated and drives the M1 drain voltage high enough to make the shunt current (I_{RG1}) pass into the current mirror. The compensation circuit can cause the output error to rise when V_{CM} is below 1.2V (for more information, see the Output Error vs. V_{SENSE} curves in the Typical Performance Characteristics section on page 8).

It is recommended to ensure that the common input voltage (V_{RG1}) does not exceed V_{CC} since V_{RG1} is the positive input of the amplifier, which is powered by V_{CC} .

V5 Supply

V5 supplies the internal control block, as well as the output stage current mirror circuitry. V5 also supplies the compensation circuit when the common input voltage (V_{RG1} / V_{RG2}) is low.

V5 can act like a digital control pin that turns the current-sense amplifier on and off. If V5 is pulled below its 1.9V lower threshold voltage, the chip shuts down. If V5 is pulled above its 2V upper threshold voltage, the part turns on. V5 also operates as the power source for output current mirror circuitry, which means that V5 provides the output current and limits the maximum output voltage to about $V5 - 0.3V$.

Consider the accuracy of the output. It is recommended to design the maximum V_{OUT} such that it does not exceed $V5 - 1V$ with proper R_{SENSE} selection and gain setting.

In addition, if the common input voltage drops below 1.2V, the compensation circuit is activated and drives the M1 drain voltage high enough to make the shunt current (I_{RG1}) pass into the

current mirror. The compensation circuit consumes 0.1mA to 1mA of current when it starts to work. Along with the output current, V5 requires a low-impedance power source with a load capability exceeding 5mA, and a 10nF to 100nF ceramic bypass capacitor.

APPLICATION INFORMATION

Figure 5 shows the typical application circuit for the MPQ8113.

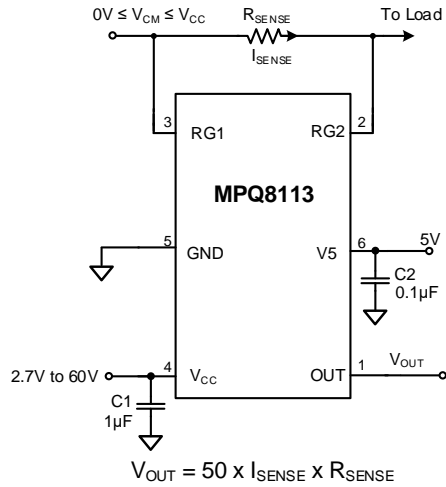

Figure 5: MPQ8113 ($V_{CM} \leq V_{CC}$)

Figure 6 shows the typical application circuit for the MPQ8813A.

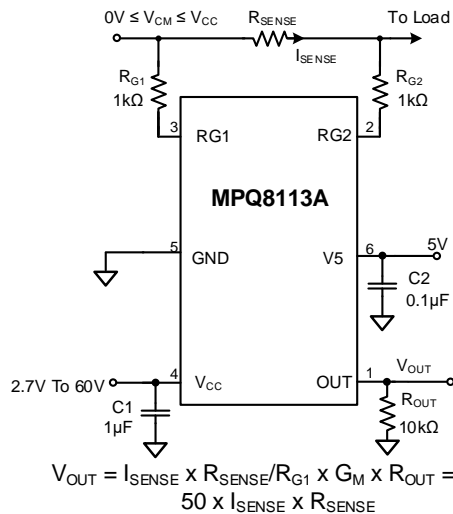

Figure 6: MPQ8113A ($A_V = 50V/V$ with $V_{CM} \leq V_{CC}$)

Table 1: Design Guide Index

Pin #	Name	Components		Design Guide Index
		MPQ8113	MPQ8113A	
1	OUT		R_{OUT}	Setting the Output Gain , Selecting the Gain Resistors and Output Resistors (OUT, Pin 1)
2	RG2	R_{SENSE}	R_{SENSE}, R_{G2}	Setting the Output Gain , Selecting the Gain Resistors and Output Resistors, Selecting the Sensing Resistor (RG2, Pin 2; RG1, Pin 3)
3	RG1	R_{SENSE}	R_{SENSE}, R_{G1}	Setting the Output Gain , Selecting the Gain Resistors and Output Resistors, Selecting the Sensing Resistor (RG2, Pin 2; RG1, Pin 3)
4	VCC	C1	C1	Power Supply (VCC, Pin 4)
5	GND			Connection GND (GND, Pin 5)
6	V5	C2	C2	Enable and Limit the Maximum V_{OUT} (V5, Pin 6)

Setting the Output Gain (OUT, Pin 1; RG2, Pin 2; RG1, Pin 3)

The output voltage of the MPQ8113 and MPQ8113A can be calculated with Equation (3):

$$V_{OUT} = I_{SENSE} \times R_{SENSE} / R_{G1} \times G_M \times R_{OUT} \quad (3)$$

Where $G_M = 5A/A$. The output voltage gain of the MPQ8113/MPQ8113A can be estimated with Equation (4):

$$A_V = V_{OUT} / V_{SENSE} = R_{OUT} / R_{G1} \times G_M \quad (4)$$

The MPQ8113 has a fixed 50V/V A_V with a built-in 1kΩ R_{IN_1} and 10kΩ R_{IN_OUT} . The MPQ8113A's A_V can be adjusted by choosing different values for the external R_{OUT} and R_{G1} . For example, if $R_{G1} = 1k\Omega$ and $R_{OUT} = 4k\Omega$, the MPQ8113A's A_V is equal to 20V/V.

Selecting the Gain Resistors and Output Resistors (OUT, Pin 1; RG2, Pin 2; RG1, Pin 3)

The MPQ8113 has built-in common input and output resistors and a fixed 50V/V gain. It does not require external resistors.

Choose the MPQ8113A's R_{G1} , R_{G2} , and R_{OUT} to provide V_{OUT} with the appropriate full-scale voltage range. Select R_{G1} and R_{G2} first, and ensure that they are below 4kΩ for high current-sense accuracy. It is recommended for R_{G1} and R_{G2} to be 1kΩ. Then R_{OUT} can be calculated with Equation (5):

$$R_{OUT} = V_{OUT} / (I_{SENSE} \times R_{SENSE} / R_{G1} \times G_M) \quad (5)$$

Selecting the Sensing Resistor (RG2, Pin 2; RG1, Pin 3)

Given a full-scale sense current, select R_{SENSE} so that V_{SENSE} does not exceed 200mV, which is the maximum voltage for accurate measurements. To measure lower currents more accurately, use a larger-value R_{SENSE} . A larger-value resistor results in a higher sense voltage, which overcomes offset voltage errors on the internal current amplifier. However, high R_{SENSE} values also introduce high losses.

R_{SENSE} selection is a tradeoff between accuracy and losses. In most applications, choose an R_{SENSE} value that provides a full-scale V_{SENSE} voltage range between 50mV and 200mV.

In applications that monitor very high currents, ensure that R_{SENSE} is able to dissipate its own I^2R losses. If the resistor's power rating is exceeded, its value may drift, or it may fail altogether. This causes a differential voltage across the terminals that exceeds the high absolute maximum range (0.4V).

V_{SENSE} Voltage Protection

Figure 7 shows that the device has built-in back-to-back diodes between R_{G1} and R_{G2} . These diodes have a typical clamping voltage of ±400mV, and a 100mA sink current capacity. Under fault conditions where V_{SENSE} exceeds 400mV or drops below -400mV, the MPQ8113A avoids damage by designing the external resistors (R_{G1} and R_{G2}) to limit the back-to-back diodes' sink current below 100mA.

The MPQ8113 also avoids damage with external resistors (R_{G1} and R_{G2}), but its output gain and accuracy are affected by the different performance between the external and internal resistors.

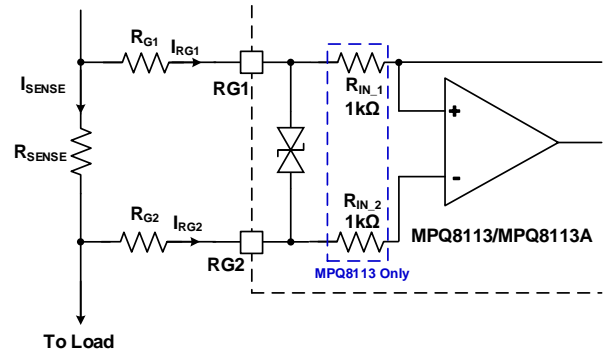

Figure 7: Back-to-Back Diodes

Enable and Limit the Maximum V_{OUT} (V5, Pin 6)

Enable/Disable Control

V5 can act as a digital control pin that turns the current amplifier on and off. Pull V5 above its 2V upper threshold to enable the part. Pull V5 below its 1.9V lower threshold to disable the part. When part is disabled, V_{OUT} is pulled down to 0V.

It is recommended to enable the device before the sensed main circuit turns on, and to disable the device after the sensed main circuit turns off.

Supply Source at Low V_{CM}

V5 supplies the internal control block and output stage current mirror circuitry. It also supplies the compensation circuit when the common input voltage (V_{RG1} / V_{RG2}) is below 1.2V. V5 requires a low-impedance power source with a load capability that exceeds 5mA, and a 10nF to 100nF ceramic bypass capacitor.

Limit the Maximum V_{OUT}

The maximum output voltage (V_{OUT_MAX}) is limited by V5 and the maximum output current (I_{OUT_MAX}). Calculate V_{OUT_MAX} with Equation (6) and Equation (7), then use the lower value as the maximum output voltage:

$$V_{OUT_MAX} = V5 - 0.3V \quad (6)$$

$$V_{OUT_MAX} = R_{OUT} \times I_{OUT_MAX} \quad (7)$$

Where I_{OUT_MAX} is 2mA when V5 = 5V.

I_{OUT_MAX} decreases as V5 ramps down. When V5 equals 3.3V, I_{OUT_MAX} is approximately 1mA. It is recommended to connect V5 to a 5V voltage source to achieve the widest V_{OUT} range.

In addition, consider the output accuracy output. Use a proper R_{SENSE} and gain setting to design the maximum V_{OUT} such that it does not exceed $V5 - 1V$.

Power Supply (VCC, Pin 4)

The VCC supply is the power source for the internal input stage amplifier. Use a bypass capacitor to ensure stability. Apply a 0.1µF to 1µF low-ESR ceramic capacitor between VCC and GND, and placed as close as possible to the VCC pin. If the VCC power source is noisy, additional capacitance may be required.

GND Connection (GND, Pin 5)

For more details on the GND connection, see the PCB Layout Guidelines section below.

PCB Layout Guidelines ⁽¹⁰⁾

Efficient PCB layout, especially for the sensing resistor and output resistor placement, affects accuracy measurement. For the best results, refer to Figure 8 and follow the guidelines below:

1. To minimize any resistance in series with the sensing resistor trace, place the RG1 and RG2 pins as close as possible to the sensing resistor.
2. Connect the bypass capacitors close to the device's pins to decouple the power supply noise.

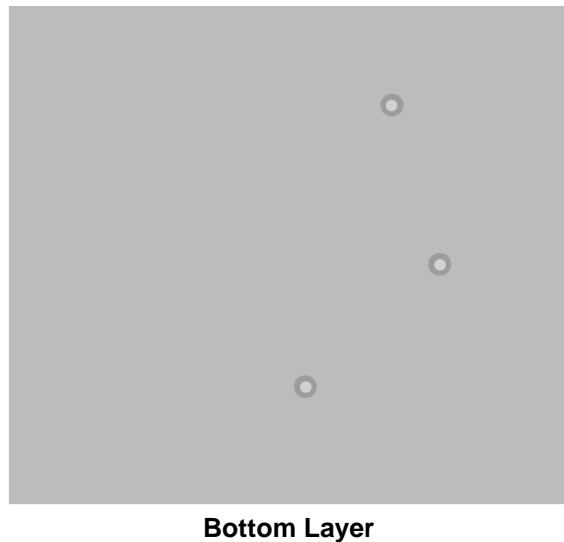
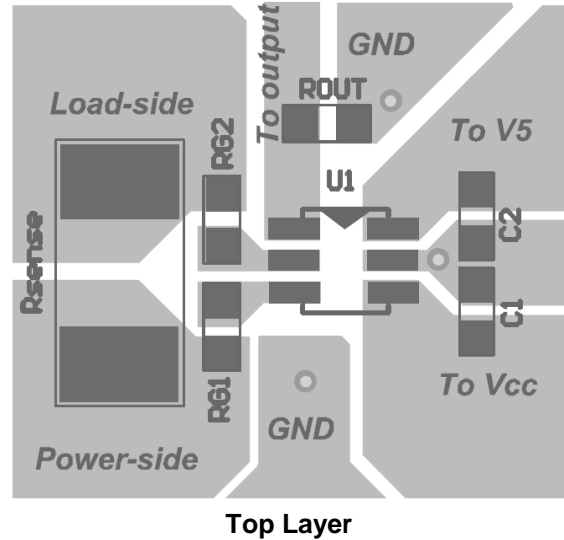
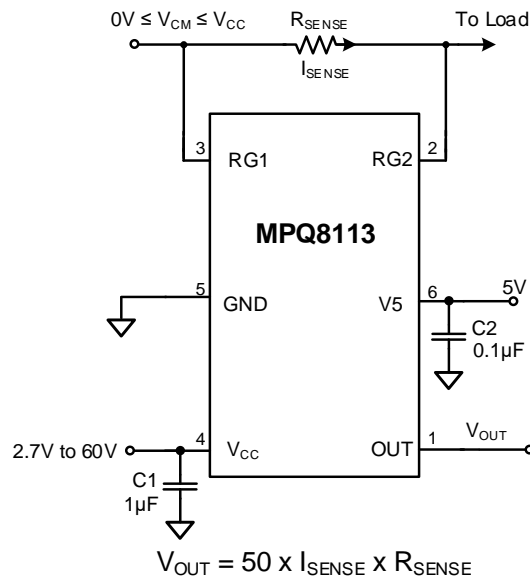
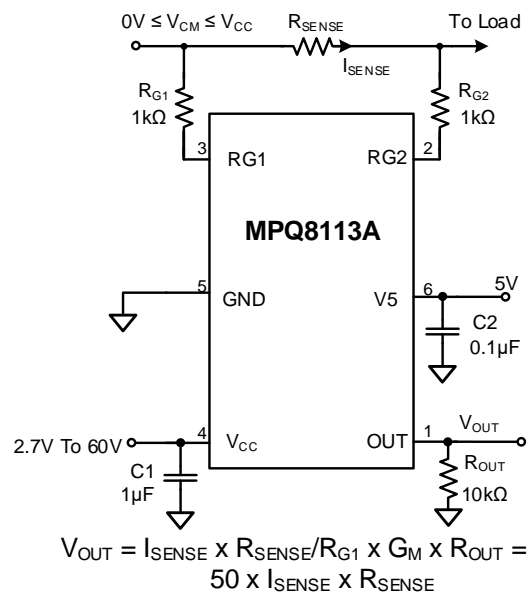

Figure 8: Recommended PCB Layout

Note:

10) The recommended PCB layout is based on Figure 10.

TYPICAL APPLICATION CIRCUITS

Figure 9: MPQ8113 ($V_{CM} \leq V_{CC}$)

Figure 10: MPQ8113A ($A_V = 50V/V$ with $V_{CM} \leq V_{CC}$)

TYPICAL APPLICATION CIRCUITS (continued)

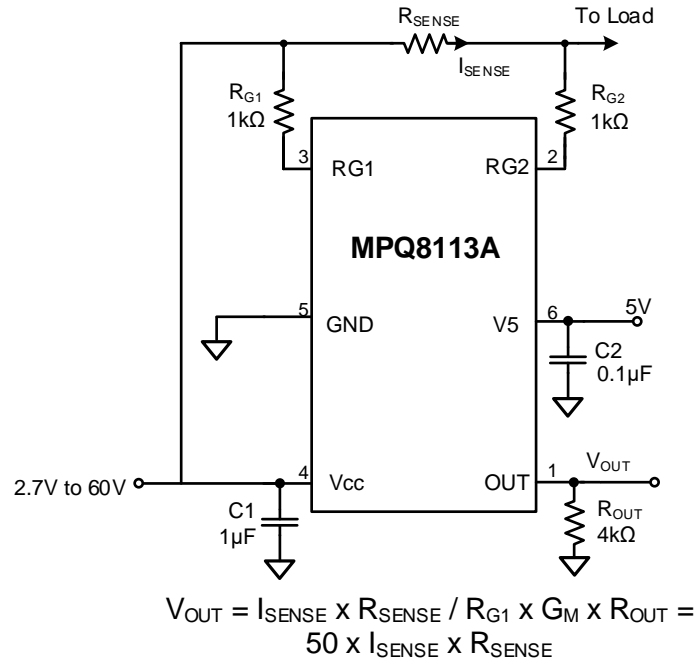
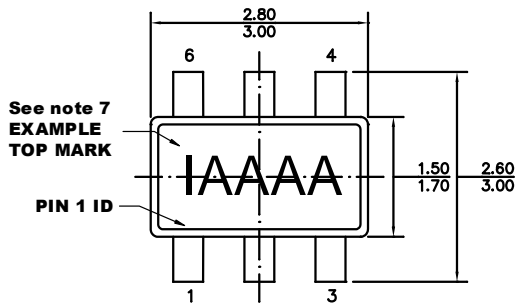
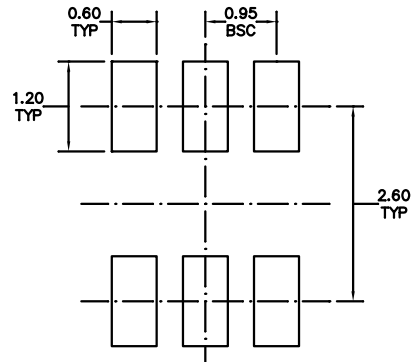
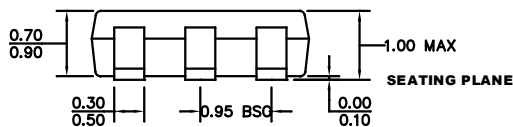
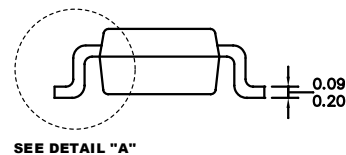

Figure 11: MPQ8113A ($A_v = 20V/V$ with $V_{CM} = V_{CC}$)

PACKAGE INFORMATION

TSOT23-6L

TOP VIEW

RECOMMENDED LAND PATTERN

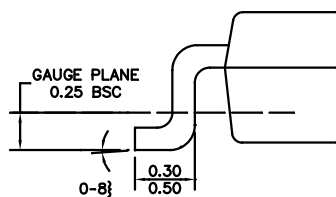
FRONT VIEW

SEE DETAIL "A"

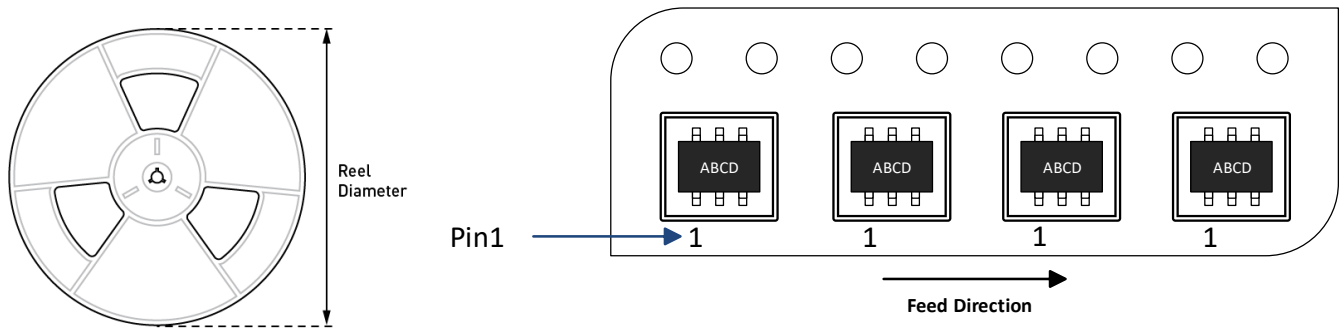
SIDE VIEW

DETAIL "A"
NOTE:

- 1) ALL DIMENSIONS ARE IN MILLIMETERS.
- 2) PACKAGE LENGTH DOES NOT INCLUDE MOLD FLASH, PROTRUSION, OR GATE BURR.
- 3) PACKAGE WIDTH DOES NOT INCLUDE INTERLEAD FLASH OR PROTRUSION.
- 4) LEAD COPLANARITY (BOTTOM OF LEADS AFTER FORMING) SHALL BE 0.10 MILLIMETERS MAX.
- 5) DRAWING CONFORMS TO JEDEC MO-193, VARIATION AB.
- 6) DRAWING IS NOT TO SCALE.
- 7) PIN 1 IS THE LOWER-LEFT PIN WHEN READING THE TOP MARK FROM LEFT TO RIGHT (SEE EXAMPLE TOP MARK).

CARRIER INFORMATION

Part Number	Package Description	Quantity/ Reel	Quantity/ Tube	Quantity/ Tray	Reel Diameter	Carrier Tape Width	Carrier Tape Pitch
MPQ8113GJ-AEC1-Z	TSOT23-6L	3000	N/A	N/A	7in	8mm	4mm
MPQ8113AGJ-AEC1-Z							

REVISION HISTORY

Revision #	Revision Date	Description	Pages Updated
1.0	06/10/2021	Initial Release	-

Notice: The information in this document is subject to change without notice. Users should warrant and guarantee that third-party Intellectual Property rights are not infringed upon when integrating MPS products into any application. MPS will not assume any legal responsibility for any said applications.