

DESCRIPTION

The MP6610 is a half-bridge driver with current measurement and regulation features. It can deliver up to 3A of output current across a wide 4V to 55V input voltage range. The MP6610 is designed to drive brushed DC motors, solenoids, and other loads.

An internal current-sense circuit provides an output voltage that is proportional to the load current. The MP6610 also features cycle-by-cycle current limiting and regulation. These features do not require the use of a low-ohmic shunt resistor.

Internal diagnostic and protection features include open-load detection (OLD), over-current protection (OCP), under-voltage lockout (UVLO), and thermal shutdown.

The MP6610 is available in 8-pin TSOT23-8 and SOIC-8 packages. Due to the small pin spacing, the TSOT23-8 package is only recommended for applications up to 45V, unless conformal coating or encapsulation is used.

FEATURES

- Wide 4V to 55V Operating Input Voltage
- Up to 3A Output Current
- Internal Half-Bridge Driver
- Cycle-by-Cycle Current Limiting and Regulation
- Low On Resistance:
 - 100mΩ High-Side MOSFET (HS-FET)
 - 120mΩ Low-Side MOSFET (LS-FET)
- No Control Power Supply Required
- Simple, Versatile Logic Interfaces
- Inputs Compatible with 2.5V, 3.3V, and 5V Logic
- Open-Load Detection (OLD), Over-Current Protection (OCP), Under-Voltage Lockout (UVLO), and Thermal Shutdown
- Fault Indication Output
- Thermally Enhanced Package
- Available in TSOT23-8 and SOIC-8 Packages

APPLICATIONS

- Solenoid Drivers
- Relay Drivers
- Brushed DC Motor Drivers

All MPS parts are lead-free, halogen-free, and adhere to the RoHS directive. For MPS green status, please visit the MPS website under Quality Assurance. "MPS", the MPS logo, and "Simple, Easy Solutions" are trademarks of Monolithic Power Systems, Inc. or its subsidiaries.

TYPICAL APPLICATION

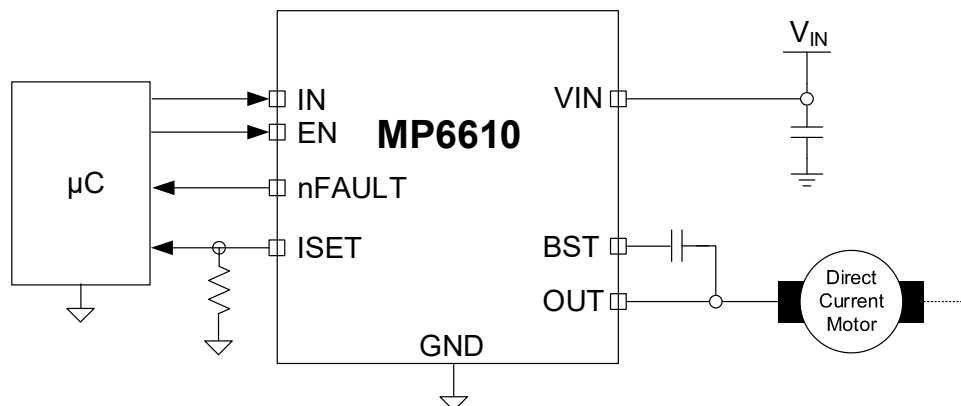

ORDERING INFORMATION

Part Number*	Package	Top Marking	MSL Rating
MP6610GJ*	TSOT23-8	See Below	1
MP6610GS**	SOIC-8	See Below	

* For Tape & Reel, add suffix -Z (e.g. MP6610GJ-Z).

** For Tape & Reel, add suffix -Z (e.g. MP6610GS-Z).

TOP MARKING (MP6610GJ)

| AVRY

AVR: Product code of MP6610GJ

Y: Year code

TOP MARKING (MP6610GS)

MP6610
LLLLLLLL
MPSYWW

MP6610: Part number

LLLLLLLL: Lot number

MPS: MPS prefix

Y: Year code

WW: Week code

PACKAGE REFERENCE

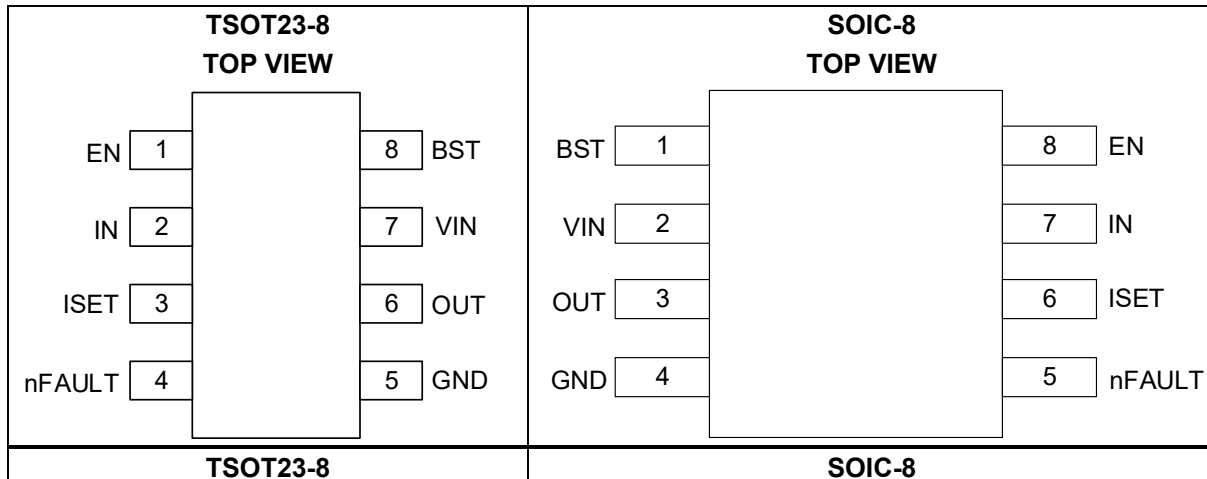

PIN FUNCTIONS

Pin # (TSOT23-8)	Pin # (SOIC-8)	Name	Description
1	8	EN	Half-bridge enable input. Pull the EN pin high to turn the half-bridge driver on; pull EN low to turn it off. EN is pulled down via an internal resistor.
2	7	IN	Half-bridge input. Pull the IN pin high to drive the output high; pull IN low to force the output low. IN is pulled down via an internal resistor.
3	6	ISET	Current configuration resistor. To set the current limit and ISET pin voltage scaling, connect a resistor from ISET to ground.
4	5	nFAULT	Fault indication. The nFAULT pin is an open-drain. If a fault condition (e.g. over-current protection (OCP), over-temperature protection (OTP), or open load) is triggered, nFAULT goes logic low.
5	4	GND	System ground.
6	3	OUT	Output terminal.
7	2	VIN	Input supply voltage. Use a 100nF or greater ceramic capacitor to decouple VIN to GND.
8	1	BST	Bootstrap. Connect a 100nF capacitor between the BST and OUT pins.

ABSOLUTE MAXIMUM RATINGS ⁽¹⁾

Supply voltage (V_{IN})	-0.3V to +65V
Output voltage (V_{OUT})	-0.7V to +65V
BST	V_{IN} to ($V_{IN} + 5.7V$)
ISET	-0.3V to +5.5V
All other pins to GND	-0.3V to +6.5V
Continuous power dissipation ($T_A = 25^\circ C$) ⁽²⁾	
TSOT23-8	1.25W
SOIC-8	1.302W
Storage temperature	-55°C to +150°C
Junction temperature	150°C
Lead temperature (solder)	260°C

ESD Ratings

Human body model (HBM)	2kV
Charged device model (CDM)	±750V

Recommended Operating Conditions ⁽³⁾

Supply voltage (V_{IN}) (SOIC-8)	4V to 55V
Supply voltage (V_{IN}) (TSOT23-8)	4V to 45V
Output current (I_{OUT})	±3A
Operating junction temp (T_J)	-40°C to +125°C

Thermal Resistance ⁽⁴⁾ θ_{JA} θ_{JC}

TSOT23-8 package	100	55	°C/W
SOIC-8 package	96	45	°C/W

Notes:

- Exceeding these ratings may damage the device.
- The maximum allowable power dissipation is a function of the maximum junction temperature T_J (MAX), the junction-to-ambient thermal resistance θ_{JA} , and the ambient temperature T_A . The maximum allowable continuous power dissipation at any ambient temperature is calculated by P_D (MAX) = $(T_J$ (MAX) - T_A) / θ_{JA} . Exceeding the maximum allowable power dissipation can cause excessive die temperature, and the regulator may go into thermal shutdown. Internal thermal shutdown circuitry protects the device from permanent damage.
- The device is not guaranteed to function outside of its operating conditions.
- Measured on JESD51-7, 4-layer PCB.

ELECTRICAL CHARACTERISTICS

$V_{IN} = 24V$, $T_A = -40^{\circ}C$ to $+125^{\circ}C$, unless otherwise noted.

Parameter	Symbol	Condition	Min	Typ	Max	Units
Power Supply						
Input supply voltage	V_{IN}	SOIC-8 package	4		55	V
		TSOT23-8 package	4		45	
Quiescent current	I_Q	$V_{IN} = 24V$, $V_{EN} = 0V$, no load current		1.3	5	mA
Internal MOSFETs						
High-side MOSFET (HS-FET) output on resistance	$R_{DS(ON)_{HS}}$	$V_{IN} = 24V$, $I_{OUT} = 1A$, $T_J = 25^{\circ}C$		100	120	m Ω
Low-side MOSFET (LS-FET) output on resistance	$R_{DS(ON)_{LS}}$	$V_{IN} = 24V$, $I_{OUT} = 1A$, $T_J = 25^{\circ}C$		120	150	m Ω
Body diode forward voltage	V_F	$I_{OUT} = 1A$			1.1	V
Control Logic						
Input logic high threshold	V_{IN_HIGH}		2			V
Input logic low threshold	V_{IN_LOW}				0.8	V
Logic high input current	I_{IN_HIGH}	$V_{IN_HIGH} = 5V$	6		14	μA
Logic low input current	I_{IN_LOW}	$V_{IN_LOW} = 0.8V$			4	μA
Internal pull-down resistance	R_{PD}			530		k Ω
nFault Output (Open-Drain Output)						
Output low voltage	V_{OUT_LOW}	$I_{OUT} = 5mA$			0.8	V
Output high leakage current	I_{OUT_LK}	$V_{OUT} = 3.3V$			1	μA
Protection Circuits						
Under-voltage lockout (UVLO) rising threshold	V_{UVLO_RISING}				4.1	V
UVLO threshold hysteresis	V_{UVLO_HYS}			300		mV
Over-voltage protection (OVP) rising threshold	V_{OVP_RISING}		55		65	V
OVP threshold hysteresis	V_{OVP_HYS}			900		mV
Over-current protection (OCP) trip level	I_{OCP1}	Sink	3			A
	I_{OCP2}	Source	3			A
OCP deglitch time ⁽⁵⁾	t_{OCP}			1		μs
OCP retry time	t_{OCP_RETRY}			1.6		ms
Thermal shutdown	T_{SD}			165		$^{\circ}C$
Thermal shutdown hysteresis	ΔT_{SD_HYS}			15		$^{\circ}C$
Current open-load detection (OLD)	I_{OLD}			90		μA
OLD threshold	V_{OLD}	V_{OUT} is low	1		1.5	V
		V_{OUT} is high, $V_{IN} = 24V$	21.5		23.2	

ELECTRICAL CHARACTERISTICS (continued)
 $V_{IN} = 24V$, $T_A = -40^{\circ}C$ to $+125^{\circ}C$, unless otherwise noted.

Parameter	Symbol	Condition	Min	Typ	Max	Units
Current Control						
Off time	t_{OFF}	After V_{TRIP} is reached		16.5		μs
Blanking time	t_{BLANK}			1		μs
ISET current	I_{SET}	HS-FET source, $I_{OUT} = 1A$	69	90	118	$\mu A/A$
		HS-FET sink, $I_{OUT} = 1A$	82	102	131	
		LS-FET source, $I_{OUT} = 1A$	83	104	130	
		LS-FET sink, $I_{OUT} = 1A$	82	103	129	
Current trip voltage	V_{TRIP}	At ISET pin	1.4	1.5	1.6	V

Notes:

5) Not tested in production.

TYPICAL CHARACTERISTICS

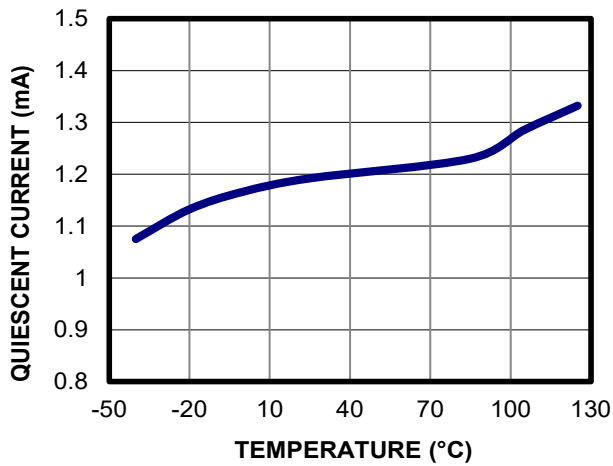
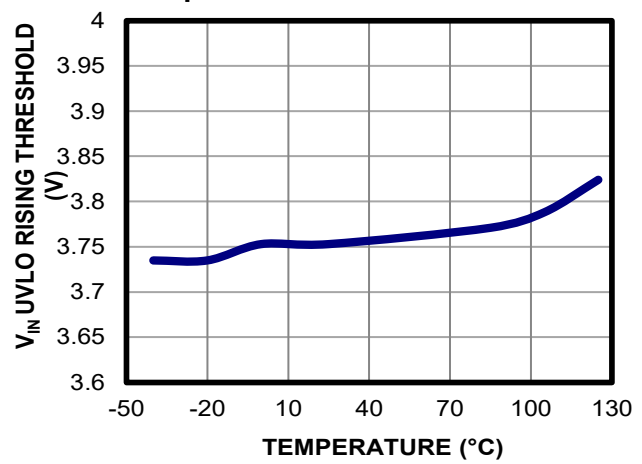
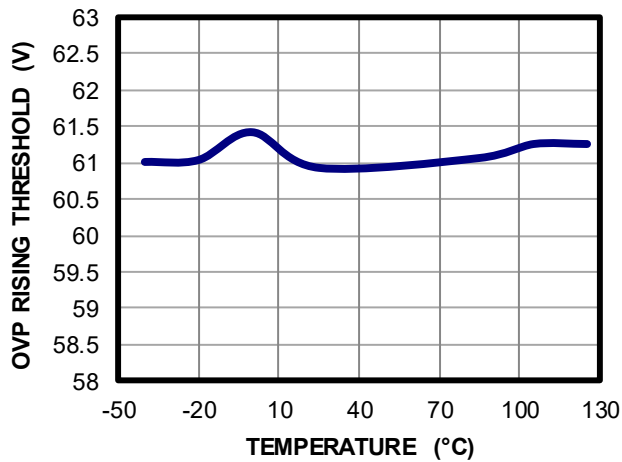
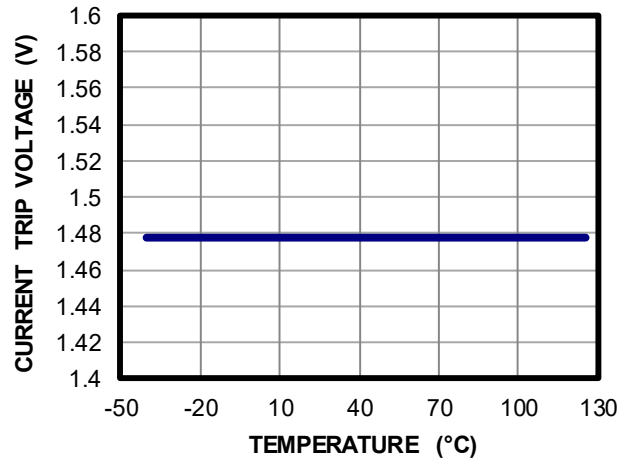
Quiescent Current vs. Temperature
 $V_{IN} = 24V$

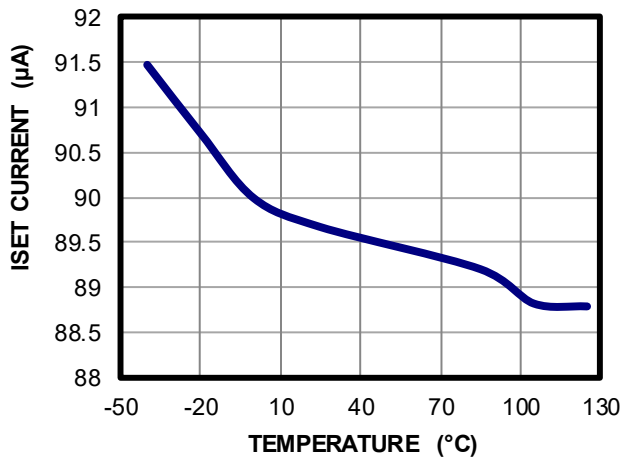
 V_{IN} UVLO Rising Threshold vs. Temperature

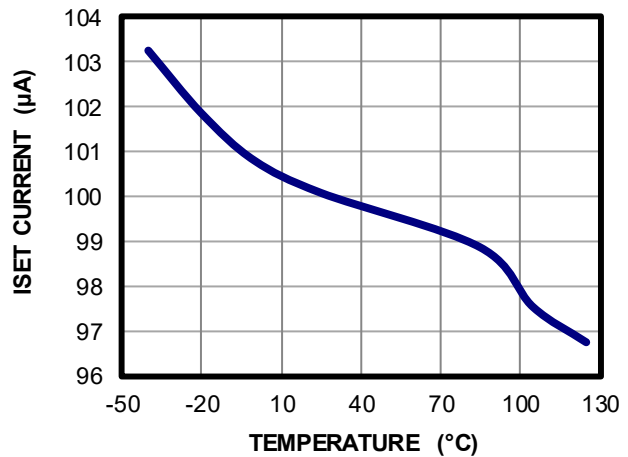
OVP Rising Threshold vs. Temperature

Current Trip Voltage vs. Temperature

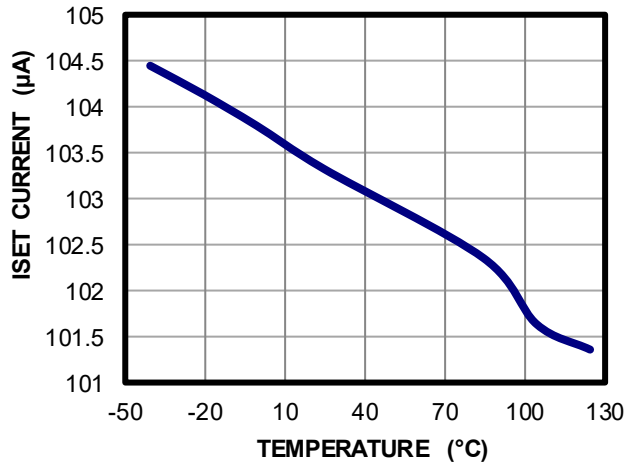
ISET Current vs. Temperature

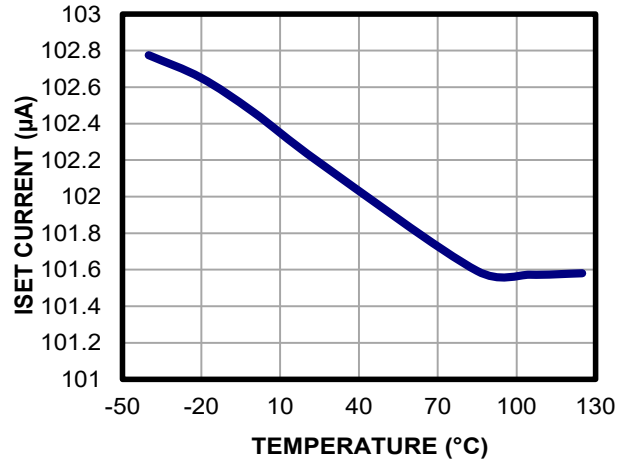
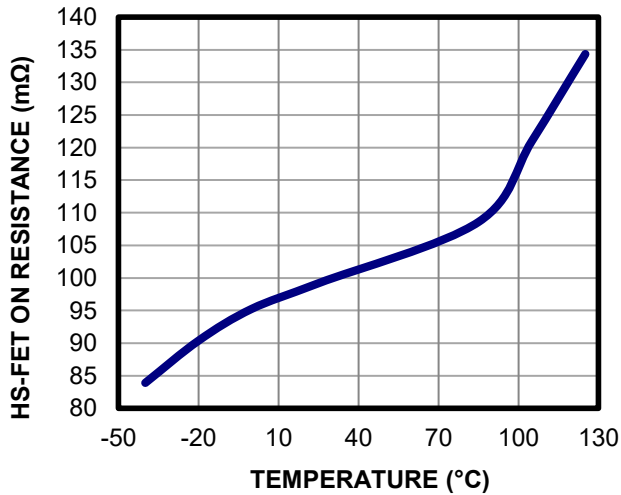
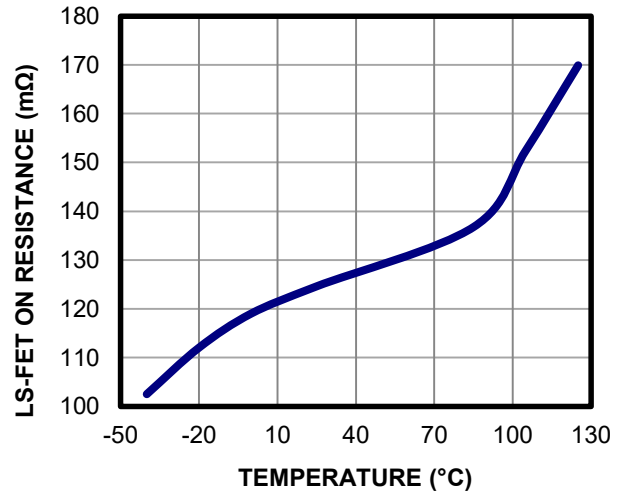
 HS-FET source current, $I_{OUT} = 1A$

ISET Current vs. Temperature

 HS-FET sink current, $I_{OUT} = 1A$

TYPICAL CHARACTERISTICS (continued)
ISET Current vs. Temperature

 LS-FET source current, $I_{OUT} = 1A$

ISET Current vs. Temperature

 LS-FET sink current, $I_{OUT} = 1A$

HS-FET On Resistance vs. Temperature
 $I_{OUT} = 1A$

LS-FET On Resistance vs. Temperature
 $I_{OUT} = 1A$

TYPICAL PERFORMANCE CHARACTERISTICS

$V_{IN} = 24V$, EN is high, IN = 20kHz at 50% duty, $R_{ISET} = 10k\Omega$, resistor + inductor load = $10\Omega + 2mH$, $T_A = 25^\circ C$, unless otherwise noted.

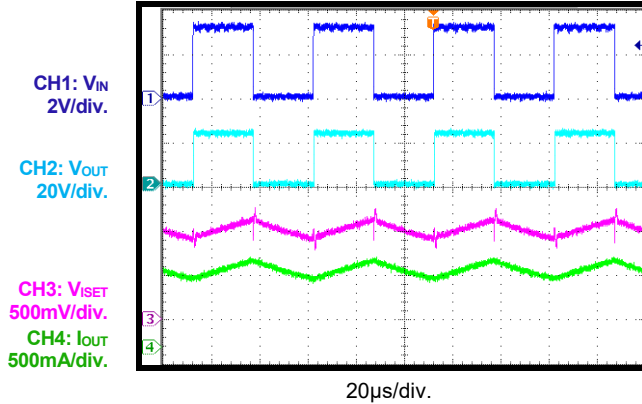
Steady State

Load to GND



Steady State

Load to VIN

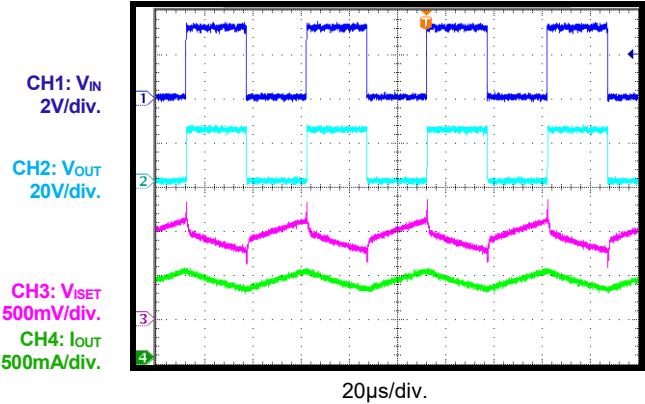

Power Ramps Up

Load to GND

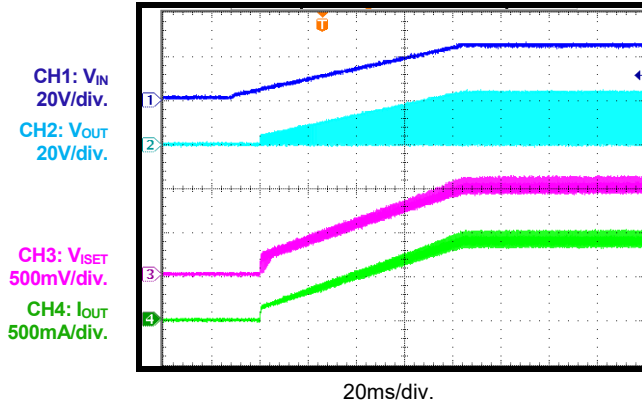

Power Ramps Up

Load to VIN

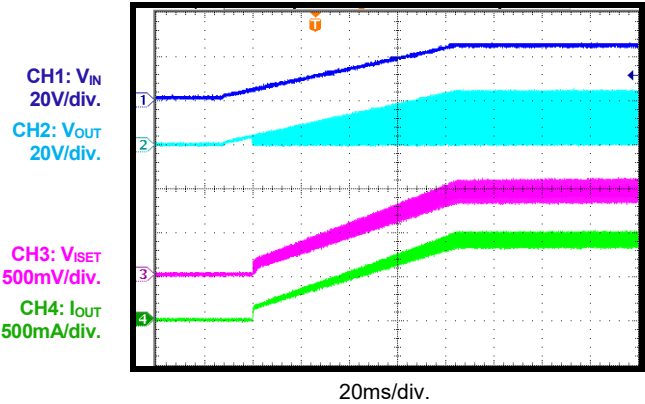

Power Ramps Down

Load to GND

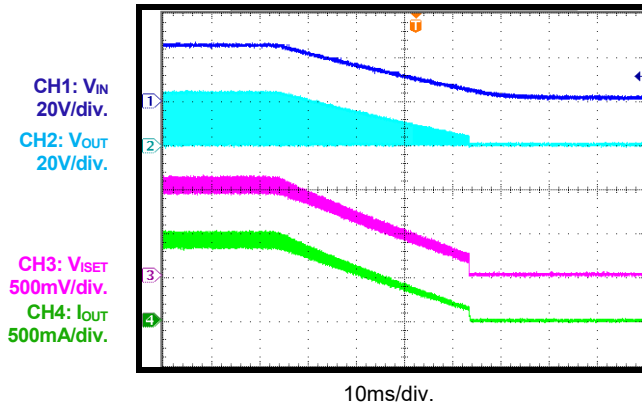

Power Ramps Down

Load to VIN

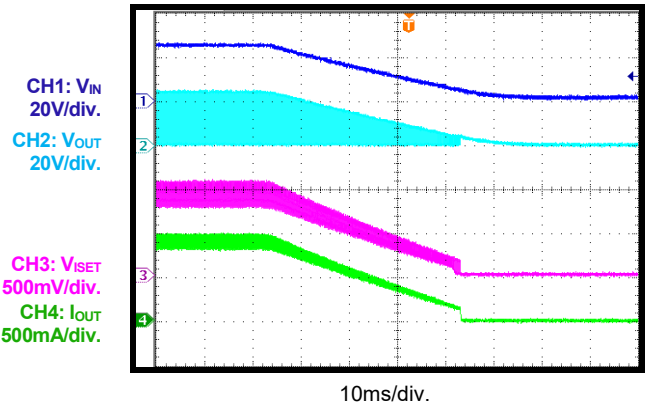

TYPICAL PERFORMANCE CHARACTERISTICS (continued)

$V_{IN} = 24V$, EN is high, $I_N = 20kHz$ at 50% duty, $R_{ISET} = 10k\Omega$, resistor + inductor load = $10\Omega + 2mH$, $T_A = 25^\circ C$, unless otherwise noted.

Start-Up through EN
 Load to GND

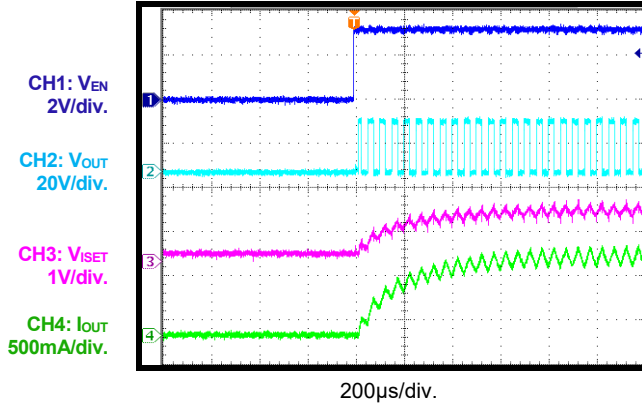

Start-Up through EN
 Load to VIN

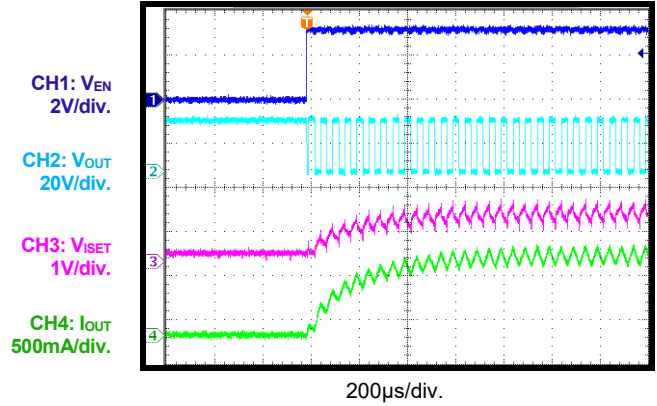

Shutdown through EN
 Load to GND

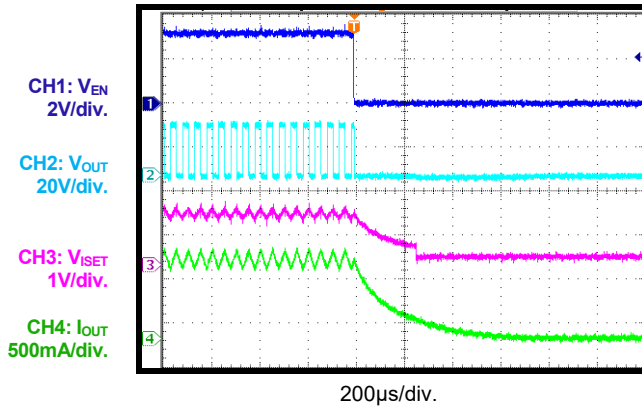

Shutdown through EN
 Load to VIN

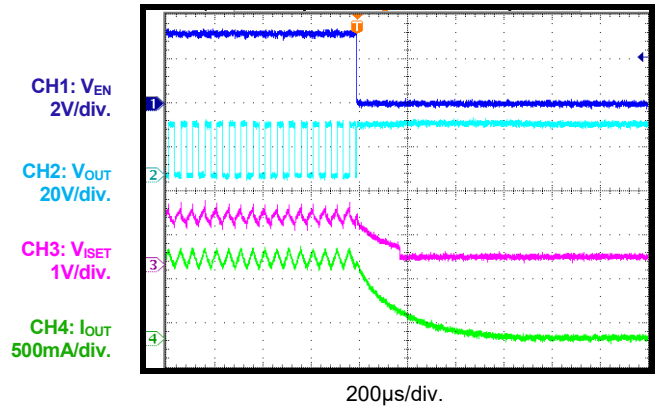

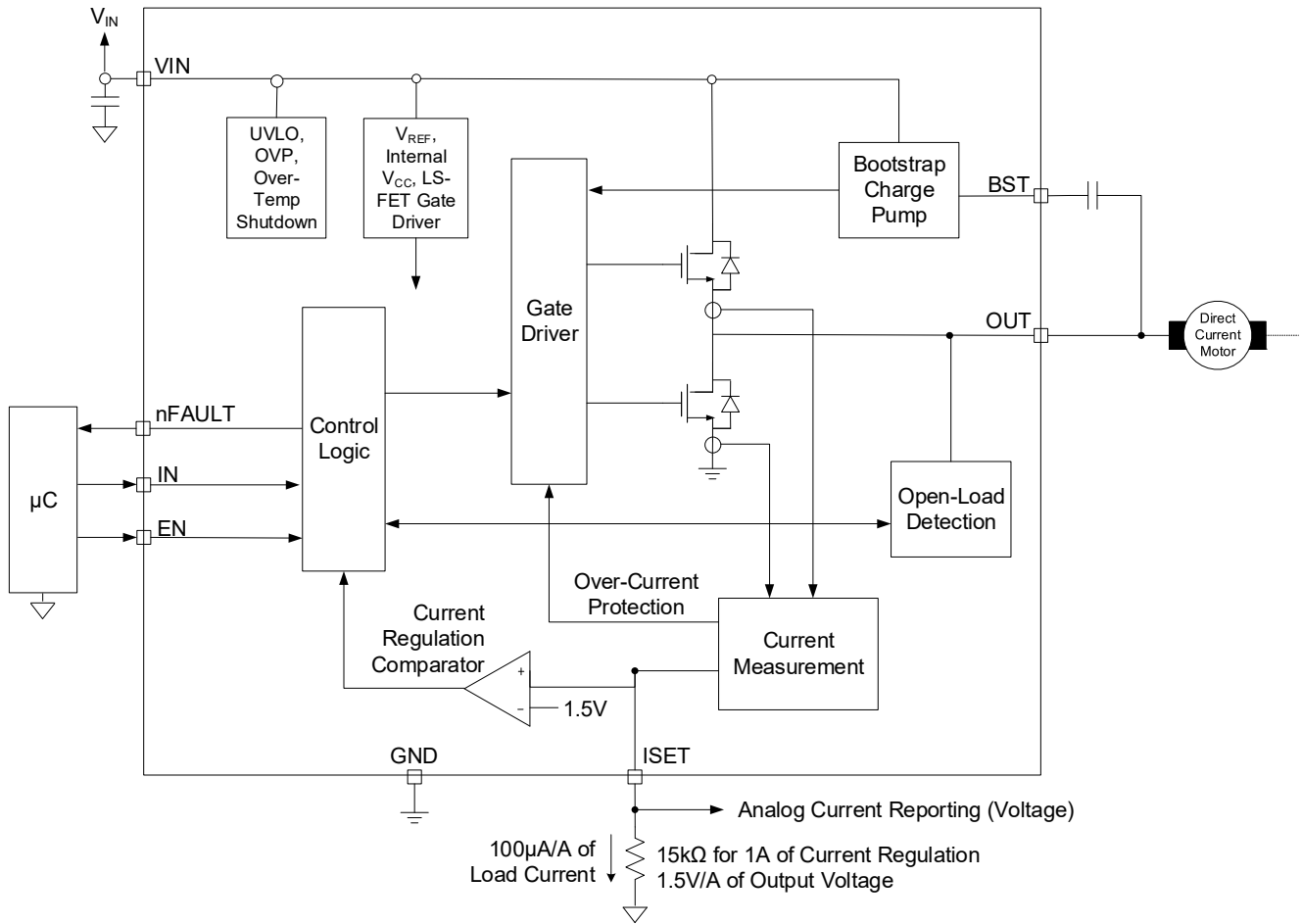
FUNCTIONAL BLOCK DIAGRAM

Figure 1: Functional Block Diagram

OPERATION

The MP6610 is a half-bridge driver that integrates two N-channel power MOSFETs. It can deliver up to 3A of output current across a wide 4V to 55V input voltage range. The MP6610 is designed to drive brushed DC motors, solenoids, and other loads.

Current Sense (CS)

The current-sense circuit senses the current flowing through the high-side MOSFET (HS-FET) or low-side MOSFET (LS-FET). A voltage proportional to the output current (I_{OUT}) is sourced from the ISET pin.

A resistor connected between ISET and ground sets the ISET pin voltage scaling. For each 1A of I_{OUT} , 100 μ A of current is sourced into the resistor connected to ISET. For example, if a 10k Ω resistor is connected between ISET and ground, ISET's output voltage is 1V/A of I_{OUT} .

If either the HS-FET or LS-FET is on, the current-sense circuit senses the current flowing through the MOSFET.

Current Limiting and Regulation

Constant-off-time (COT) pulse-width modulation (PWM) control circuitry limits I_{OUT} . The MP6610's current regulation function follows the steps below (see Figure 2):

1. Either MOSFET turns on and drives current through the load.
2. The current increases in the load, which is then sensed by the internal current-sense circuit.

3. If the load current exceeds the current trip voltage threshold (V_{TRIP}), the output state changes. For example, if the output is driving high, then it goes low; if the output is driving low, then it goes high.
4. If after a fixed off time (t_{OFF}) the load current drops to 80% of the current limit threshold, then the MOSFET turns on again and the cycle repeats.
5. If the current remains above 80%, then t_{OFF} is extended until the current drops to 80% of the current limit threshold.

A current trip occurs if the ISET voltage (V_{ISET}) reaches the current trip voltage threshold. For example, if a 10k Ω resistor is connected from ISET to ground, then the ISET voltage (V_{ISET}) is 1V/A of I_{OUT} . Therefore if the current reaches 1.5A, V_{ISET} reaches 1.5V, triggering a current trip.

Blanking Time

There is often a current spike while the HS-FET or LS-FET turns on. This can be caused by the body diode's reverse recovery current or the load's shunt capacitance. The current spike requires filtering to prevent the MOSFET from shutting down. If either the HS-FET or LS-FET turns on, then an internal fixed blanking time (t_{BLANK}) blanks the current-sense comparator. This blanking time also sets the minimum time that the output remains high or low after the input changes.

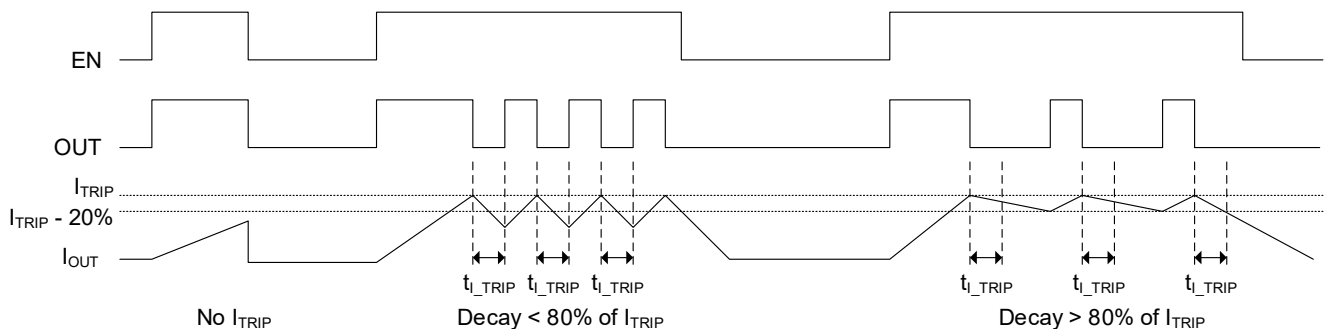

Figure 2: Current Regulation

Charge Pump and Bootstrap (BST) Charging

A bootstrap capacitor (C_{BST}) used in conjunction with an internal trickle charge pump generates the high-side (HS) gate driver voltage for the internal N-channel HS-FET. C_{BST} provides the high peak current required to switch the HS-FET quickly. The internal trickle charge pump keeps C_{BST} charged during long periods when the output is not switching.

Input Logic

Each MOSFET in the MP6610 is controlled independently using the IN and EN pins (see Table 1).

Table 1: Input Logic

EN	IN	Output
0	0	Hi-Z
0	1	Hi-Z
1	0	Low
1	1	High

The input pins are designed such that they can be driven with a logic level voltage even if the device's main power is inactive.

Protection and Diagnostic Functions

The MP6610 has an nFAULT pin that is pulled active low if any of the following fault protections are triggered: over-current protection (OCP), over-temperature protection (OTP), or open-load detection (OLD). nFAULT is not pulled low if a current limit trip occurs. nFAULT is an open-drain output that requires an external pull-up resistor. Once the fault condition is removed, nFAULT is pulled inactive high by the pull-up resistor.

Over-Current Protection (OCP)

If the current through either MOSFET exceeds the OCP threshold for longer than the over-current (OC) deglitch time, then an OC fault is triggered.

If an OC fault occurs, then the output state reverses until the current reaches 0A. Both the HS-FET and LS-FET turn off, and nFAULT is pulled low. The driver remains off for about 1.6ms, then turns on again and resumes normal operation.

OC faults are sensed on both the HS-FET and LS-FET. OC faults include shorts to ground, shorts to supply, and shorts across the motor winding. All OC fault can trigger an OC shutdown. Note that OCP does not use the same current-sense circuitry that PWM current control does. This means OCP is independent of the ISET resistance.

Open-Load Detection (OLD)

If the output is in a high-impedance state ($EN = 0V$), the internal circuits pull the OUT pin to half of the V_{IN} pin's voltage (V_{IN}) via a weak current. If a load is connected between OUT and ground, then the load pulls OUT close to ground. If a load is connected to V_{IN} , then OUT is pulled close to V_{IN} .

If OUT's voltage (V_{OUT}) is almost half of V_{IN} , then an open-load condition occurs and nFAULT is pulled active low. The fault is cleared once EN returns to active.

Input Under-Voltage Lockout (UVLO) Protection

If V_{IN} drops below the under-voltage lockout (UVLO) threshold, the device shuts down and the internal logic is reset. Once V_{IN} exceeds the UVLO threshold, the MP6610 starts up again and resumes normal operation.

Over-Voltage Protection (OVP)

If V_{IN} exceeds the over-voltage protection (OVP) threshold, the device shuts down. Once V_{IN} drops below the OVP threshold, the MP6610 starts up again and resumes normal operation.

Thermal Shutdown

If the die temperature exceeds its safe limits, all MOSFETs in the half-bridge shut down and the nFAULT pin goes low. Once the die temperature drops to a safe level, the MP6610 starts up again and resumes normal operation.

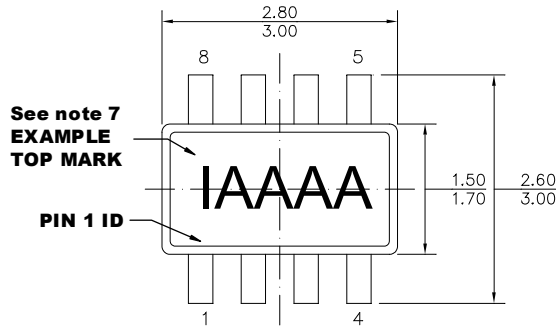
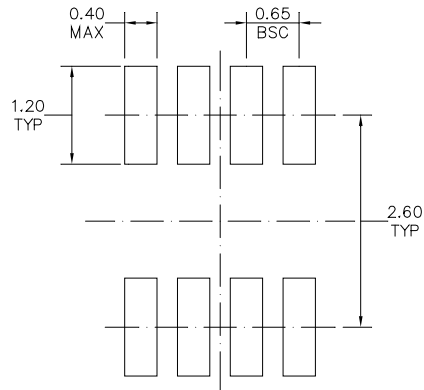
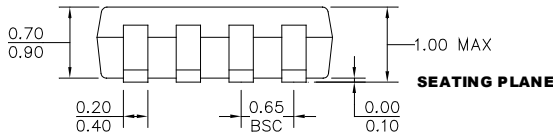
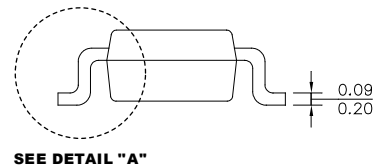
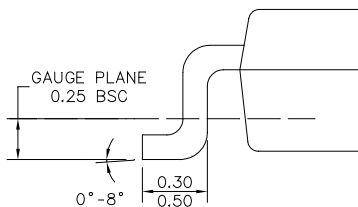
PACKAGE INFORMATION
TSOT23-8

TOP VIEW

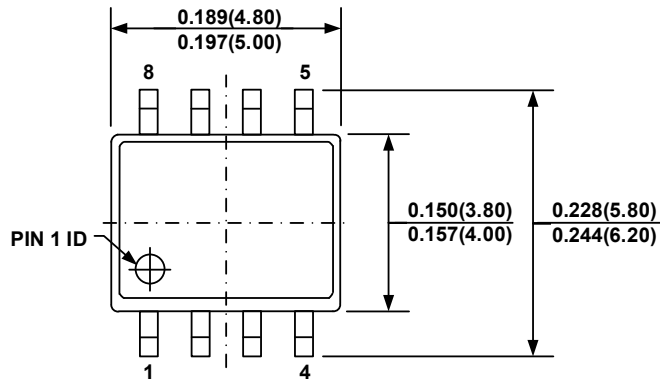
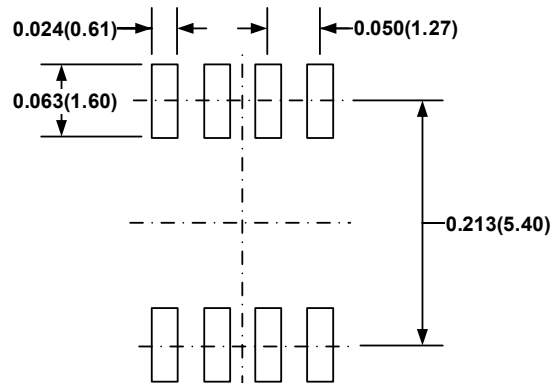
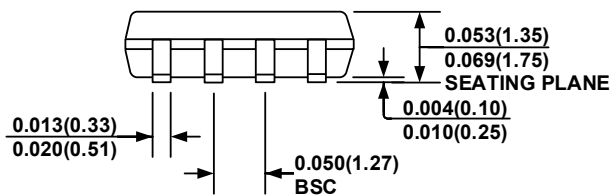
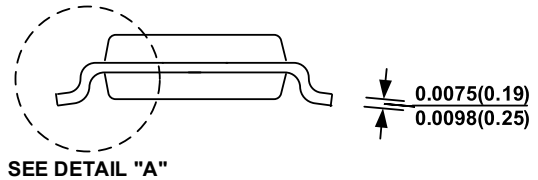
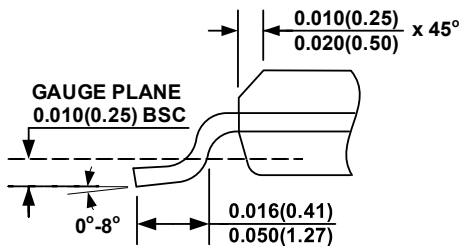
RECOMMENDED LAND PATTERN

FRONT VIEW

SIDE VIEW

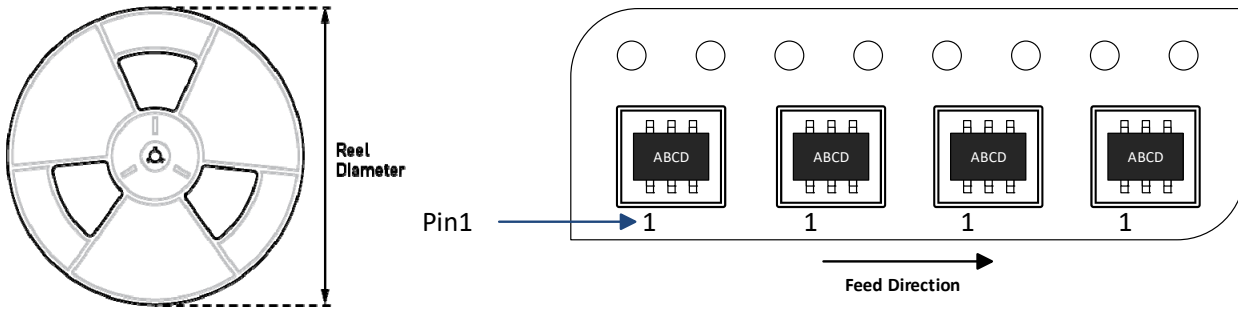
DETAIL "A"
NOTE:

- 1) ALL DIMENSIONS ARE IN MILLIMETERS.
- 2) PACKAGE LENGTH DOES NOT INCLUDE MOLD FLASH, PROTRUSIONS, OR GATE BURR.
- 3) PACKAGE WIDTH DOES NOT INCLUDE INTERLEAD FLASH OR PROTRUSIONS.
- 4) LEAD COPLANARITY (BOTTOM OF LEADS AFTER FORMING) SHALL BE 0.1 MILLIMETERS MAXIMUM.
- 5) JEDEC REFERENCE IS MO-193, VARIATION BA.
- 6) DRAWING IS NOT TO SCALE.
- 7) WHEN READING THE TOP MARKING FROM LEFT TO RIGHT, PIN 1 IS THE LOWER LEFT PIN (SEE EXAMPLE TOP MARKING).

PACKAGE INFORMATION
SOIC-8

TOP VIEW

RECOMMENDED LAND PATTERN

FRONT VIEW

SIDE VIEW

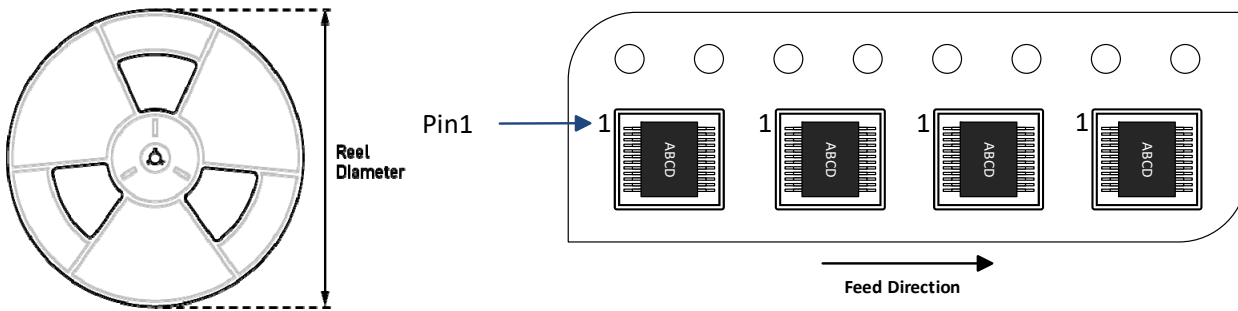
DETAIL "A"
NOTE:

- 1) CONTROL DIMENSIONS ARE IN INCHES. DIMENSIONS IN PARENTHESES ARE IN MILLIMETERS.
- 2) PACKAGE LENGTH DOES NOT INCLUDE MOLD FLASH, PROTRUSIONS, OR GATE BURR.
- 3) PACKAGE WIDTH DOES NOT INCLUDE INTERLEAD FLASH OR PROTRUSIONS.
- 4) LEAD COPLANARITY (BOTTOM OF LEADS AFTER FORMING) SHALL BE 0.004 INCHES MAXIMUM.
- 5) JEDEC REFERENCE IS MO-012, VARIATION AA.
- 6) DRAWING IS NOT TO SCALE.

CARRIER INFORMATION



Part Number	Package Description	Quantity/ Reel	Quantity/ Tube	Quantity/ Tray	Reel Diameter	Carrier Tape Width	Carrier Tape Pitch
MP6610GJ-Z	TSOT23-8	3000	N/A	N/A	7in	8mm	4mm



Part Number	Package Description	Quantity/ Reel	Quantity/ Tube	Quantity/ Tray	Reel Diameter	Carrier Tape Width	Carrier Tape Pitch
MP6610GS-Z	SOIC-8	2500	100	N/A	13in	12mm	8mm

REVISION HISTORY

Revision #	Revision Date	Description	Pages Updated
1.0	4/14/2021	Initial Release	-

Notice: The information in this document is subject to change without notice. Please contact MPS for current specifications. Users should warrant and guarantee that third-party Intellectual Property rights are not infringed upon when integrating MPS products into any application. MPS will not assume any legal responsibility for any said applications.