

Mar.1.2024 Copyright 2024 HIROSE ELECTRIC CO., LTD. All Rights Reserved.  
In case of consideration for using Automotive equipment / device which demand high reliability, kindly contact our sales window correspondents.

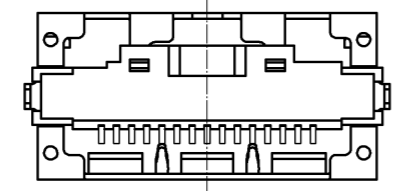

MATING FIGURE

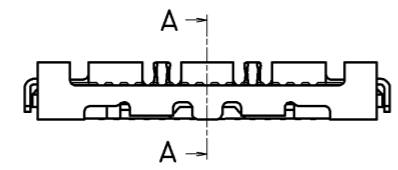
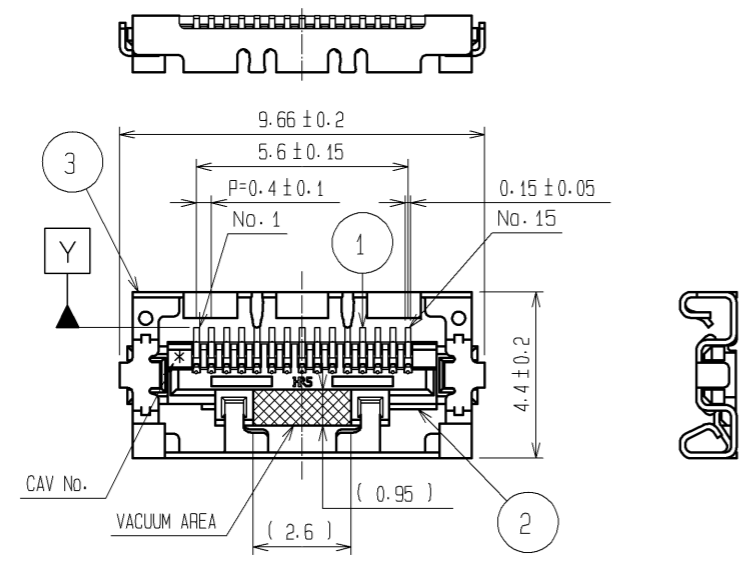
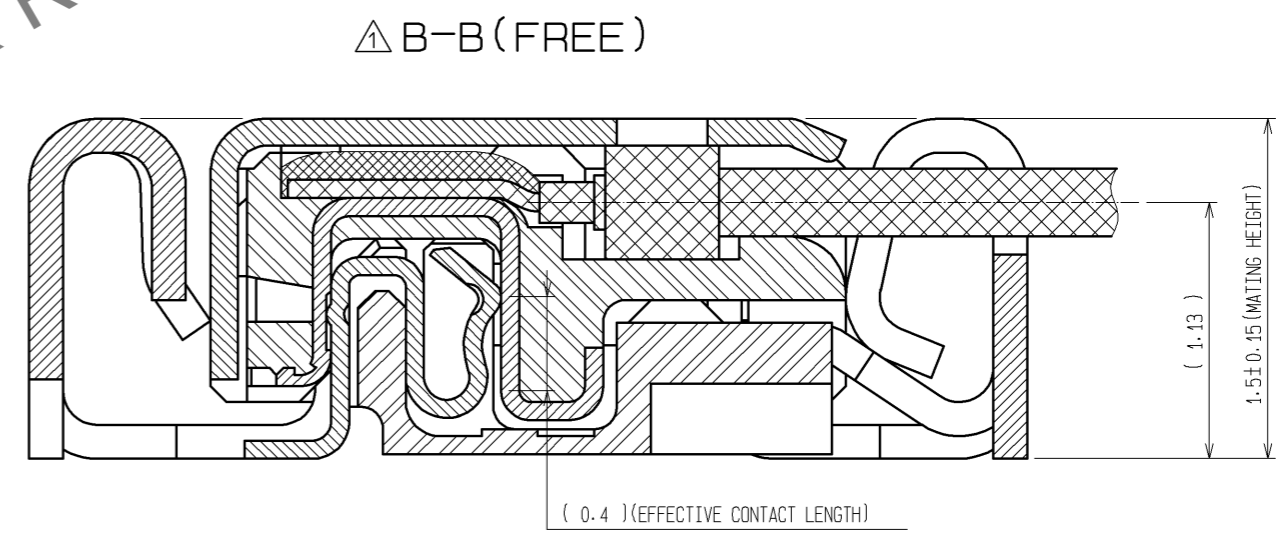
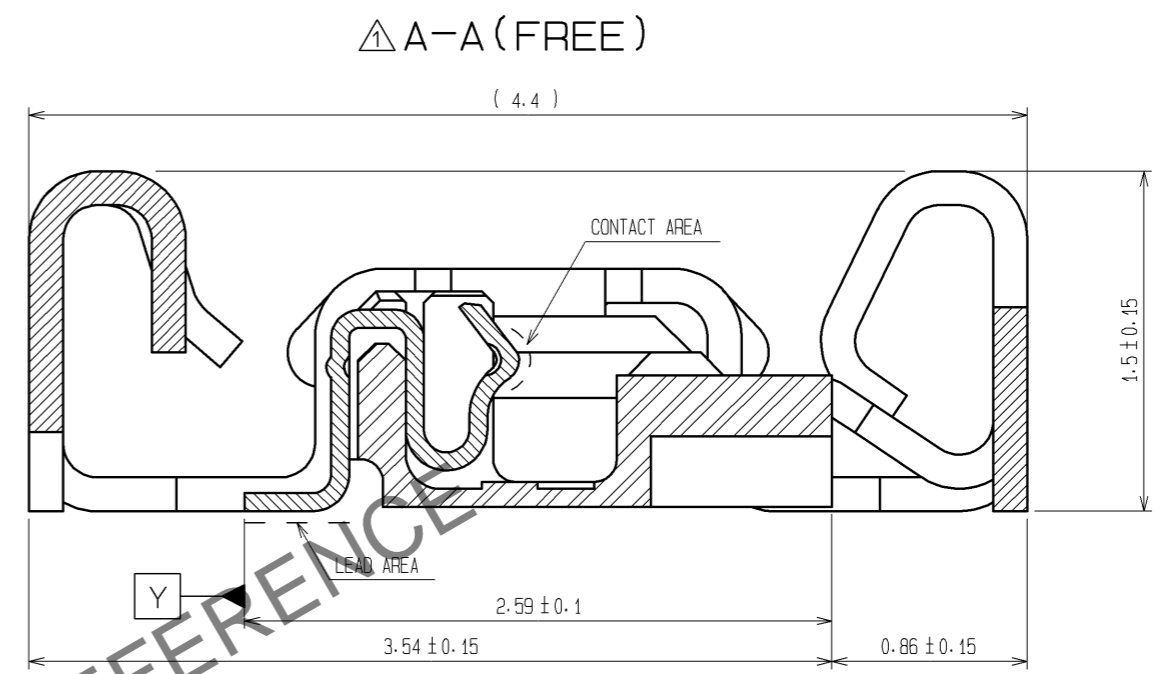
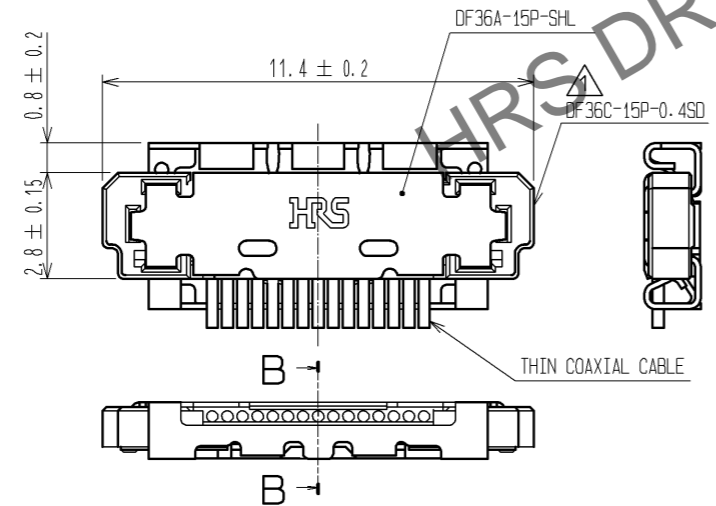

NOTES

1. LEAD CO-PLANARITY SHALL BE 0.1mm MAX.
2. STIFFENER IS REQUIRED FOR MOUNTING ONTO FPC IN ORDER TO AVOID STRESS BY FPC SLACKING TO MOUNTED CONNECTOR.
3. UNMATING SHALL BE DONE WITH THE SPECIFIC EXTRACTION TOOL.
4. SOLDERING REWORK IS NOT POSSIBLE SINCE SOLDERING LEADS ARE COVERED BY METAL SHIELDING.

2	LCP	UL94V-0	6	PS	BLACK		
1	PHOSPHOR BRONZE	CONTACT AREA : Au PLATING 0.3µm min LEAD AREA : Au PLATING 0.1µm min UNDER PLATING : Ni PLATING 2µm min	5	POLYESTER	CLEAR		
			4	PS	CLEAR		
			3	PHOSPHOR BRONZE	WHOLE AREA : Sn PLATING 1µm min UNDER PLATING : Cu PLATING 0.2µm min		
NO.	MATERIAL	FINISH . REMARKS	NO.	MATERIAL	FINISH . REMARKS		
UNITS mm		SCALE 5 : 1	COUNT 3	DESCRIPTION OF REVISIONS DIS-H-003523	DESIGNED SI. ISHII	CHECKED HK. UMEHARA	DATE 08.11.29
<b>HRS</b> HIROSE ELECTRIC CO., LTD.		APPROVED : TS. SAKATA 08.05.12	DRAWING NO. EDC3-317911-01				
		CHECED : HK. UMEHARA 08.05.10	PART NO. DF36A-15S-0.4V(51)				
		DESIGNED : HY. SHIOZAWA 08.05.09	CODE NO. CL662-4509-5-51				
		DRAWN : SI. ISHII 08.05.09					

Mar.1.2024 Copyright 2024 HIROSE ELECTRIC CO., LTD. All Rights Reserved.  
 In case of consideration for using Automotive equipment / device which demand high reliability, kindly contact our sales window correspondents.

