

1. DESCRIPTION

The XL1403 and XD1403 are precision band-gap voltage reference designed for critical instrumentation and D/A converter applications. This unit is designed to work with D/A converters, up to 12 bits in accuracy, or as a reference for power supply applications.

2. FEATURES

- Output Voltage: 2.5 V \pm 25 mV
- Input Voltage Range: 4.5 V to 30 V
- Quiescent Current: 1.2 mA Typical
- Output Current Up to 10mA
- Temperature Coefficient: 10 ppm/ $^{\circ}$ C Typical
- Guaranteed Temperature Drift Specification
- Function Equivalent to AD580
- Standard 8-Pin DIP (XD1403), and 8-Pin SOIC (XL1403) Package

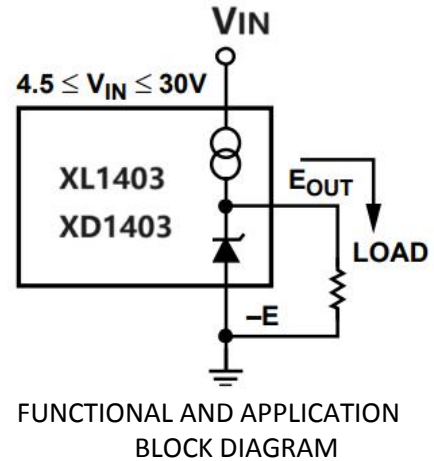

3. APPLICATIONS

- Voltage Reference for 8 to 12 Bit D/A Converters
- Low TC Zener Replacement
- High Stability Current Reference
- Voltmeter System Reference
- Pb-Free Package is Available

4. PIN CONNECTIONS

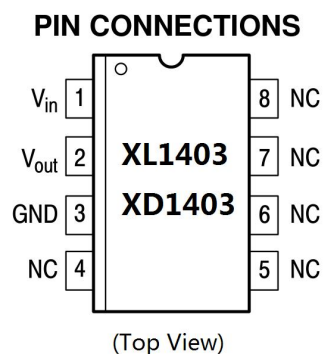

5. MAXIMUM RATINGS

Rating	Symbol	Value	Unit
Input Voltage	V_I	40	V
Storage Temperature	T_{stg}	-50 to 150	°C
Junction Temperature	T_J	+150	°C
Operating Ambient Temperature Range XL/XD1403	T_A	-40 to + 80	°C

Maximum ratings are those values beyond which device damage can occur. Maximum ratings applied to the device are individual stress limit values (not normal operating conditions) and are not valid simultaneously. If these limits are exceeded, device functional operation is not implied, damage may occur and reliability may be affected.

6. ELECTRICAL CHARACTERISTICS ($V_{in} = 15\text{ V}$, $T_A = 25^\circ\text{ C}$, unless otherwise noted.)

Characteristic	Symbol	Min	Typ	Max	Unit
Output Voltage ($I_O = 0\text{ mA}$)	V_{out}	2.475	2.5	2.525	V
Temperature Coefficient of Output Voltage*	$\Delta V_O/\Delta T$	-		40	ppm/°C
Output Voltage Change* (Over specified temperature range) XL/XD1403 -40 to +80°C	ΔV_O	-	-	7.0	mV
Line Regulation ($I_O = 0\text{ mA}$) ($15\text{ V} \leq V_I \leq 40\text{ V}$) ($4.5\text{ V} \leq V_I \leq 15\text{ V}$)	Regline	-	1.2 0.6	4.5 3.0	mV
Load Regulation ($0\text{ mA} < I_O < 10\text{ mA}$)	Regload	-	-	10	mV
Quiescent Current ($I_O = 0\text{ mA}$)	I_Q	-	1.2	2.0	mA

*Guaranteed but not tested

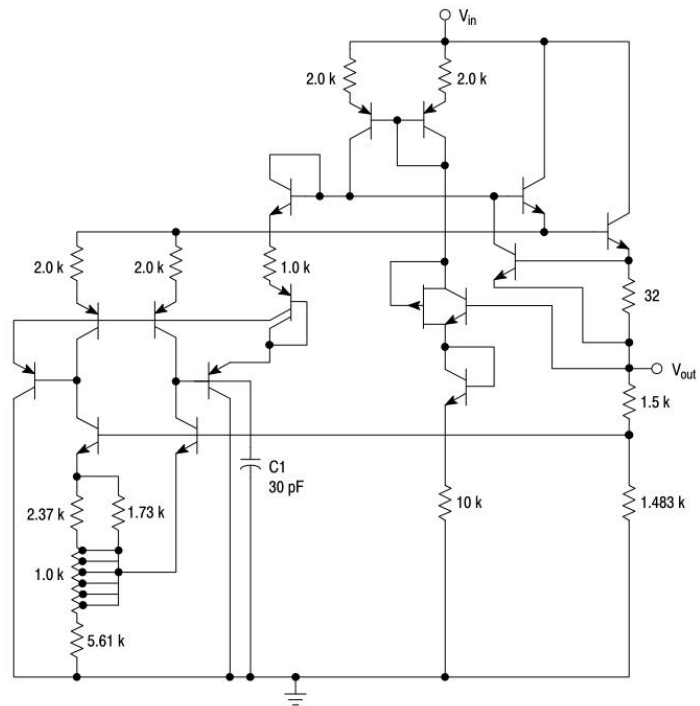

Figure 2. Inner Schematic Diagram for XL/XD1403

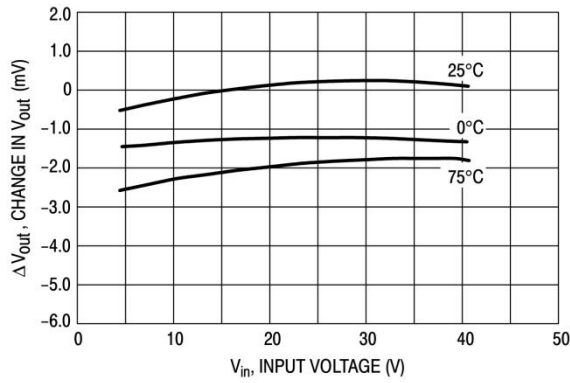

Figure 3. Typical Change in Vout versus Vin
(Normalized to Vin = 15 V @ TC = 25°C)

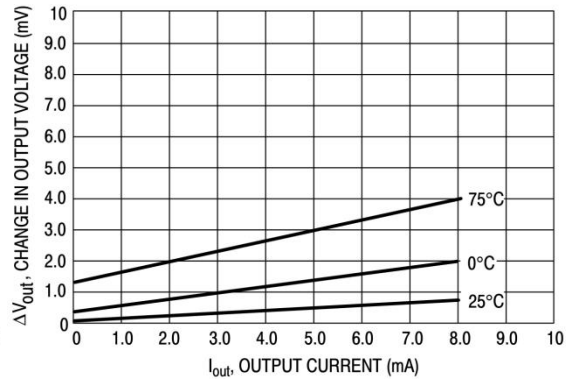

Figure 4. Change in Output Voltage versus Load Current
(Normalized to Vout @ Vin = 15 V, Iout = 0 mA)

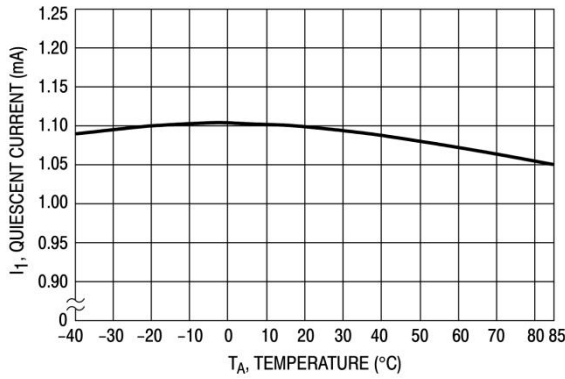

Figure 5. Quiescent Current versus Temperature
(Vin = 15 V, Iout = 0 mA)

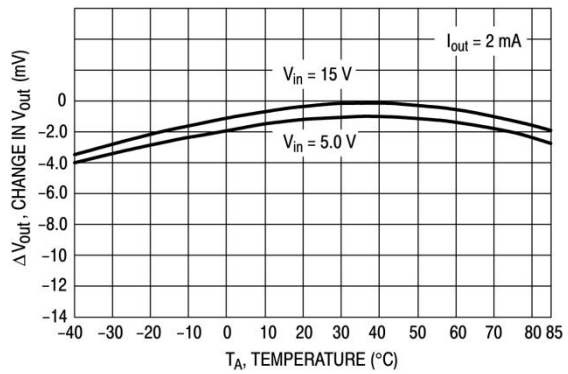

Figure 6. Change in Vout versus Temperature
(Normalized to Vout @ Vin = 15 V)

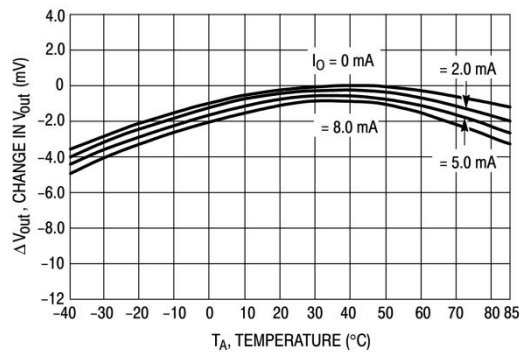

Figure 7. Change in Vout versus Temperature
(Normalized to TA = 25°C, Vin = 15 V, Iout = 0 mA)

7. APPLICATION EXAMPLE

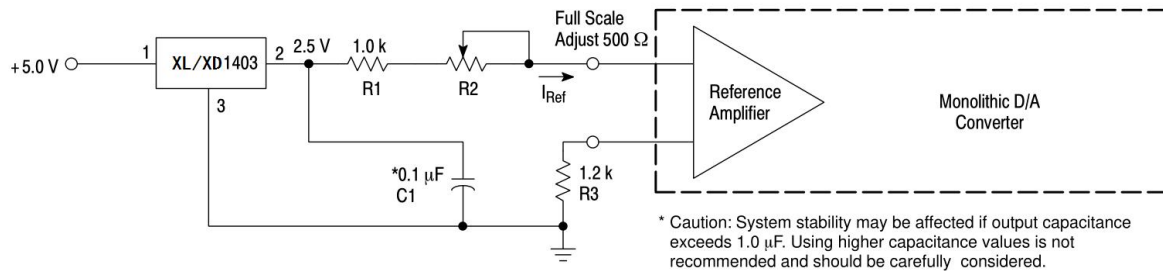

Figure 1.A Reference for Monolithic D/A Converters

The XL/XD1403 makes an ideal reference for many mono-lithic D/A converters, requiring a stable current reference of nominally 2.0 mA. This can be easily obtained from the XL/XD1403 with the addition of a series resistor, R1. A variable resistor, R2, is recommended to provide means for full-scale adjust on the D/A converter.

The resistor R3 improves temperature performance by matching the impedance on both inputs of the D/A reference amplifier. The capacitor decouples any noise present on the reference line. It is essential if the D/A converter is located any appreciable distance from the reference. A single XL/XD1403 reference can provide the required current input for up to five of the monolithic D/A converters.

8. ORDERING INFORMATION

Ordering Information

Part Number	Device Marking	Package Type	Body size (mm)	Temperature (°C)	MSL	Transport Media	Package Quantity
XL1403	XL1403	SOP8	4.90 * 3.90	- 40 to 85	MSL3	T&R	2500
XD1403	XD1403	DIP8	9.25 * 6.38	- 40 to 85	MSL3	Tube 50	2000

9. DIMENSIONAL DRAWINGS

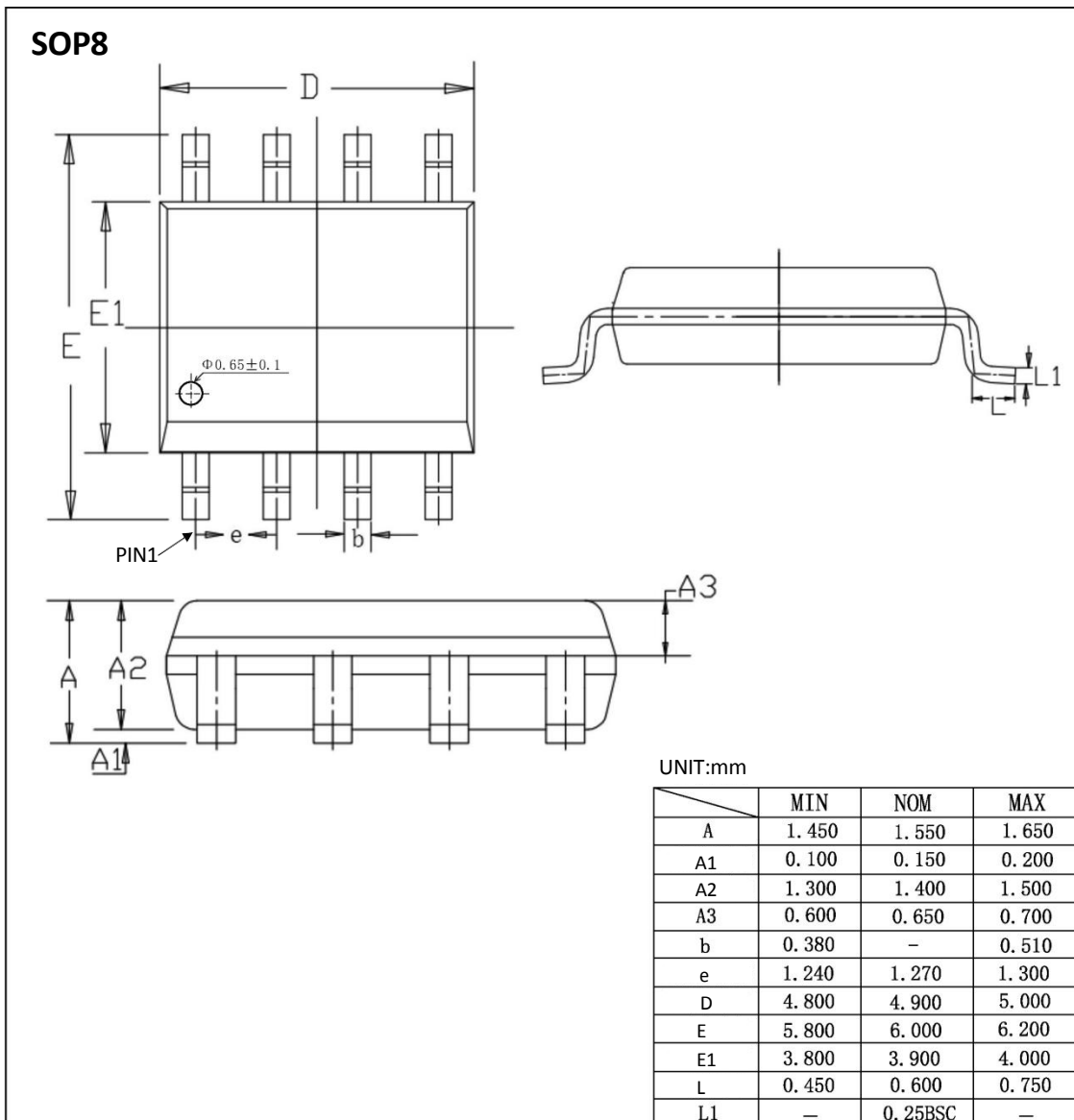

DIP8

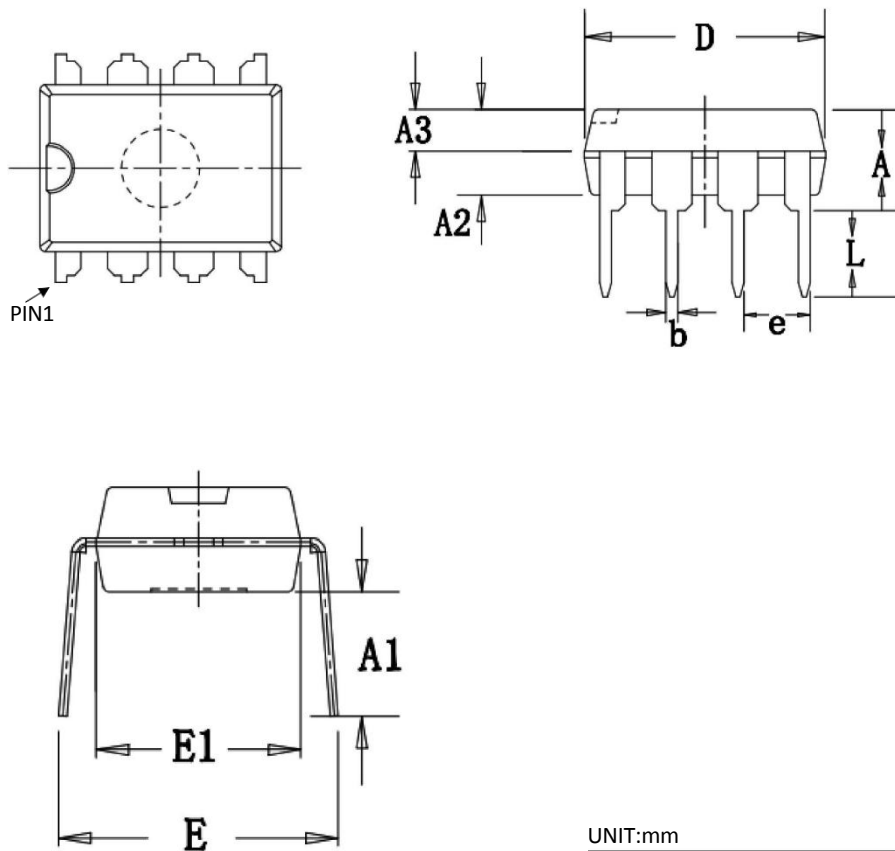

UNIT:mm

	MIN	NOM	MAX
A	3.600	3.800	4.000
A1	3.786	3.886	3.986
A2	3.200	3.300	3.400
A3	1.550	1.600	1.650
b	0.440	—	0.490
e	2.510	2.540	2.570
D	9.150	9.250	9.350
E	7.800	8.500	9.200
E1	6.280	6.380	6.480
L	3.000	—	—

[if you need help contact us. Xinluda reserves the right to change the above information without prior notice]