



LTEM NO.: MC-313G (Consumer Electronics)

(9.85L×9.64W×3.16H & DUL SMT LOW PCB TYPE)

Type-C Universal Serial Bus Connectors



Technical parameter

外焊 SMT+DIP

PROJECT	LEVEL	A[better product]	B[average product]
		Contact Rating	
Electrical Properties	Initial Contact Resistance	30mΩ max.	50mΩ max.
	Insulation Resistance	100MΩ min.500V DC	Skey/PD: 100MΩ min.300V DC
	Withstand Voltage	500V AC for 1 minute	350 V AC for 1 minut
Durable Performance	There No Load	6,500 Cycles	5,500 Cycles
	Rated Load	5,500 Cycles	4,500 Cycles
Storage temp.		-25℃~+75℃(Operating Temp:)	

側向導入 LATERAL

精密部品 NICETY

可靠 STABILIZE

環保材質 RoHS

Page1

Unit:mm

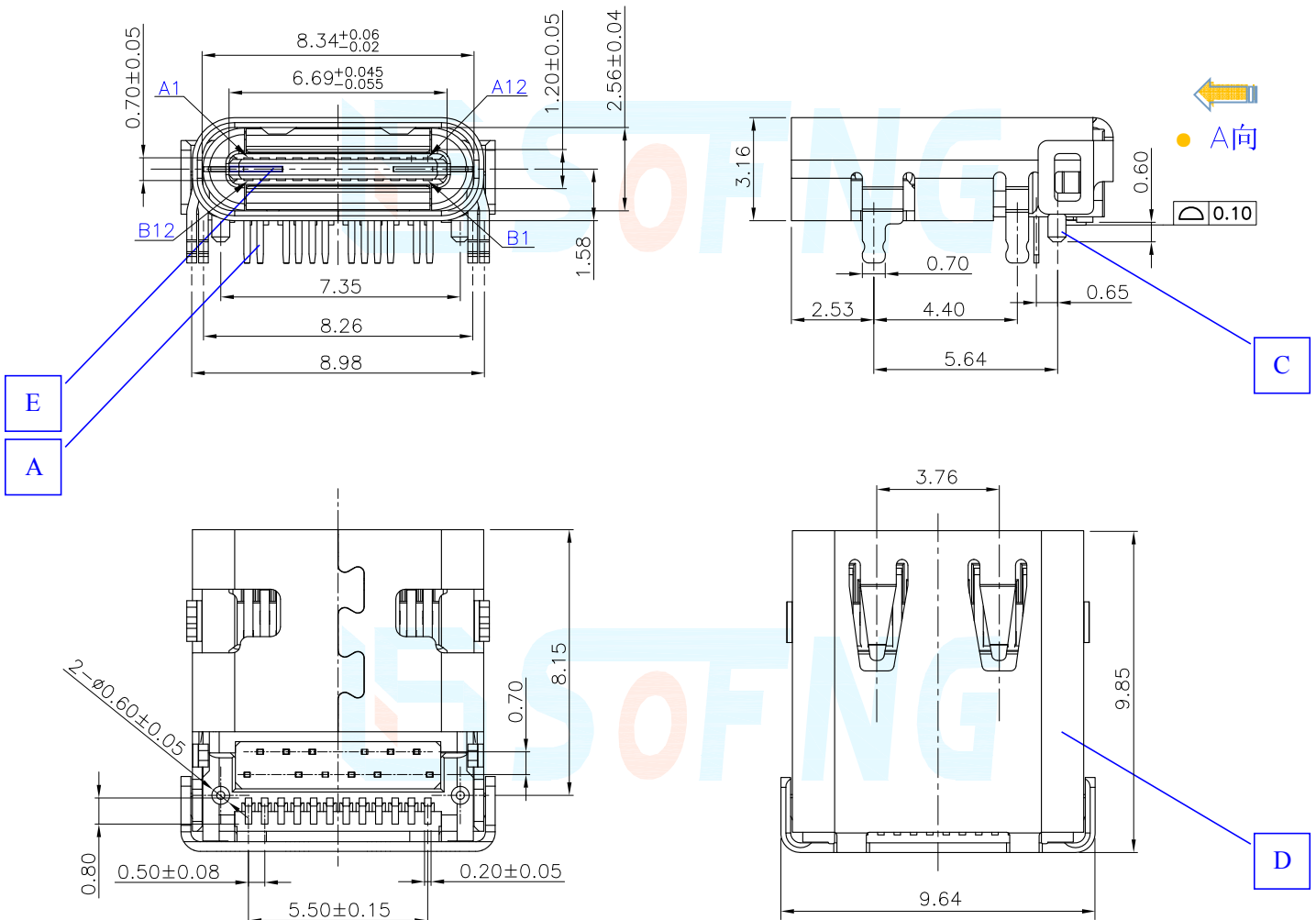
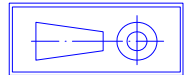

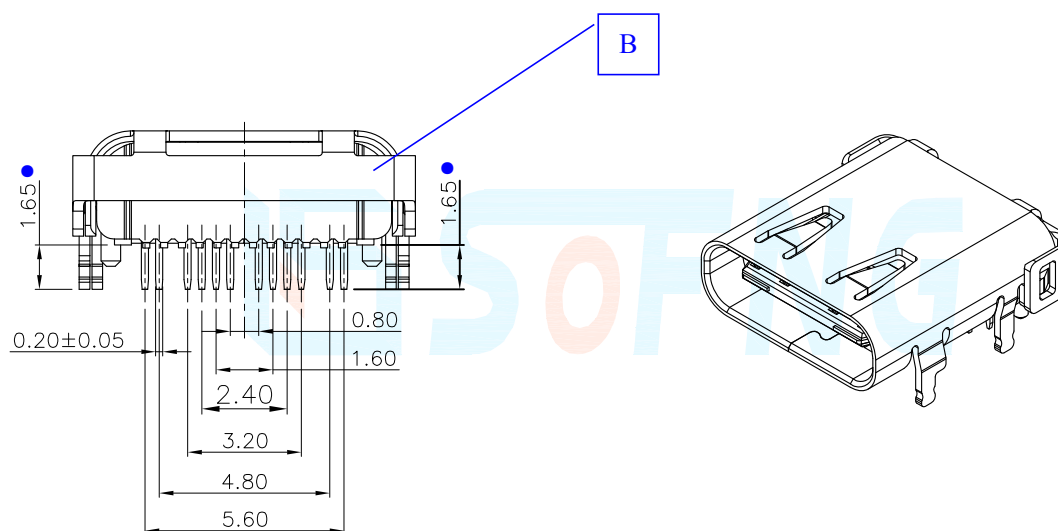

● A向示意图

SPECIFIED TOLERANCES

UNLESS OTHERWISE



DECIMALS	ANGLES
X.X :±0.25	X.X :±3°
X.XX :±0.15	X.XX :±2°
X.XXX :±0.10	

Material declaration			
No.	NAME	MATERIAL	DESCRIPTION
① A	TERMINAL 接触端子	COPPER ALLOY 【G/F】	2.0 μ m Ni PLATED OVERALL; 0.25 μ m Au PLATED CONTACT AREA; GOLD FLASH ON SOLDER AREA.
② B	SHIELDING PLATE 屏蔽壳	STAINLESS 【G/F】	0.25 μ m Ni PLATED OVERALL;
③ C	CASE	THERMOPLASTIC	UL 94V-0,COLOR:BLACK;
④ D	SHELL	STAINLESS 【G/F】	0.25 μ m Ni PLATED OVERALL;
⑤ E	GUARD PLATE	STAINLESS 【G/F】	STAINLESS STEEL(t=0.10mm)



MATERIAL

Operating Force

Inward
Exiting

6.0~10.0N. (1N.=100gram-force)
8.0~12.0N. (1N.=100gram-force)

Solder-ability (Max.)

IR Reflow:255°C, 5sec. Manual :350°C, 3sec.

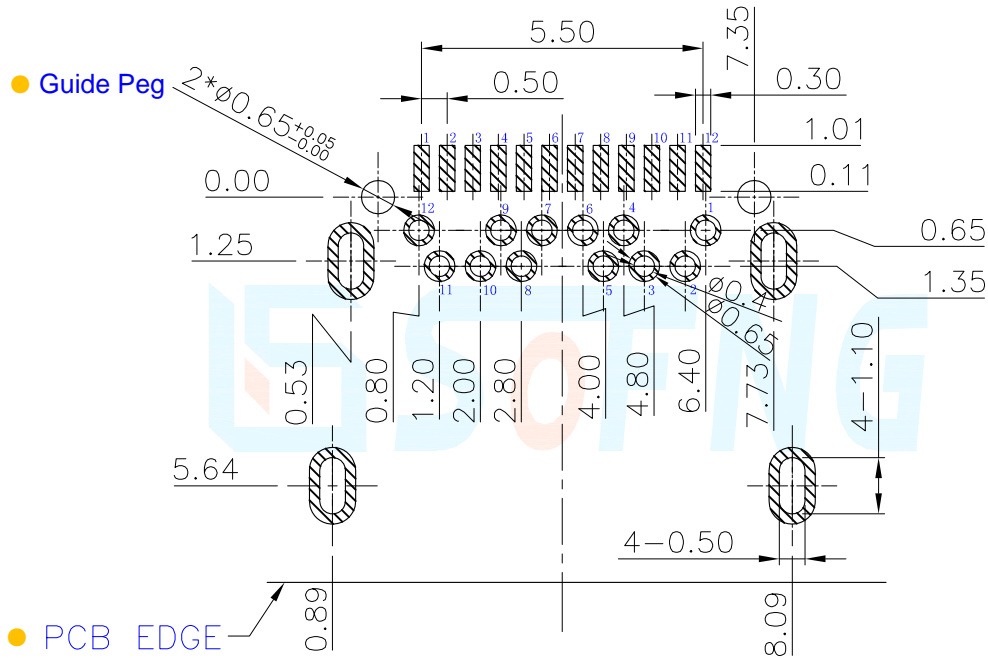

PIN ASSIGNMENTS

PIN	Signal NAME	Description	PIN	Signal NAME	Description
A 1	GND	Ground return	B12	GND	Ground return
A 2	SSTXp1	Positive half of first SuperSpeed TX differential pair	B11	SSRXp1	Positive half of second SuperSpeed RX differential pair
A 3	SSTXn1	Negative half of first SuperSpeed TX differential pair	B10	SSRXn1	Negative half of second SuperSpeed RX differential pair
A 4	V BUS	Bus Power	B 9	V BUS	Bus Power
A 5	CC1	Configuration Channel	B 8	SBU2	Sideband Use (SBU)
A 6	Dp1	Positive half of the USB 2.0 differential pair-Position 1	B 7	Dn2	Negative half of the USB 2.0 differential pair-Position 2
A 7	Dn1	Negative half of the USB 2.0 differential pair-Position 1	B 6	Dp2	Positive half of the USB 2.0 differential pair-Position 2
A 8	SBU1	Sideband Use (SBU)	B 5	CC2	Configuration Channel
A 9	V BUS	Bus Power	B 4	V BUS	Bus Power
A10	SSRXn2	Negative half of second SuperSpeed RX differential pair	B 3	SSTXn2	Negative half of first SuperSpeed TX differential pair2
A11	SSRXp2	Positive half of second SuperSpeed RX differential pair	B 2	SSTXp2	Positive half of first SuperSpeed TX differential pair2
A12	GND	Ground return	B 1	GND	Ground return

注記 NOTICE

1. 碩方公司擁有最終解釋權；The SOFNG company reserves the right of final interpretation；
2. 文件禁止外洩、轉載；Leaked and reproduced prohibited；
3. 未經授權修改無效。Modify is invalid.