

| P | LTR | DESCRIPTION | DATE | DWN | APVD |
|---|-----|-----------------------------------|-----------|-----|------|
| | 01 | REVISED PER ECO-12-007711 | 26APR2012 | KH | MS |
| | A | NEW PART NO. 5-1776155-3 IS ADDED | 22SEP2023 | SP | PS |
| | | | | | |

NOTES:

1. MATERIAL AND FINISH :
HOUSING : HIGH TEMPERATURE POLYAMIDE UL94 V0
HOUSING COLOR : BLACK
TERMINAL : COPPER ALLOY ,TIN PLATED OVER NICKEL UNDERPLATED.
2. ELECTRICAL PROPERTIES:
RATED VOLTAGE: 300V
RATED CURRENT: 15A
CONTACT RESISTANCE : <15 m Ohm
INSULATION RESISTANCE : >1000 M Ohm (500V DC)
3. NOT CUMULATIVE TOLERANCE
4. OPERATING TEMPERATURE RANGE : -40°C TO +105°C.
5. PACKAGING: BULK PACKING AS PER 107-160052
6. PACKAGING: T & R PACKING AS PER 107-160194

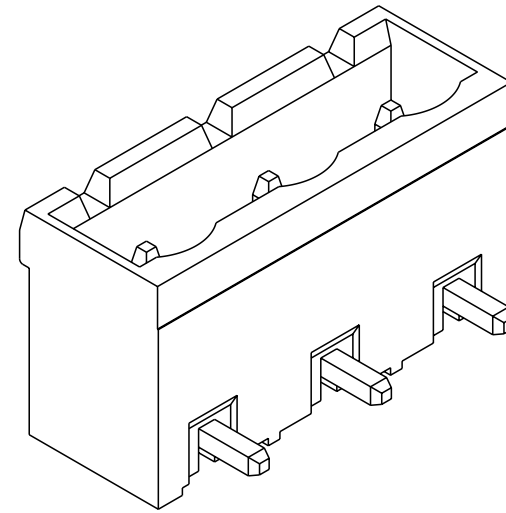

1776155-3 AS SHOWN

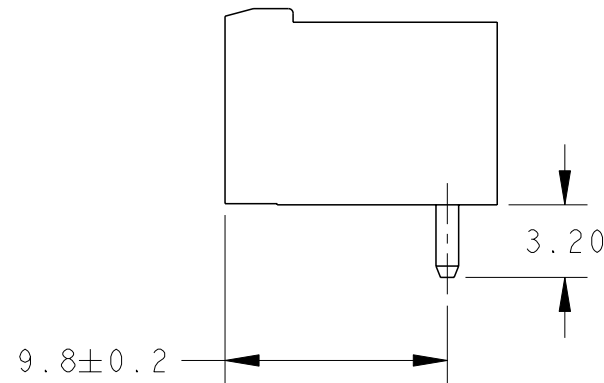
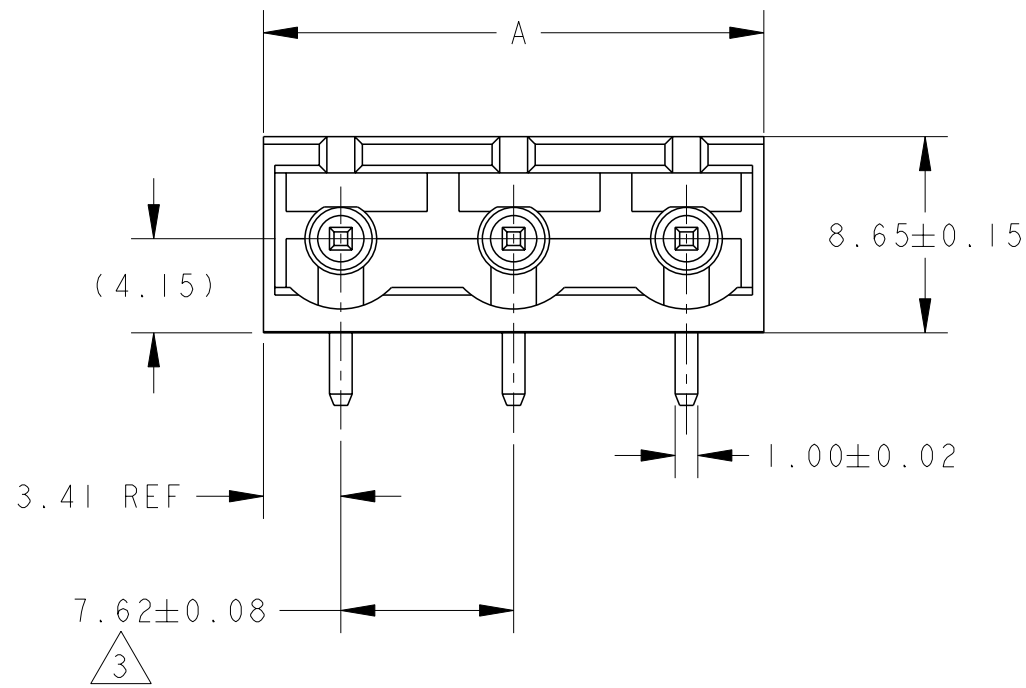
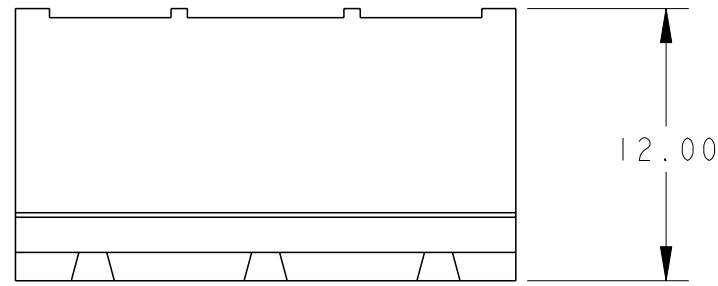

| | | | | |
|------------|---------------|-----------|------------|-------------|
| 44 | TAPE AND REEL | 22.06 | 3 | 5-1776155-3 |
| X | BULK | 90.64 | 12 | 1-1776155-2 |
| | | 83.02 | 11 | 1-1776155-1 |
| | | 75.40 | 10 | 1-1776155-0 |
| | | 67.78 | 9 | 1776155-9 |
| | | 60.16 | 8 | 1776155-8 |
| | | 52.54 | 7 | 1776155-7 |
| | | 44.92 | 6 | 1776155-6 |
| | | 37.30 | 5 | 1776155-5 |
| | | 29.68 | 4 | 1776155-4 |
| | | 22.06 | 3 | 1776155-3 |
| 14.44 | 2 | 1776155-2 | | |
| TAPE WIDTH | PACKAGING | A | NO OF POSN | PART NUMBER |

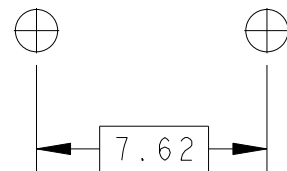
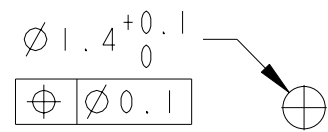

RECOMMENDED PC BOARD LAYOUT

| | | | | | |
|--|--|--------------------------|--|--------------------------------|--|
| THIS DRAWING IS A CONTROLLED DOCUMENT. | | DWN S.WELDON 11JUL2005 | | | |
| DIMENSIONS: mm | | CHK C.RICHARD 11JUL2005 | | | |
| TOLERANCES UNLESS OTHERWISE SPECIFIED: | | APVD C.RICHARD 11JUL2005 | | NAME | |
| 0 PLC ±- | | PRODUCT SPEC | | TERMINAL BLOCK, PLUG 90 DEGREE | |
| 1 PLC ±0.2 | | 108-161088 | | 7.62mm PITCH | |
| 2 PLC ±0.25 | | APPLICATION SPEC | | SIZE | |
| 3 PLC ±- | | 114-20079 | | CAGE CODE | |
| 4 PLC ±- | | WEIGHT | | DRAWING NO | |
| ANGLES ±° | | - | | A300779 | |
| MATERIAL | | FINISH | | RESTRICTED TO | |
| - | | - | | - | |
| - | | - | | SCALE 3:1 | |
| - | | - | | SHEET 1 OF 1 | |
| - | | - | | REV A | |