

5-Bit Programmable Output BiCMOS Precision Voltage Reference

FEATURES

- 5 - Bit Digital-to-Analog Converter (DAC) supports Intel Pentium II™ Microprocessor VID Codes
- Compatible with 5V Systems
- 1% Output Voltage Accuracy Guaranteed

DESCRIPTION

The UCC391 provides an accurate reference, programmable by a 5-bit DAC, in a tiny 8 pin package. Using few external components, the UCC391 converts 5V to an adjustable output ranging from 3.5VDC to 2.1VDC in 100mV steps and 2.05VDC to 1.3VDC in 50mV steps with 1% DC system accuracy.

This device is available in and 8 pin surface mount (150mm SOIC) and TSSOP packages and is specified for operation from 0°C to 70°C.

BLOCK DIAGRAM

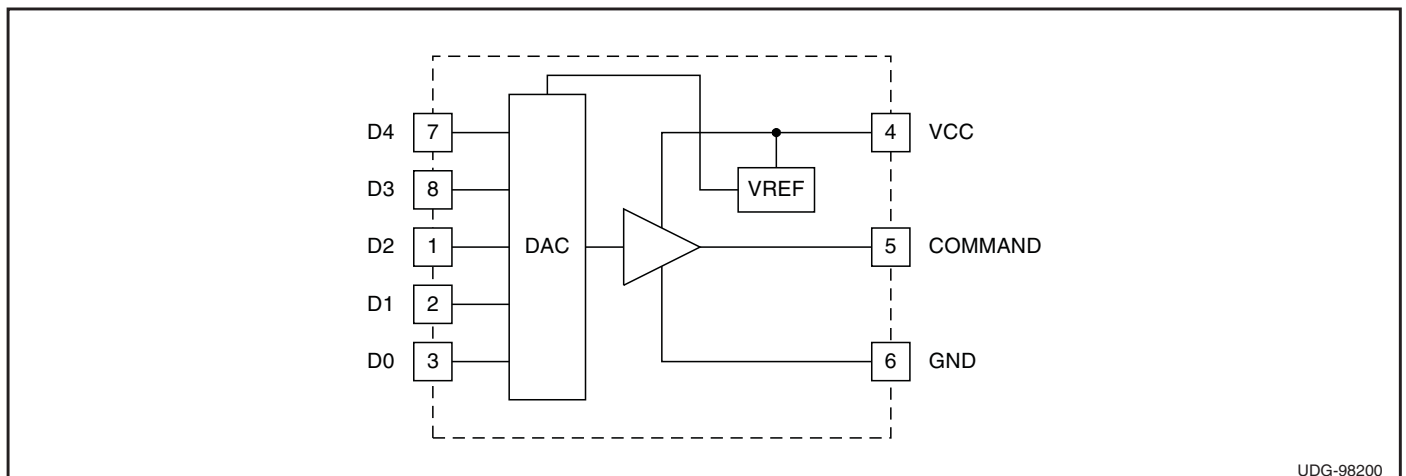

UDG-98200

ABSOLUTE MAXIMUM RATINGS

Supply Voltage V_{CC} 8V
 Input Voltage, D0, D1, D2, D3, D4 8V

Currents are positive into, negative out of the specified terminal. Consult Packaging Section of Databook for thermal limitations and considerations of packages. All voltages are referenced to GND.

CONNECTION DIAGRAMS

**MSOP-8, TSSOP-8 (TOP VIEW)
 P, PW Packages**

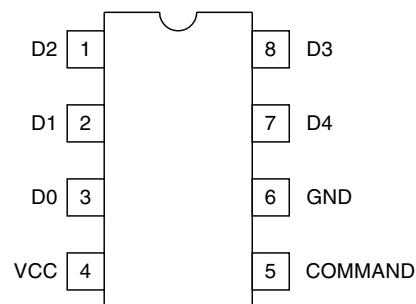

ELECTRICAL CHARACTERISTICS: Unless otherwise specified these specifications hold for $T_A = 0^\circ\text{C}$ to 70°C for the UCC391, $T_A = T_J$. $V_{CC} = 5\text{V}$.

PARAMETER	TEST CONDITIONS	MIN	TYP	MAX	UNITS
Supply Current Section					
Supply Current, On	$V_{CC} = 5\text{V}$		1.8		mA
DAC Reference Section					
COMMAND Voltage Accuracy	$4.5\text{V} < V_{IN} < 5.5\text{V}$, measured on COMMAND, $0^\circ\text{C} < T_A < 70^\circ\text{C}$ (Note 1)	-1.00		1.00	%
D0 – D4 Voltage High		4.5	5	5.5	V
D0 – D4 Voltage Threshold			2.5		V
D0 – D4 Input Bias Current	$V(\text{D4, D3, D2, D1, D0}) < 0.5\text{V}$		-90	-20	μA
Output Current (Maximum Load)	$I_{OUT}(V_{COMMAND})$	0		150	μA

Note 1: Reference and output amplifier offsets are trimmed out before packaging.

PIN DESCRIPTIONS

GND: (Ground) All voltages measured with respect to ground. VCC should be bypassed directly to GND with a $0.1\mu\text{F}$ or larger ceramic capacitor.

VCC: (Positive supply voltage) This pin is normally connected to a $5\text{V} \pm 10\%$ system voltage. Bypass VCC directly to GND with a $0.1\mu\text{F}$ (minimum) ceramic capacitor.

COMMAND: This pin is the output of the IC. It is controlled by the 5-bit input word (D0:D4). This output will have a $\pm 1\%$ system accuracy over temperature, process, and input voltage.

D0, D1, D2, D3, D4: These are the digital input control codes for the DAC. The DAC is comprised of two ranges set by D4, with D0 representing the least significant bit (LSB) and D3, the most significant bit (MSB). A bit is set low by being connected to GND; a bit is set high by floating the pin. Each control pin is pulled up to approximately 5V by an internal pull-up. If all ones are commanded on the DAC inputs (no CPU command), the output will be disabled.

APPLICATION INFORMATION

D4	D3	D2	D1	D0	V _{OUT}
0	1	1	1	1	1.3
0	1	1	1	0	1.35
0	1	1	0	1	1.4
0	1	1	0	0	1.45
0	1	0	1	1	1.5
0	1	0	1	0	1.55
0	1	0	0	1	1.6
0	1	0	0	0	1.65
0	0	1	1	1	1.7
0	0	1	1	0	1.75
0	0	1	0	1	1.8
0	0	1	0	0	1.85
0	0	0	1	1	1.9
0	0	0	1	0	1.95
0	0	0	0	1	2
0	0	0	0	0	2.05
1	1	1	1	1	NO OUTPUT
1	1	1	1	0	2.1
1	1	1	0	1	2.2
1	1	1	0	0	2.3
1	1	0	1	1	2.4
1	1	0	1	0	2.5
1	1	0	0	1	2.6
1	1	0	0	0	2.7
1	0	1	1	1	2.8
1	0	1	1	0	2.9
1	0	1	0	1	3
1	0	1	0	0	3.1
1	0	0	1	1	3.2
1	0	0	1	0	3.3
1	0	0	0	1	3.4
1	0	0	0	0	3.5

Table I. VID Codes and Resulting Regulator Output Voltage