

FEATURES

- Low Offset Voltage 150 μ V Max
- Low Offset Voltage Drift 2.5 μ V/ $^{\circ}$ C Max
- Load Current Capability 5mA Min
- Internal Frequency Compensation
- 125 $^{\circ}$ C Temperature Tested Die
- Low Offset Current 200pA Max
- Low Bias Current 2.0nA Max
- Low Power Consumption 18mW Max @ \pm 15V
- High Common-Mode Input Range \pm 13V Min
- MIL-STD-883 Class B Processing Available
- Silicon-Nitride Passivation
- Available in Die Form

ORDERING INFORMATION [†]

$T_A = +25^{\circ}\text{C}$ $V_{OS} \text{ MAX}$ (mV)	PACKAGE		OPERATING TEMPERATURE RANGE
	TO-99 8-PIN	CERDIP 8-PIN	
0.15	—	OP12AZ*	MIL
0.15	OP12EJ	OP12EZ	COM
0.30	OP12BJ	OP12BZ/883	MIL
0.30	OP12FJ	OP12FZ	COM
1.0	OP12GJ	—	COM

* For devices processed in total compliance to MIL-STD-883, add /883 after part number. Consult factory for 883 data sheet.

[†] Burn-in is available on commercial and industrial temperature range parts in CerDIP, plastic DIP, and TO-can packages.

GENERAL DESCRIPTION

The PMI OP-12 is an improved version of the popular LM108A low-power op amp. The OP-12 is internally compensated and its chip dimensions are only 42 X 58 mils. Offset voltage is lower; the total worst-case input offset voltage over -55°C to $+125^{\circ}\text{C}$ for the OP-12A is only 350 μ V. In addition, the OP-12 drives a 2k Ω load which is five times the output current capability of the 108A. This excellent performance is achieved by applying PMI's ion-implanted super-beta process and on-chip zener-zap trimming capabilities. The internal compensation makes this op amp ideal for hybrid assembly applications.

PIN CONNECTIONS

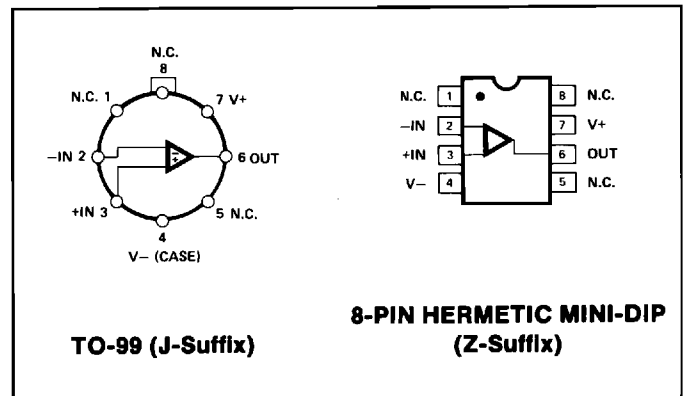

SIMPLIFIED SCHEMATIC

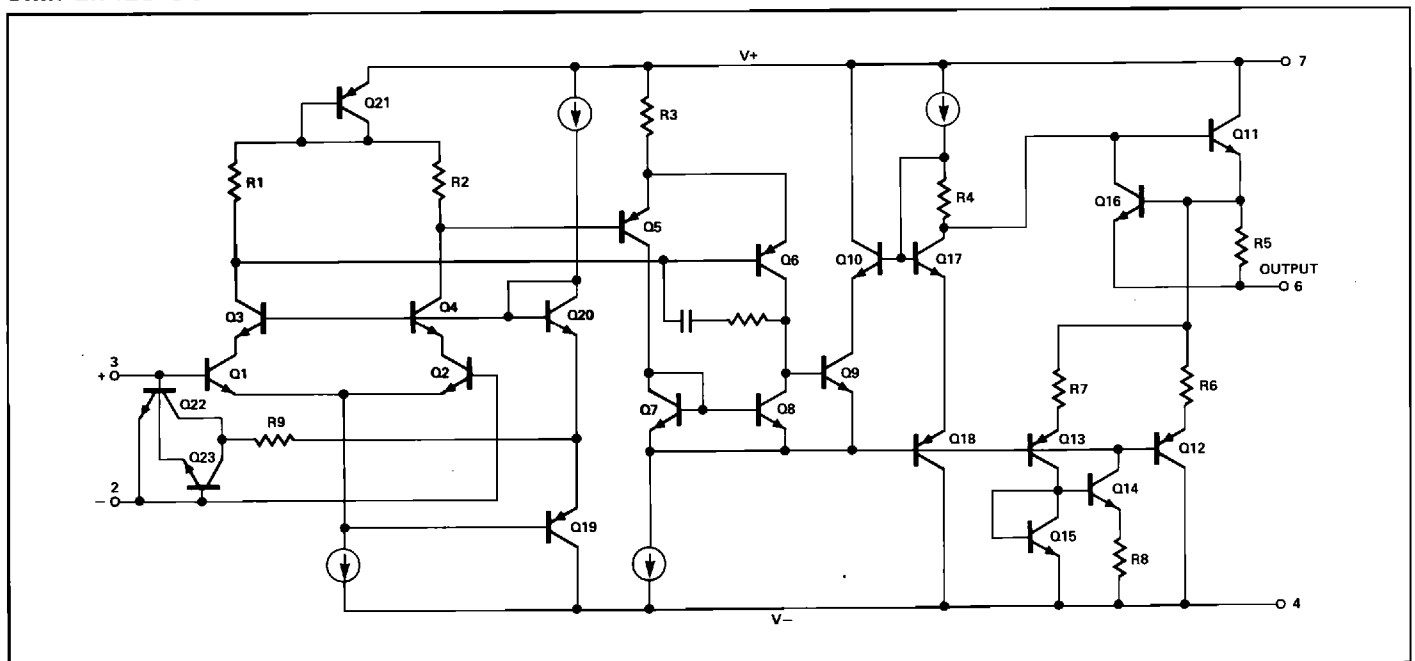

OP-12

ABSOLUTE MAXIMUM RATINGS (Note 4)

Supply Voltage	
OP-12A, OP-12B,	
OP-12E, OP-12F, All DICE except GR	±20V
OP-12G, GR DICE Only	±18V
Operating Temperature Range	
OP-12A, OP-12B	-55°C to +125°C
OP-12E, OP-12F, OP-12G	0°C to +70°C
Storage Temperature Range	-65°C to +150°C
Lead Temperature Range (Soldering, 60 sec)	300°C
Differential Input Current (Note 1)	±10mA
Input Voltage (Note 2)	±15V
Output Short-Circuit Duration	Indefinite
Junction Temperature (T _J)	-65°C to +150°C

PACKAGE TYPE	θ_{JA} (NOTE 3)	θ_{JC}	UNITS
TO-99 (J)	170	24	°C/W
8-Pin Hermetic DIP (Z)	162	26	°C/W

NOTES:

- The inputs are shunted with back-to-back diodes for overvoltage protection. Therefore, excessive current will flow if a differential input voltage in excess of 1V is applied between the inputs unless some limiting resistance is provided.
- For supply voltages less than -15V, the absolute maximum input voltage is equal to the supply voltage.
- θ_{JA} is specified for worst case mounting conditions, i.e., θ_{JA} is specified for device in socket for TO and CerDIP packages.
- Absolute maximum ratings apply to both DICE and packaged parts, unless otherwise noted.

ELECTRICAL CHARACTERISTICS at V_S = ±20V and T_A = 25°C for A, B, E and F grades, V_S = ±15V, and T_A = 25°C for C and G grades, unless otherwise noted.

PARAMETER	SYMBOL	CONDITIONS	OP-12A/E			OP-12B/F			OP-12G			UNITS
			MIN	TYP	MAX	MIN	TYP	MAX	MIN	TYP	MAX	
Input Offset Voltage	V _{OS}		—	0.07	0.15	—	0.18	0.30	—	0.25	1.0	mV
Input Offset Current	I _{OS}		—	0.05	0.20	—	0.05	0.20	—	0.08	0.50	nA
Input Bias Current	I _B		—	0.8	2.0	—	0.8	2.0	—	1.0	5.0	nA
Input Resistance — Differential-Mode	R _{IN}	(Note 1)	26	70	—	26	70	—	10	50	—	MΩ
Input Voltage Range	IVR	V _S = ±15V	±13	±14	—	±13	±14	—	±13	±14	—	V
Common-Mode Rejection Ratio	CMRR	V _{CM} = ±13V	104	120	—	104	120	—	84	116	—	dB
Power Supply Rejection Ratio	PSRR	V _S = ±5V to ±15V	—	1	7	—	1	7	—	4	63	μV/V
Output Voltage Swing	V _O	R _L ≥ 10kΩ, V _S = ±15V R _L ≥ 2kΩ, V _S = ±15V	±13 ±10	±14 ±12	—	±13 ±10	±14 ±12	—	±13 ±10	±14 ±12	—	V
Large-Signal Voltage Gain	A _{VO}	R _L ≥ 10kΩ V _O = ±10V R _L ≥ 2kΩ V _O = ±10V	80 50	300 150	—	80 50	300 150	—	40 —	250 100	—	V/mV
Power Consumption	P _d	V _S = ±15V, No Load V _S = ±5V, No Load	— —	9 3	18 6	— —	9 3	18 6	— —	12 4	24 8	mW
Input Noise Voltage	e _{np-p}	0.1Hz to 10Hz	—	0.9	—	—	0.9	—	—	0.9	—	μV _{p-p}
Input Noise Voltage Density	e _n	f _O = 10Hz f _O = 100Hz f _O = 1000Hz	— — —	22 21 20	— — —	— — —	22 21 20	— — —	— — —	22 21 20	—	nV/√Hz
Input Noise Current	i _{np-p}	0.1Hz to 10Hz	—	3	—	—	3	—	—	3	—	pA _{p-p}
Input Noise Current Density	i _n	f _O = 10Hz f _O = 100Hz f _O = 1000Hz	— — —	0.15 0.14 0.13	— — —	— — —	0.15 0.14 0.13	— — —	— — —	0.15 0.14 0.13	—	pA/√Hz
Slew Rate	SR	R _L ≥ 2kΩ	—	0.12	—	—	0.12	—	—	0.12	—	V/μs
Closed-Loop Bandwidth	BW	A _{VCL} = +1	—	0.80	—	—	0.80	—	—	0.80	—	MHz
Open-Loop Output Resistance	R _O	V _O = 0, I _O = 0	—	200	—	—	200	—	—	200	—	Ω

NOTE:

- Guaranteed by input bias current.

ELECTRICAL CHARACTERISTICS at $V_S = \pm 20V$ for A and B grades, $-55^\circ C \leq T_A \leq +125^\circ C$, unless otherwise noted.

PARAMETER	SYMBOL	CONDITIONS	OP-12A			OP-12B			UNITS
			MIN	TYP	MAX	MIN	TYP	MAX	
Input Offset Voltage	V_{OS}		-	0.12	0.35	-	0.28	0.60	mV
Average Input Offset Voltage Drift	TCV_{OS}		-	0.50	2.5	-	1.0	3.5	$\mu V/^\circ C$
Input Offset Current	I_{OS}		-	0.12	0.40	-	0.12	0.40	nA
Average Input Offset Current Drift	TCI_{OS}		-	0.50	2.5	-	0.50	2.5	$\mu A/^\circ C$
Input Bias Current	I_B		-	1.2	3.0	-	1.2	3.0	nA
Input Voltage Range	IVR	$V_S = \pm 15V$	± 13	± 14	-	± 13	± 14	-	V
Common-Mode Rejection Ratio	CMRR	$V_{CM} = \pm 13V$	100	116	-	100	116	-	dB
Power Supply Rejection Ratio	PSRR	$V_S = \pm 5$ to $\pm 15V$	-	4	10	-	4	10	$\mu V/V$
Large-Signal Voltage Gain	A_{VO}	$R_L \geq 5k\Omega$ $V_O = \pm 10V$	40	120	-	40	120	-	V/mV
Output Voltage Swing	V_O	$R_L \geq 10k\Omega, V_S = \pm 15V$ $R_L \geq 5k\Omega, V_S = \pm 15V$	± 13 ± 10	± 14 ± 13	-	± 13 ± 10	± 14 ± 13	-	V
Power Consumption	P_d	$V_S = \pm 15V$, No Load	-	9	18	-	9	18	mW

ELECTRICAL CHARACTERISTICS at $V_S = \pm 15V$ for G grade, $V_S = \pm 20V$ for E and F grades, $0^\circ C \leq T_A \leq 70^\circ C$, unless otherwise noted.

PARAMETER	SYMBOL	CONDITIONS	OP-12E			OP-12F			OP-12G			UNITS
			MIN	TYP	MAX	MIN	TYP	MAX	MIN	TYP	MAX	
Input Offset Voltage	V_{OS}		-	0.10	0.26	-	0.23	0.45	-	0.32	1.4	mV
Average Input Offset Voltage Drift	TCV_{OS}		-	0.50	2.5	-	1.0	3.5	-	1.5	10	$\mu V/^\circ C$
Input Offset Current	I_{OS}		-	0.08	0.30	-	0.11	0.60	-	0.12	0.70	nA
Average Input Offset Current Drift	TCI_{OS}		-	0.50	2.5	-	1.0	5.0	-	1.0	5.0	$\mu A/^\circ C$
Input Bias Current	I_B		-	1.0	2.6	-	1.2	5.2	-	1.4	6.5	nA
Input Voltage Range	IVR	$V_S = \pm 15V$	± 13	± 14	-	± 13	± 14	-	± 13	± 14	-	V
Common-Mode Rejection Ratio	CMRR	$V_{CM} = \pm 13V$	100	116	-	100	116	-	80	112	-	dB
Power Supply Rejection Ratio	PSRR	$V_S = \pm 5$ to $\pm 15V$	-	4	10	-	4	10	-	6	100	$\mu V/V$
Large-Signal Voltage Gain	A_{VO}	$R_L \geq 10k\Omega$ $V_O = \pm 10V$	60	200	-	60	200	-	25	150	-	V/mV
		$R_L \geq 2k\Omega$ $V_O = \pm 10V$	25	100	-	25	100	-	-	80	-	
Output Voltage Swing	V_O	$R_L \geq 10k\Omega$ $V_S = \pm 15V$	± 13	± 14	-	± 13	± 14	-	± 13	± 14	-	V
		$R_L \geq 5k\Omega$ $V_S = \pm 15V$	± 10	± 12	-	± 10	± 12	-	± 10	± 12	-	
Power Consumption	P_d	$V_S = \pm 15V$, No Load	-	9	18	-	9	18	-	15	24	mW

For typical performance characteristics, see OP-08 data sheet. Assume $C_C = 30pF$.

OP-12

DICE CHARACTERISTICS (125°C TESTED DICE AVAILABLE)

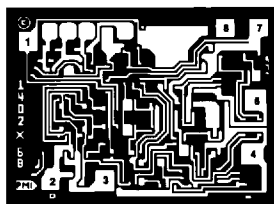

1. NO CONNECTION
2. INVERTING INPUT
3. NONINVERTING INPUT
4. V⁻
6. OUTPUT
7. V⁺
8. NO CONNECTION

DIE SIZE 0.059 × 0.043 inch, 2537 sq. mils
(1.50 × 1.09 mm, 1.64 sq. mm)

WAFER TEST LIMITS at $V_S = \pm 15V$, $T_A = 25^\circ C$ for OP-12N, OP-12G and OP-12GR devices; $T_A = 125^\circ C$ for OP-12NT and OP-12GT devices, unless otherwise noted. (Note 2)

PARAMETER	SYMBOL	CONDITIONS	OP-12NT LIMIT	OP-12N LIMIT	OP-12GT LIMIT	OP-12G LIMIT	OP-12GR LIMIT	UNITS
Input Offset Voltage	V_{OS}		0.35	0.15	0.6	0.3	1	mV MAX
Input Offset Current	I_{OS}		0.4	0.2	0.4	0.2	0.5	nA MAX
Input Bias Current	I_B		3	2	3	2	5	nA MAX
Input Voltage Range	IVR		± 13	± 13	± 13	± 13	± 13	V MIN
Common-Mode Rejection Ratio	CMRR	$V_{CM} = \pm 13V$	100	104	100	104	84	dB MIN
Power Supply Rejection Ratio	PSRR	$V_S = \pm 5V$ to $\pm 15V$	10	7	10	7	63	$\mu V/V$ MAX
Output Voltage Swing	V_O	$R_L \geq 10k\Omega$	± 13	± 13	± 13	± 13	± 13	V MIN
		$R_L \geq 2k\Omega$	—	± 10	—	± 10	± 10	
		$R_L \geq 5k\Omega$	± 10	—	± 10	—	—	
Large-Signal Voltage Gain	A_{VO}	$R_L \geq 10k\Omega$, $V_O = \pm 10V$	80	80	80	80	40	V/mV MIN
		$R_L \geq 2k\Omega$, $V_O = \pm 10V$	—	50	—	50	—	
		$R_L \geq 5k\Omega$, $V_O = \pm 10V$	40	—	40	—	—	
Input Resistance	R_{IN}	(Note 1)	26	26	26	26	10	M Ω MIN
Supply Current	I_{SY}	$I_{OUT} = 0$ $V_{OUT} = 0$	0.6	0.6	0.6	0.6	0.8	mA MAX

- NOTES:**
1. Guaranteed by design.
 2. For 25°C specifications of OP-12NT and OP-12GT, see OP-12N and OP-12G, respectively.

Electrical tests are performed at wafer probe to the limits shown. Due to variations in assembly methods and normal yield loss, yield after packaging is not guaranteed for standard product dice. Consult factory to negotiate specifications based on dice lot qualification through sample lot assembly and testing.

TYPICAL ELECTRICAL CHARACTERISTICS at $V_S = \pm 15V$, unless otherwise noted.

PARAMETER	SYMBOL	CONDITIONS	OP-12NT TYPICAL	OP-12N TYPICAL	OP-12GT TYPICAL	OP-12G TYPICAL	OP-12GR TYPICAL	UNITS
Average Input Offset Voltage Drift	TCV_{OS}		0.5	0.5	1.0	1.0	1.5	$\mu V/^\circ C$
Average Input Offset Current Drift	TCI_{OS}		0.5	0.5	1.0	1.0	1.0	pA/°C