

TMC3533

Triple Video D/A Converter

8 bit, 80 Msp, 3.3V

Features

- 8-bit resolution
- 80, 50, and 30 megapixels per second
- ± 0.5 LSB linearity error
- Sync, blank, and white controls
- Independent sync current output
- 1.0V p-p video into 37.5Ω or 75Ω load
- Enhancement of the ADV7120
 - Internal bandgap voltage reference
 - Double-buffered data for low distortion
 - Power-down sleep mode
- Double-buffered data for low distortion
- TTL-compatible inputs
- Low glitch energy
- Single $+3.3V \pm 5\%$ Volt power supply

Applications

- Video and graphics displays
- Image processing systems
- Video signal conversion
- Broadcast television equipment
- Digital synthesis

Description

The TMC3533 is a high-speed triple 8-bit D/A converter especially suited for video and graphics applications. It offers 8-bit resolution, TTL-compatible inputs, low power consumption, a power-down sleep mode, and requires only a single $+3.3V \pm 5\%$ Volt power supply. It has single-ended current outputs, $\overline{\text{SYNC}}$, $\overline{\text{BLANK}}$, $\overline{\text{WHITE}}$, and $\overline{\text{SLEEP}}$ control inputs, and a separate current source for adding sync pulses to any D/A converter output. It is ideal for generating analog RGB from digital RGB and driving computer display and video monitors. Three speed grades are available: 30, 50, and 80 Msp.

The TMC3533 triple D/A converter is available in a 44-lead plastic J-leaded PLCC. It is also available in a 48-lead plastic LQFP package. It is fabricated on a sub-micron CMOS process with performance guaranteed from 0°C to 70°C .

Block Diagram

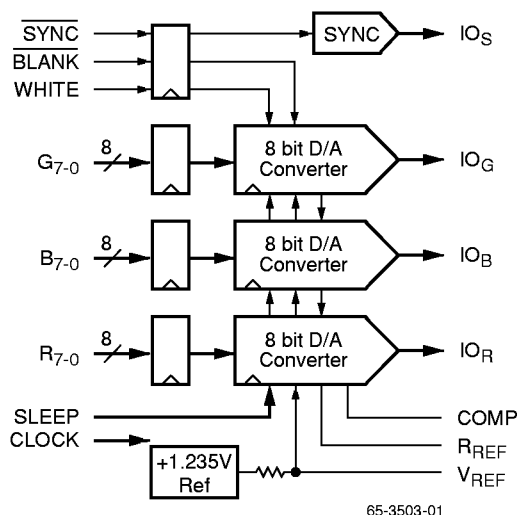

65-3503-01

Functional Description

The TMC3533 is a low-cost triple 8-bit CMOS D/A converter designed to directly drive computer CRT displays at pixel rates up to 80 Msps. It comprises three identical 8-bit D/A converters with registered data inputs, common clock, and internal voltage reference. An independent current source allows sync to be added to any D/A converter output.

Digital Inputs

All digital inputs are TTL-compatible. Data are registered on the rising edge of the CLK signal. The analog output changes t_{DO} after the rising edge of CLK. There is one stage of pipeline delay on the chip. The guaranteed clock rates of the TMC3533 are 80, 50, and 30 MHz.

SYNC and BLANK

$\overline{\text{SYNC}}$ and $\overline{\text{BLANK}}$ inputs control the output level (Figure 1 and Table 1) of the D/A converters during CRT retrace intervals. $\overline{\text{BLANK}}$ forces the D/A outputs to the blanking level while $\overline{\text{SYNC}}$ turns off a separate current source which is brought off the chip through the IOS pin.

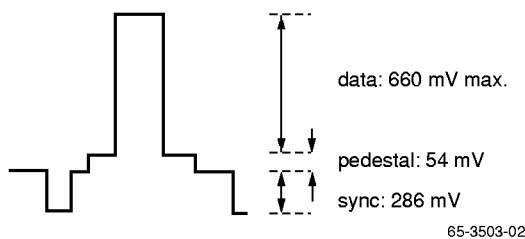

Figure 1. Nominal Output Levels

IOS may be connected to any one D/A output, or used independently. It is commonly tied to the green D/A converter for "Sync on Green" operation. This connection adds a 40 IRE sync pulse to the D/A output and brings that D/A output to 0.0 Volts during the sync tip. $\overline{\text{SYNC}}$ and $\overline{\text{BLANK}}$ are registered on the rising edge of CLK.

$\overline{\text{BLANK}}$ gates the D/A inputs and sets the pedestal voltage. If $\overline{\text{BLANK}} = \text{HIGH}$, the D/A inputs are added to a pedestal which offsets the current output. If $\overline{\text{BLANK}} = \text{LOW}$, data inputs and the pedestal are disabled.

WHITE

The WHITE control drives all three D/As to full-scale, overriding the data inputs. It is overridden by the $\overline{\text{BLANK}}$ input, and is independent of $\overline{\text{SYNC}}$.

SLEEP

The SLEEP control, when HIGH, places the TMC3533 in a power-down state. This function operates asynchronously.

D/A Outputs

Each D/A output is a current source. To obtain a voltage output, a resistor must be connected to ground. Output voltage depends upon this external resistor, the reference voltage, and the value of the gain-setting resistor connected between RREF and GND.

Normally, a source termination resistor of 75 Ohms is connected between the D/A current output pin and GND near the D/A converter. A 75 Ohm coaxial cable may then be connected with another 75 Ohm termination resistor at the far end of the cable. This "double termination" presents the D/A converter with a net resistive load of 37.5 Ohms.

The TMC3533 may also be operated with a single 75 Ohm terminating resistor. To lower the output voltage swing to the desired range, the value of the resistor on RREF should be increased.

Voltage Reference

The TMC3533 has an internal bandgap voltage reference of +1.235 Volts. An external voltage reference may be connected to the VREF pin, overriding the internal voltage reference. All three D/A converters are driven from the same reference.

A 0.1 μF capacitor must be connected between the COMP pin and VDD to stabilize internal bias circuitry and ensure low-noise operation.

Power and Ground

The TMC3533 D/A converter requires a single +3.3 Volt power supply. The analog (VDD) power supply voltage should be decoupled to GND to reduce power supply induced noise. 0.1 μF decoupling capacitors should be placed as close as possible to the power pins.

The high slew-rate of digital data makes capacitive coupling to the outputs of any D/A converter a potential problem. Since the digital signals contain high-frequency components of the CLK signal, as well as the video output signal, the resulting data feedthrough often looks like harmonic distortion or reduced signal-to-noise performance. All ground pins should be connected to a common solid ground plane for best performance.

Table 1. Output Voltage versus Input Code, SYNC, BLANK, and WHITE

VREF = 1.235 V, RREF = 572 Ω, RL = 37.5 Ω

RGB7-0 (MSB...LSB)	All D/As				D/A with IOS Connected			
	SYNC	BLANK	WHITE	VOUT	SYNC	BLANK	WHITE	VOUT
XXXX XXXX	X	1	1	0.714	1	1	1	1.000
1111 1111	X	1	0	0.714	1	1	0	1.000
1111 1110	X	1	0	0.711	1	1	0	0.997
1111 1101	X	1	0	0.709	1	1	0	0.995
⋮	⋮	⋮	⋮	⋮	⋮	⋮	⋮	⋮
0000 0000	X	1	0	0.385	1	1	0	0.671
1111 1111	X	1	0	0.383	1	1	0	0.669
⋮	⋮	⋮	⋮	⋮	⋮	⋮	⋮	⋮
0000 0010	X	1	0	0.059	1	1	0	0.345
0000 0001	X	1	0	0.057	1	1	0	0.343
0000 0000	X	1	0	0.054	1	1	0	0.340
XXXX XXXX	X	0	X	0.000	1	0	X	0.286
XXXX XXXX	X	0	X	0.000	0	0	X	0.000

Pin Assignments

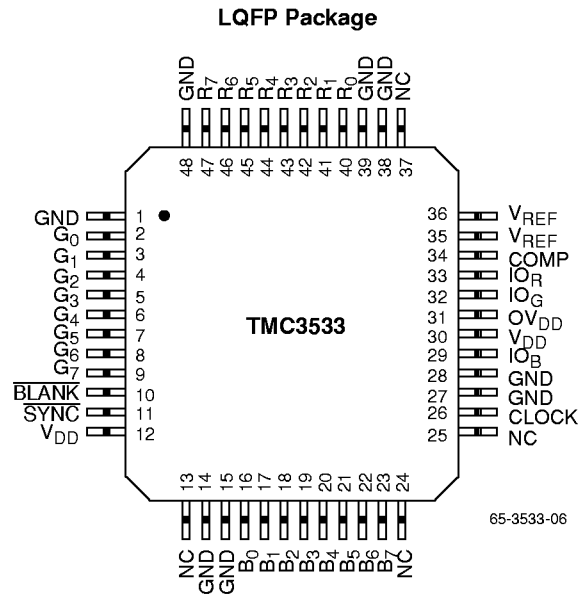
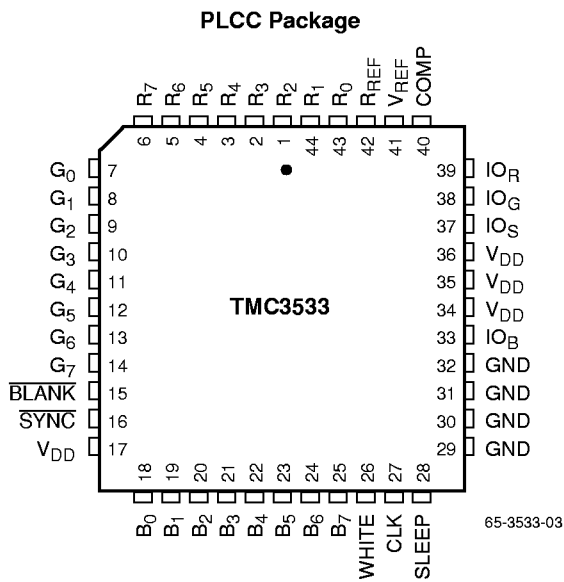

Note: In LQFP Package, pin functions White and Sleep are not available. Also IOs function is tied internally to IOG pin.

Pin Descriptions

Pin Name	Pin Number		Value	Pin Function Description
	LQFP	PLCC		
Clock and Pixel I/O				
CLK	26	27	TTL	Clock Input. The clock input is TTL-compatible and all pixel data is registered on the rising edge of CLK. It is recommended that CLK be driven by a dedicated TTL buffer to avoid reflection induced jitter, overshoot, and undershoot.
R7-0 G7-0 B7-0	47-40 9-2 23-16	6-1, 44-43 14-7 25-18	TTL	Red, Green, and Blue Pixel Inputs. The R, G, and B digital inputs are TTL-compatible and registered on the rising edge of CLK.
Controls				
SYNC	11	16	TTL	Sync Pulse Input. Bringing $\overline{\text{SYNC}}$ LOW, turns off a 40 IRE (7.62 mA) current source which forms a sync pulse on any D/A converter output connected to IOs. $\overline{\text{SYNC}}$ is registered on the rising edge of CLK along with pixel data and has the same pipeline latency as $\overline{\text{BLANK}}$ and pixel data. $\overline{\text{SYNC}}$ does not override any other data and should be used only during the blanking interval. If the system does not require sync pulses, $\overline{\text{SYNC}}$ and IOs should be connected to GND.
BLANK	10	15	TTL	Blanking Input. When $\overline{\text{BLANK}}$ is LOW, pixel inputs are ignored and the D/A converter outputs are driven to the blanking level. $\overline{\text{BLANK}}$ is registered on the rising edge of CLK and has the same two-pipe latency as $\overline{\text{SYNC}}$ and Data.
WHITE	—	26	TTL	Force Full Scale Input. When WHITE is HIGH, pixel inputs are ignored and the D/A converter outputs are driven to their full-scale output level. A $\overline{\text{BLANK}}$ input overwrites a WHITE input. WHITE is register on the rising edge of CLK and has the same two-pipe latency as $\overline{\text{SYNC}}$ and Data.
SLEEP	—	28	TTL	Power-down Control Input. When HIGH, SLEEP places the D/A converter in a low-power-dissipation mode. The D/A current sources and the digital processing are disabled. The last data loaded into the input and D/A registers is retained. This control is asynchronous.
Video Outputs				
IOR IOG IOB	33 32 29	39 38 33	0.714 V _{p-p}	Red, Green, and Blue Data Outputs. The current source outputs of the D/A converters are capable of driving RS-343A/SMPTE-170M compatible levels into doubly-terminated 75 Ohm lines. Sync pulses may be added to any D/A output.
IOS	32	37	0.714 V _{p-p}	SYNC Current Output. When this pin is connected to any of the D/A converter outputs, a 40 IRE offset is added to the video level. When the $\overline{\text{SYNC}}$ input is LOW, the current is turned off, bring the sync tip voltage to 0.0V. If no sync pulse is required, IOS should be grounded. When $\overline{\text{SYNC}}$ is HIGH, the current flowing out of IOS is: IOS = 3.64 (VREF / RREF)
Voltage Reference				
VREF	35	41	+1.235 V	Voltage Reference Input/Output. An internal voltage source of +1.235 Volts is output on this pin. An external +1.235 Volt reference may be applied here which overrides the internal reference. Decoupling VREF to GND with a 0.1μF ceramic capacitor is required.

Pin Descriptions (continued)

Pin Name	Pin Number		Value	Pin Function Description
	LQFP	PLCC		
RREF	36	42	572 Ω	<p>Current-setting Resistor. The full-scale output current of each D/A converter is determined by the value of the resistor connected between RREF and GND. The nominal value for RREF is found from:</p> $R_{REF} = 9.1 (V_{REF}/I_{FS}),$ <p>but is optimized to be 572 Ω. I_{FS} is the full-scale (white) output current (amps) from an output without sync. Sync current is 0.4 I_{FS}.</p> <p>D/A full-scale (white) current may also be calculated from:</p> $I_{FS} = V_{FS}/R_L$ <p>Where V_{FS} is the white voltage level and R_L is the total resistive load (ohms) on each D/A converter. V_{FS} is the blank to full-scale voltage.</p>
COMP	34	40	0.1 μF	<p>Compensation Capacitor. A 0.1 μF ceramic capacitor must be connected between COMP and V_{DD} to stabilize internal bias circuitry.</p>
Power, Ground				
VDD	12, 30, 31	17, 34–36	+3.3 V	Power Supply.
GND	1, 14, 15, 27, 28, 38, 39, 48	29–32	0.0V	Ground.
NC	13, 24, 25, 37	—	—	No Connect

Equivalent Circuits

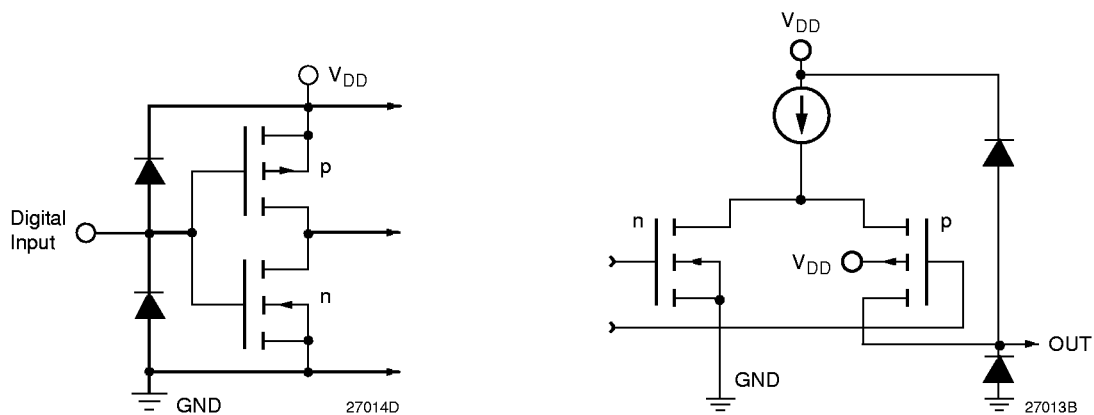

Figure 2. Equivalent Digital Input Circuit Figure 3. Equivalent Analog Output Circuit

Equivalent Circuits (continued)

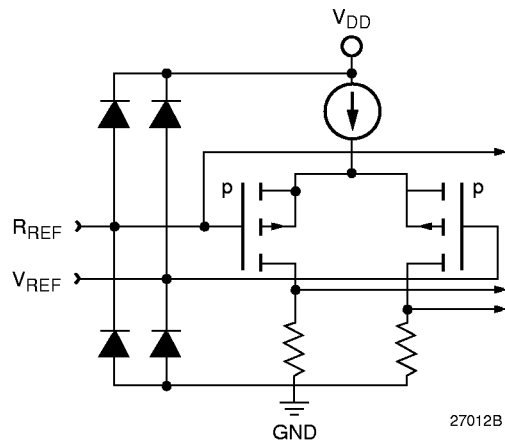

Figure 4. Equivalent Analog Input Circuit

Absolute Maximum Ratings (beyond which the device may be damaged)¹

Parameter	Min	Typ	Max	Unit
Power Supply Voltage				
VDD (Measured to GND)	-0.5		7.0	V
Inputs				
Applied Voltage (measured to GND) ²	-0.5		VDD + 0.5	V
Forced Current ^{3,4}	-10.0		10.0	mA
Outputs				
Applied Voltage (measured to GND) ²	-0.5		VDD + 0.5	V
Forced Current ^{3,4}	-60.0		60.0	mA
Short Circuit Duration (single output in HIGH state to ground)			infinite	second
Temperature				
Operating, Ambient	-20		110	°C
Junction			150	°C
Lead Soldering (10 seconds)			300	°C
Vapor Phase Soldering (1 minute)			220	°C
Storage	-65		150	°C

Notes:

- Functional operation under any of these conditions is NOT implied. Performance and reliability are guaranteed only if Operating Conditions are not exceeded.
- Applied voltage must be current limited to specified range.
- Forcing voltage must be limited to specified range.
- Current is specified as conventional current flowing into the device.

Operating Conditions

Parameter			Min	Nom	Max	Units
VDD	Power Supply Voltage		3.135	3.3	3.465	V
fs	Conversion Rate	TMC3533-30			30	Msps
		TMC3533-50			50	Msps
		TMC3533-80			80	Msps
tPWH	CLK Pulsewidth, HIGH		4		ns	
tPWL	CLK Pulsewidth, LOW		4		ns	
ts	Input Data Setup Time		3		ns	
th	Input Date Hold Time		2		ns	
VREF	Reference Voltage, External		1.0	1.235	1.5	V
Cc	Compensation Capacitor			0.1		μ F
RL	Output Load			37.5		Ω
VIH	Input Voltage, Logic HIGH		2.0		V _{DD}	V
VIL	Input Voltage, Logic LOW		GND		0.8	V
TA	Ambient Temperature, Still Air		0		70	$^{\circ}$ C

Electrical Characteristics

Parameter		Conditions ³	Min	Typ ¹	Max	Units
IDD	Power Supply Current ²	VDD = Max			95	mA
		TMC3533-30			95	mA
		TMC3533-80			105	mA
IDDS	Power Supply Current, Sleep Mode	VDD = Max			3	mA
PD	Total Power Dissipation ²	VDD = Max			330	mW
		TMC3533-30			330	mW
		TMC3533-80			346	mW
RO	Output Resistance			100	k Ω	
CO	Output Capacitance	I _{OUT} = 0mA			30	pF
I _{IH}	Input Current, HIGH	VDD = Max, V _{IN} = 3.0V			-1	μ A
I _{IL}	Input Current, LOW	VDD = Max, V _{IN} = 0.4V			1	μ A
I _{REF}	VREF Input Bias Current			0	\pm 100	μ A
VREF	Reference Voltage Output			1.235		V
VOC	Output Compliance	Referred to VDD	-0.4	0	+1.5	V
CDI	Digital Input Capacitance			4	10	pF

Notes:

1. Values shown in Typ column are typical for V_{DD} = +3.3V and T_A = 25 $^{\circ}$ C
2. Minimum/Maximum values with V_{DD} = Max and T_A = Min
3. V_{REF} = 1.235V, R_{LOAD} = 37.5 Ω , R_{REF} = 572 Ω

Switching Characteristics

Parameter	Conditions ²	Min	Typ ¹	Max	Units
t _D	Clock to Output Delay	V _{DD} = Min	10	15	ns
t _{SKEW}	Output Skew		1	2	ns
t _R	Output Risetime	10% to 90% of Full Scale	3	4	ns
t _F	Output Falltime	90% to 10% of Full Scale	3	4	ns
t _{SET}	Output Settling Time	to 3%/FS	15		ns

Notes:

1. Values shown in Typ column are typical for V_{DD} = +3.3V and T_A = 25°C.
2. V_{REF} = 1.235V, R_{LOAD} = 37.5Ω, R_{REF} = 572Ω.

System Performance Characteristics

Parameter	Conditions ²	Min	Typ ¹	Max	Units
ELI	Integral Linearity Error	V _{DD} , V _{REF} = Nom	±0.1	±0.25	%/FS
ELD	Differential Linearity Error	V _{DD} , V _{REF} = Nom	±0.1	±0.25	%/FS
EDM	DAC to DAC Matching	V _{DD} , V _{REF} = Nom	7	10	%
VOF	Output Offset Current	V _{DD} = Max, R, G, B = 000h SYNC = BLANK = 0		20	mA
PSRR	Power Supply Rejection Ratio			0.05	%/%

Notes:

1. Values shown in Typ column are typical for V_{DD} = +3.3V and T_A = 25°C.
2. V_{REF} = 1.235V, R_{LOAD} = 37.5Ω, R_{REF} = 572Ω.

Timing Diagram

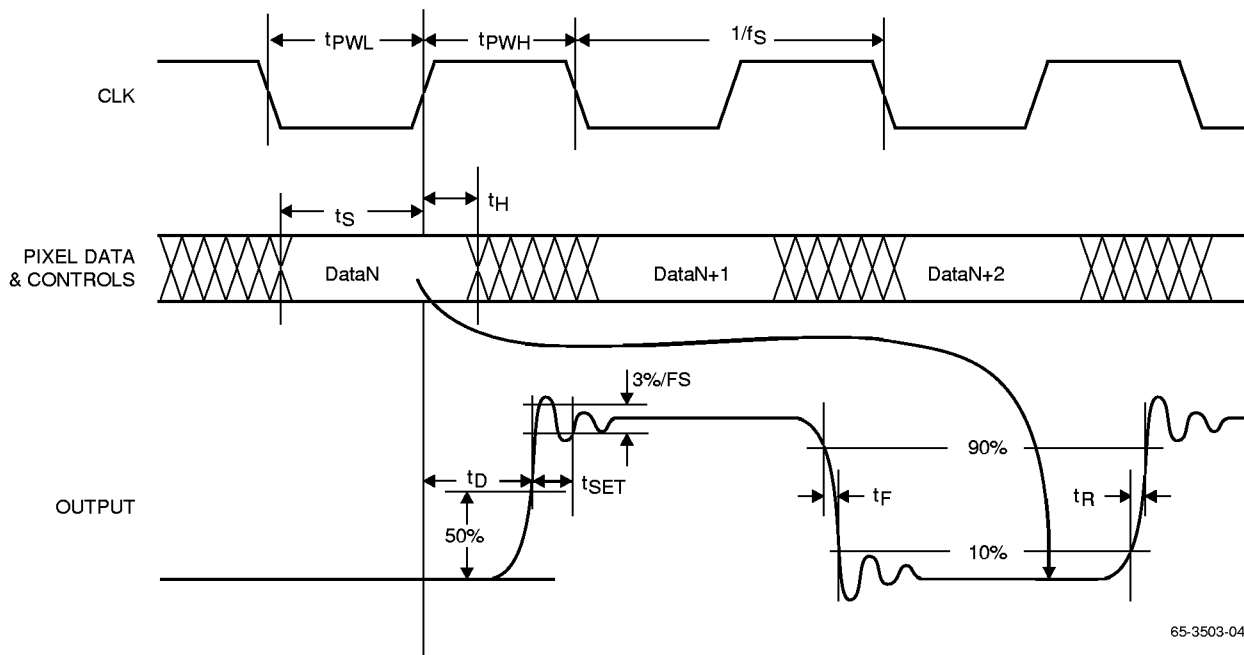

65-3503-04

Application Notes

Figure 4 illustrates a typical TMC3533 interface circuit. In this example, an optional 1.2 Volt bandgap reference is connected to the VREF output, overriding the internal voltage reference source.

Grounding

It is important that the TMC3533 power supply is well-regulated and free of high-frequency noise. Careful power supply decoupling will ensure the highest quality video signals at the output of the circuit. The TMC3533 has separate analog and digital circuits. To keep digital system noise from the D/A converter, it is recommended that power supply voltages (VDD) come from the system analog power source and all ground connections (GND) be made to the analog ground plane. Power supply pins should be individually decoupled at the pin.

Printed Circuit Board Layout

Designing with high-performance mixed-signal circuits demands printed circuits with ground planes. Overall system performance is strongly influenced by the board layout. Capacitive coupling from digital to analog circuits may result in poor D/A conversion. Consider the following suggestions when doing the layout:

1. Keep the critical analog traces (VREF, IREF, COMP, IOS, IOR, IOG, IOB) as short as possible and as far as possible from all digital signals. The TMC3533 should be located near the board edge, close to the analog output connectors.

2. The power plane for the TMC3533 should be separate from that which supplies the digital circuitry. A single power plane should be used for all of the VDD pins. If the power supply for the TMC3533 is the same as that of the system's digital circuitry, power to the TMC3533 should be decoupled with 0.1µF and 0.01µF capacitors and isolated with a ferrite bead.
3. The ground plane should be solid, not cross-hatched. Connections to the ground plane should have very short leads.
4. If the digital power supply has a dedicated power plane layer, it should not be placed under the TMC3533, the voltage reference, or the analog outputs. Capacitive coupling of digital power supply noise from this layer to the TMC3533 and its related analog circuitry can have an adverse effect on performance.
5. CLK should be handled carefully. Jitter and noise on this clock will degrade performance. Terminate the clock line carefully to eliminate overshoot and ringing.

Related Products

- TMC3003 Triple 10-bit 80 Msp/s D/A Converter
- TMC2242C/TMC2243/TMC2246A Video Filters
- TMC2081 Digital Video Mixer
- TMC3503 Triple Video D/A Converter, 5V
- TMC22x5y Video Decoder

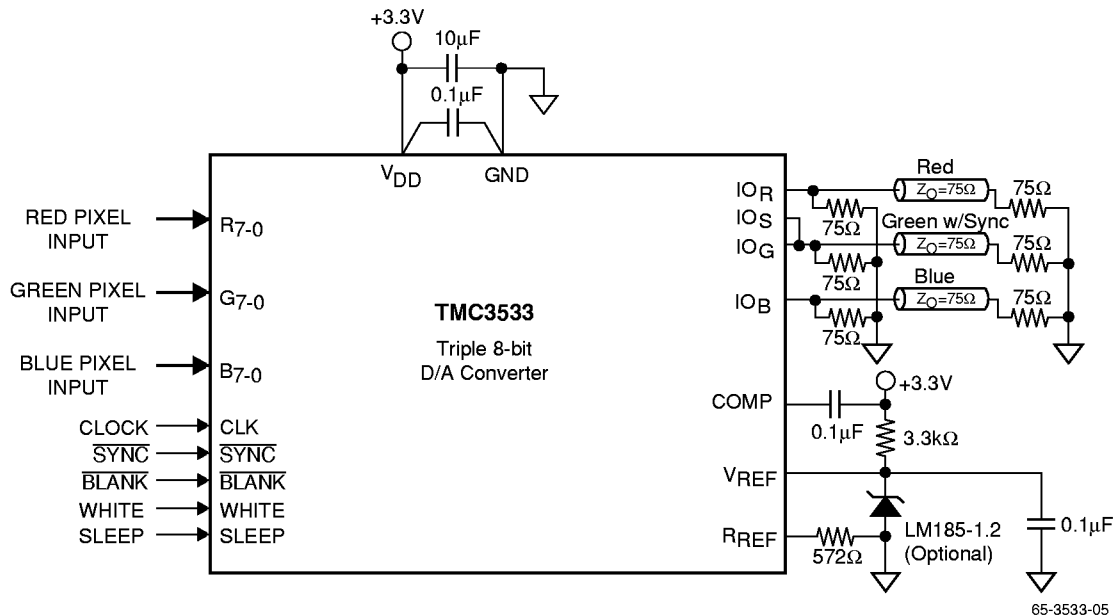

Figure 4. Typical Interface Circuit

65-3533-05

Mechanical Dimensions – 44-pin PLCC Package

Symbol	Inches		Millimeters		Notes
	Min.	Max.	Min.	Max.	
A	.165	.180	4.19	4.57	
A1	.090	.120	2.29	3.05	
A2	.020	—	.51	—	
B	.013	.021	.33	.53	
B1	.026	.032	.66	.81	
D/E	.685	.695	17.40	17.65	
D1/E1	.650	.656	16.51	16.66	3
D3/E3	.500 BSC		12.7 BSC		
e	.050 BSC		1.27 BSC		
J	.042	.056	1.07	1.42	2
ND/NE	11		11		
N	44		44		
ccc	—	.004	—	0.10	

Notes:

1. All dimensions and tolerances conform to ANSI Y14.5M-1982
2. Corner and edge chamfer (J) = 45°
3. Dimension D1 and E1 do not include mold protrusion. Allowable protrusion is .101" (.25mm)

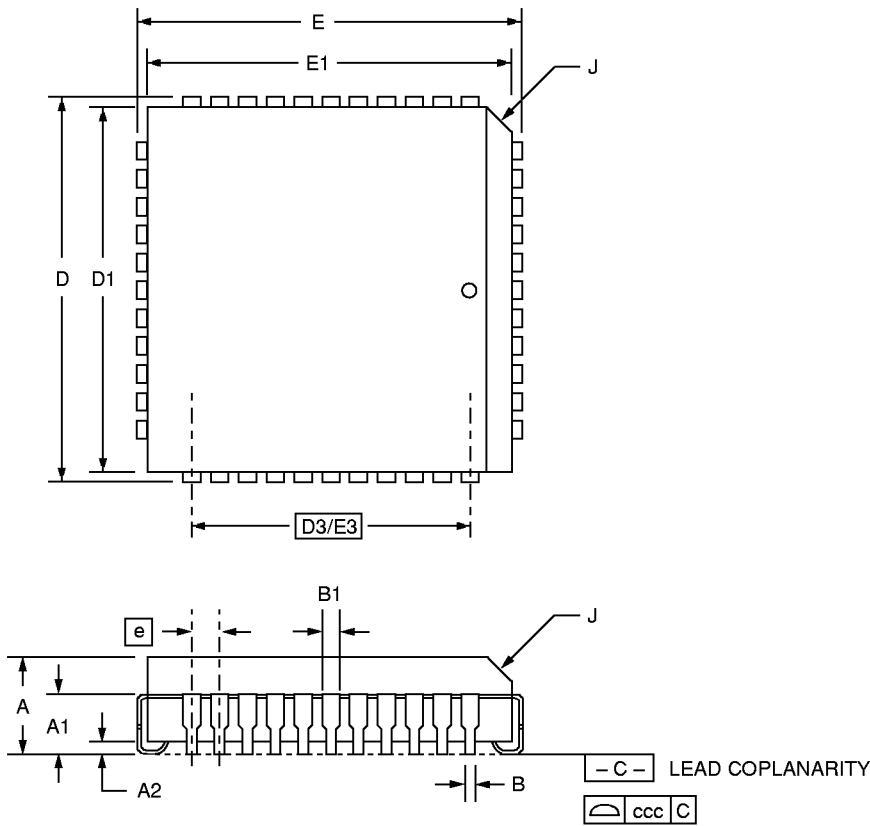

Mechanical Dimensions – 48-pin LQFP Package

Symbol	Inches		Millimeters		Notes
	Min.	Max.	Min.	Max.	
A	.055	.063	1.40	1.60	
A1	.001	.005	.05	.15	
A2	.053	.057	1.35	1.45	
B	.006	.010	.17	.27	7
D/E	.346	.362	8.8	9.2	8
D1/E1	.268	.284	6.8	7.2	2
e	.019 BSC		.50 BSC		
L	.017	.029	.45	.75	6
N	48		48		4
ND	12		12		5
α	0°	7°	0°	7°	
ccc	.004		0.08		

Notes:

1. All dimensions and tolerances conform to ANSI Y14.5M-1982.
2. Dimensions "D1" and "E1" do not include mold protrusion. Allowable protrusion is 0.25mm per side. D1 and E1 are maximum plastic body size dimensions including mold mismatch.
3. Pin 1 identifier is optional.
4. Dimension ND: Number of terminals.
5. Dimension ND: Number of terminals per package edge.
6. "L" is the length of terminal for soldering to a substrate.
7. Dimension "B" does not include dambar protrusion. Allowable dambar protrusion shall not cause the lead width to exceed the maximum B dimension by more than 0.08mm. Dambar can not be located on the lower radius or the foot. Minimum space between protrusion and an adjacent lead is 0.07mm for 0.4mm and 0.5mm pitch packages.
8. To be determined at seating place —C—

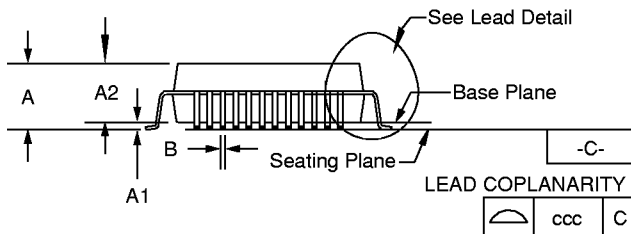
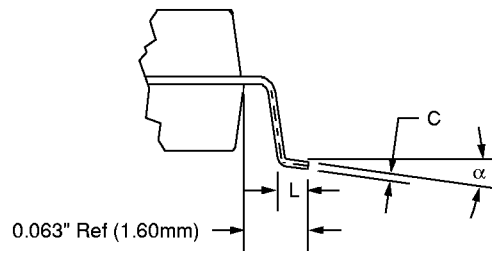
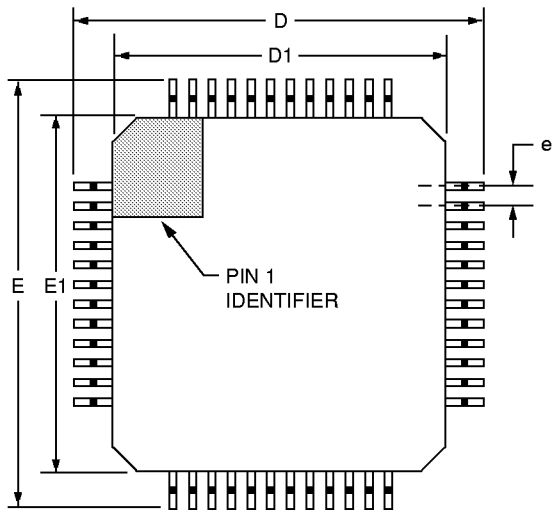

Ordering Information

Product Number	Conversion Rate (Msps)	Temperature Range	Screening	Package	Package Marking
TMC3533R2C30	30 Msps	T _A = 0°C to 70°C	Commercial	44-Lead PLCC	3533LR2C30
TMC3533R2C50	50 Msps	T _A = 0°C to 70°C	Commercial	44-Lead PLCC	3533LR2C50
TMC3533R2C80	80 Msps	T _A = 0°C to 70°C	Commercial	44-Lead PLCC	3533LR2C80
TMC3533KRC30	30 Msps	T _A = 0°C to 70°C	Commercial	48-Lead LQFP	3533LKRC30
TMC3533KRC50	50 Msps	T _A = 0°C to 70°C	Commercial	48-Lead LQFP	3533LKRC50
TMC3533KRC80	80 Msps	T _A = 0°C to 70°C	Commercial	48-Lead LQFP	3533LKRC80

DISCLAIMER

FAIRCHILD SEMICONDUCTOR RESERVES THE RIGHT TO MAKE CHANGES WITHOUT FURTHER NOTICE TO ANY PRODUCTS HEREIN TO IMPROVE RELIABILITY, FUNCTION OR DESIGN. FAIRCHILD DOES NOT ASSUME ANY LIABILITY ARISING OUT OF THE APPLICATION OR USE OF ANY PRODUCT OR CIRCUIT DESCRIBED HEREIN; NEITHER DOES IT CONVEY ANY LICENSE UNDER ITS PATENT RIGHTS, NOR THE RIGHTS OF OTHERS.

LIFE SUPPORT POLICY

FAIRCHILD'S PRODUCTS ARE NOT AUTHORIZED FOR USE AS CRITICAL COMPONENTS IN LIFE SUPPORT DEVICES OR SYSTEMS WITHOUT THE EXPRESS WRITTEN APPROVAL OF THE PRESIDENT OF FAIRCHILD SEMICONDUCTOR CORPORATION. As used herein:

1. Life support devices or systems are devices or systems which, (a) are intended for surgical implant into the body, or (b) support or sustain life, or (c) whose failure to perform when properly used in accordance with instructions for use provided in the labeling, can be reasonably expected to result in significant injury to the user.
2. A critical component is any component of a life support device or system whose failure to perform can be reasonably expected to cause the failure of the life support device or system, or to affect its safety or effectiveness.