

ACDL2V

Class D audio inductor ferrite



Product features

- AEC-Q200
- Shielded construction
- Dual inductors in a single package
- 10.5 mm x 9.5 mm footprint surface mount package in a 10 mm height
- High frequency operation
- Low loss, low ESR
- Ferrite core material
- Moisture Sensitivity Level (MSL) 1

Applications

Automotive Class D audio amplifiers

- Automotive 12 V/24 V/48 V bidirectional
- DC/DC converters
- EV battery chargers
- On-board-chargers
- xEV Electrical systems (multiple phases)

Environmental compliance and general specifications

- Operating temperature range: -40 °C to +125 °C (ambient plus self-temperature rise)
- Storage temperature range (component): -40 °C to +125 °C
- Solder reflow temperature: J-STD-020 (latest revision) compliant



Product specifications

Part number ⁵	OCL ¹ (μH) $\pm 20\%$	I_{rms} ³ (A)	I_{sat} ⁴ (A)	DCR (m Ω) typical @ +25 °C	DCR (m Ω) maximum @ +25 °C	SRF (MHz) reference
ACDL2V0910-4R7-R	4.7	5.2	10	15	18	40
ACDL2V0910-6R8-R	6.8	5.2	7.5	15	18	35
ACDL2V0910-8R2-R	8.2	5.2	6.4	15	18	31
ACDL2V0910-100-R	10	5.0	5.6	16.4	19	25
ACDL2V0910-120-R	12	4.3	5.2	22	25	26
ACDL2V0910-150-R	15	3.5	4.7	32.7	39.2	22.5
ACDL2V0910-220-R	22	2.5	3.5	43	50	18

1. Open circuit inductance (OCL) test parameters: 100 kHz, 1.0 V_{rms}, 0.0 Adc, +25 °C

2. All test data referenced to +25 °C ambient.

3. I_{rms} (per winding): DC current for an approximate temperature rise of 40 °C without core loss. Derating is necessary for AC currents. PCB layout, trace thickness and width, air-flow, and proximity of other heat generating components will affect the temperature rise. It is recommended that the temperature of the part not exceed +125 °C under worst case operating conditions verified in the end application.

4. I_{sat} (per winding): Peak current for approximately 25% rolloff @ +25 °C.

5. Part number definition: ACDL2V0910-xxx-R

(ACDL2V0910)= Product code and size
xxx= inductance value in μH , R= decimal point, if no R is present then last character equals number of zeros
-R suffix = RoHS compliant

Note: Rated DC current: The lower value of I_{rms} or I_{sat} .

Mechanical parameters, schematic, pad layout (mm)

Recommended pad layout

Schematic

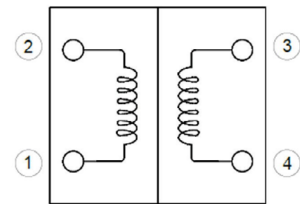
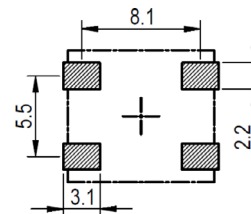
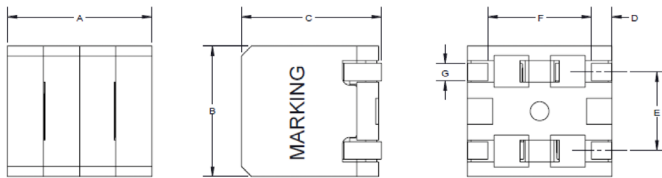

Bottom view

Part number	A	B	C	D	E	F	G
ACDL2V0910	10.0 \pm 0.50	9.0 \pm 0.50	10.0 maximum	1.9 \pm 0.50	5.5 \pm 0.40	6.2 \pm 1.0	1.2 \pm 0.2

Part marking: 2Vxxx

WLY R

xxx = inductance value in μH , R= decimal point. If no R is present last digit equals number of zeros.

WLY R= lot code

PCB layout is for reference

Recommended solder paste thickness at 0.15 mm and above.

Traces or vias underneath the inductor is not recommended

Packaging information (mm)

Drawing not to scale

Supplied in tape and reel packaging, 300 parts per 13" diameter reel (EIA-481 compliant)

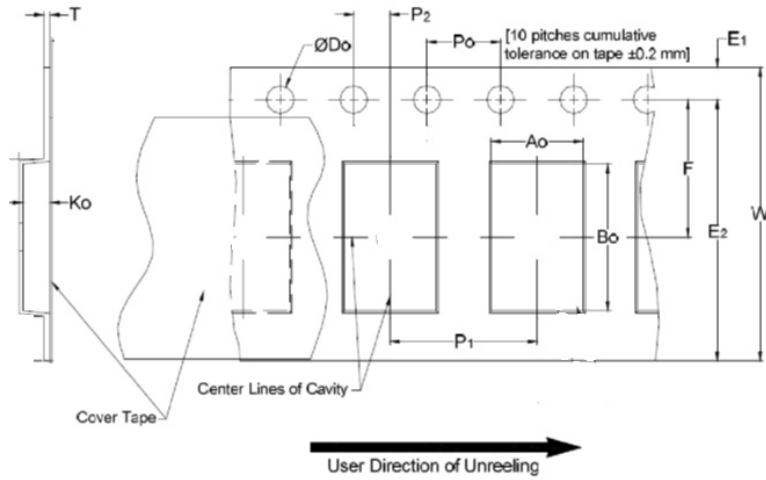

W	24.0 ± 0.3
F	11.5 ± 0.1
E1	1.75 ± 0.10
E2	NA
P0	4.0 ± 0.10
P1	16.0 ± 0.1
P2	2.0 ± 0.1
ØD0	1.5 ± 0.1
A0	9.6 ± 0.1
B0	10.6 ± 0.1
K0	10.5 ± 0.10
T	0.40 ± 0.05

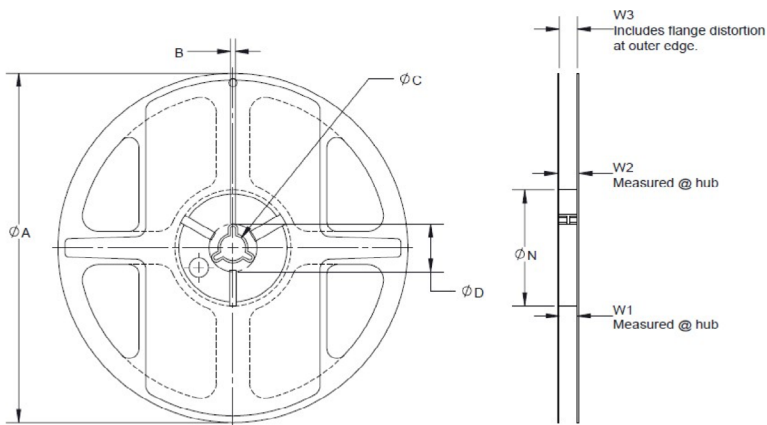

Shape & Appearance For Reference Only

A	330 ± 2
B	2.3 ± 0.3
C	13 + 0.5/-0.2
D	20.2 minimum
N	100 ± 3.0
W1	24.4 + 2.0/-0
W2	30.4 maximum
W3	NA

Inductance and temperature rise vs. I_{dc}

ACDL2V0910-4R7-R

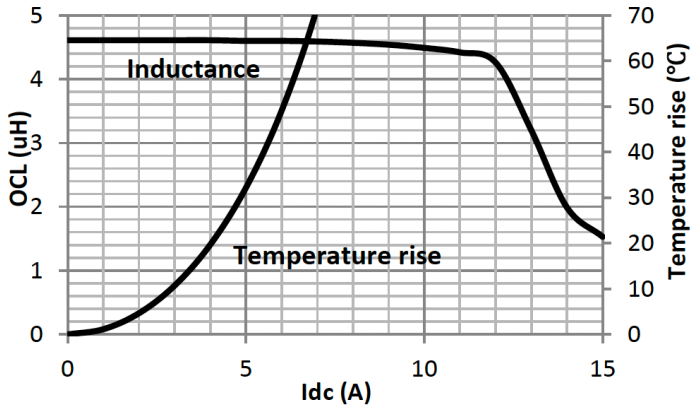

ACDL2V0910-6R8-R

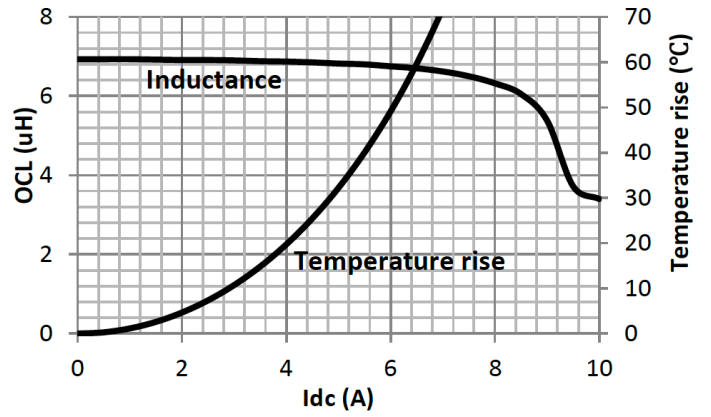

ACDL2V0910-8R2-R

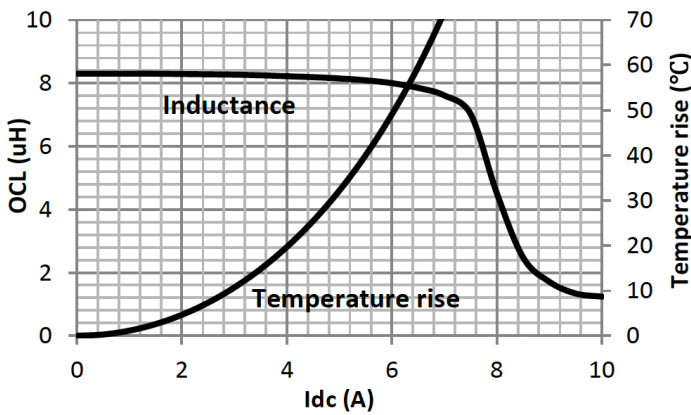

ACDL2V0910-100-R

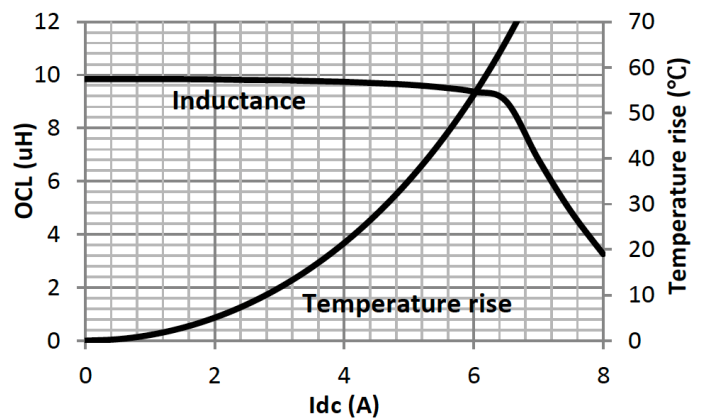

Inductance and temperature rise vs. I_{dc} , continued

ACDL2V0910-120-R

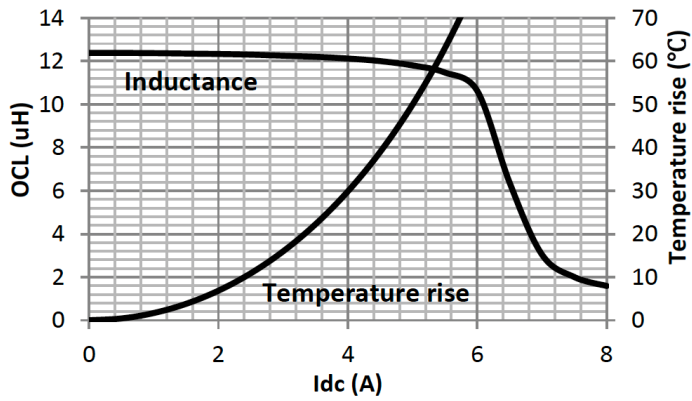

ACDL2V0910-150-R

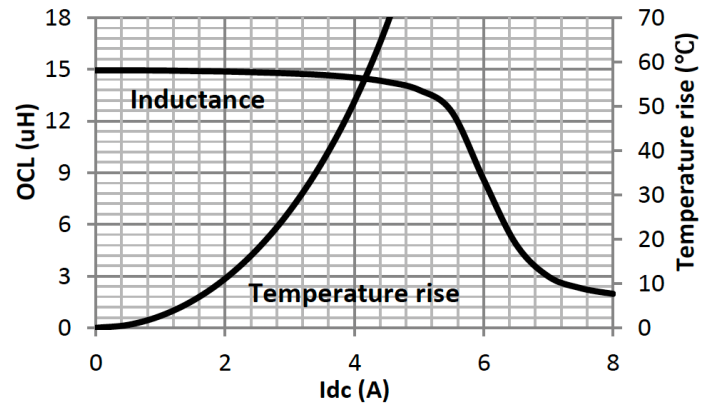

ACDL2V0910-220-R

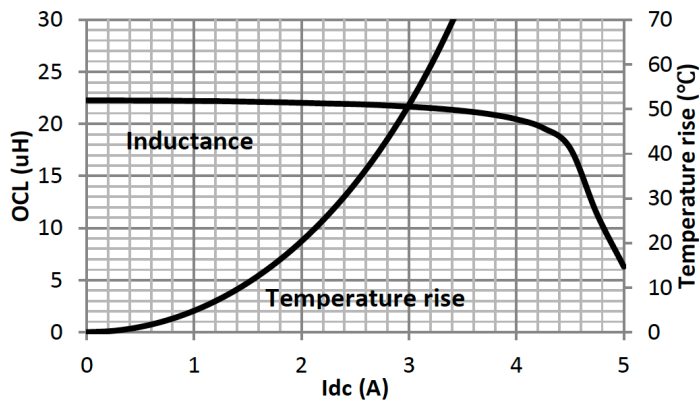

Inductance vs. Frequency

ACDL2V0910-4R7-R

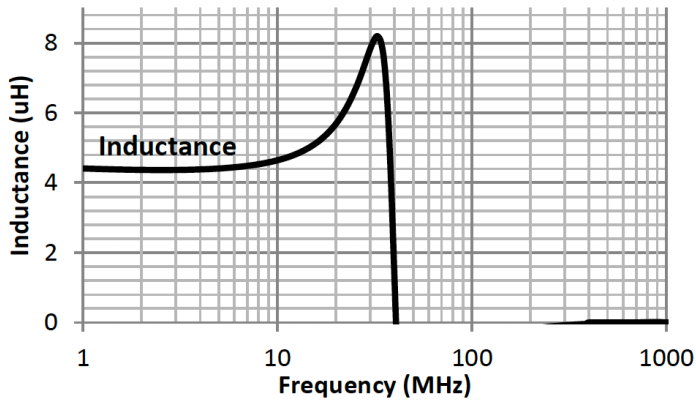

ACDL2V0910-6R8-R

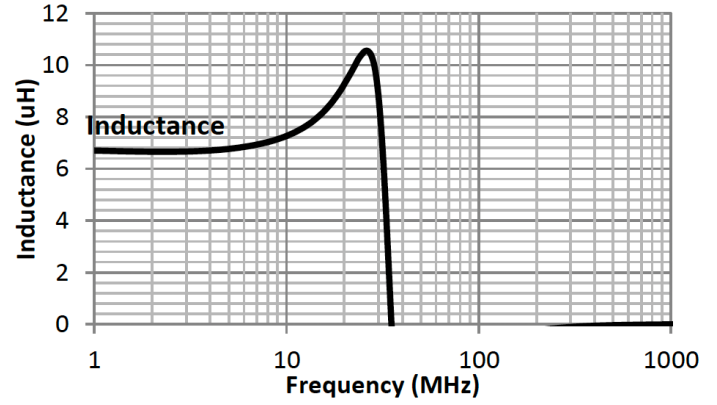

ACDL2V0910-8R2-R

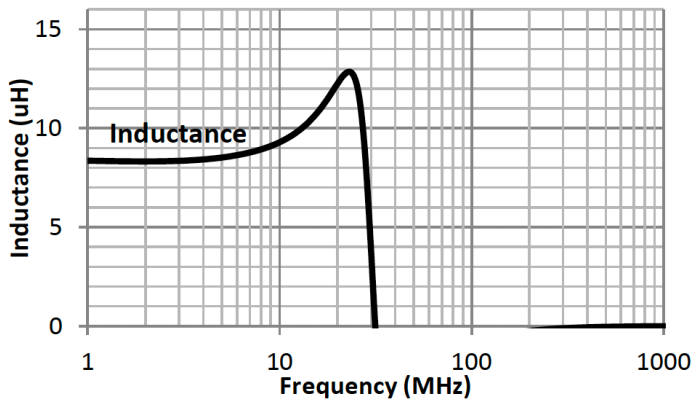

ACDL2V0910-100-R

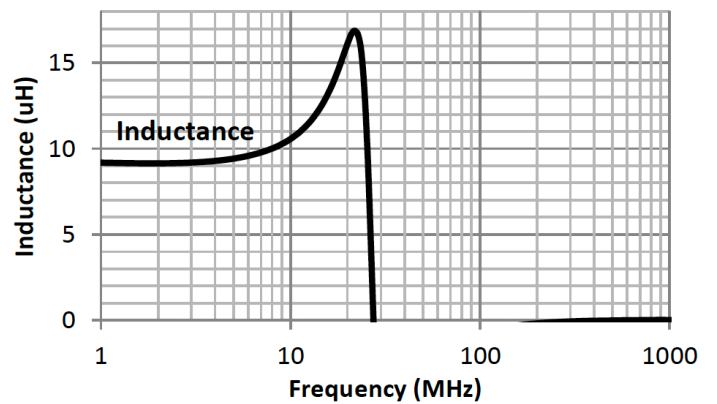

Inductance vs. Frequency, continued

ACDL2V0910-120-R

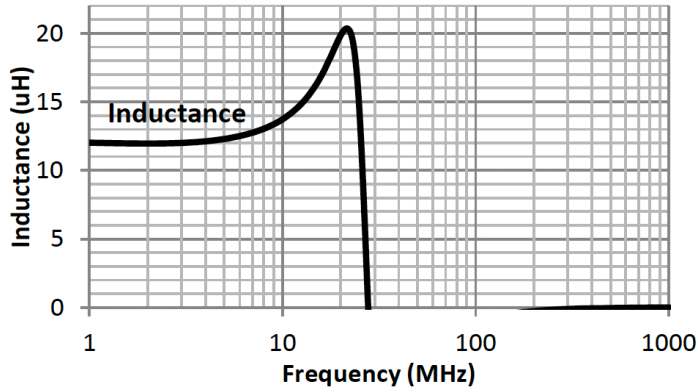

ACDL2V0910-150-R

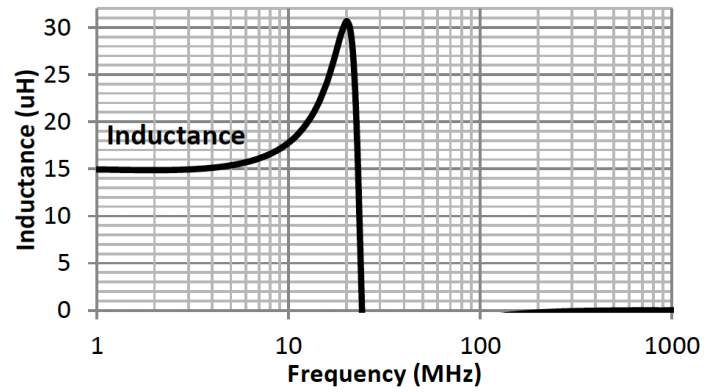

ACDL2V0910-220-R

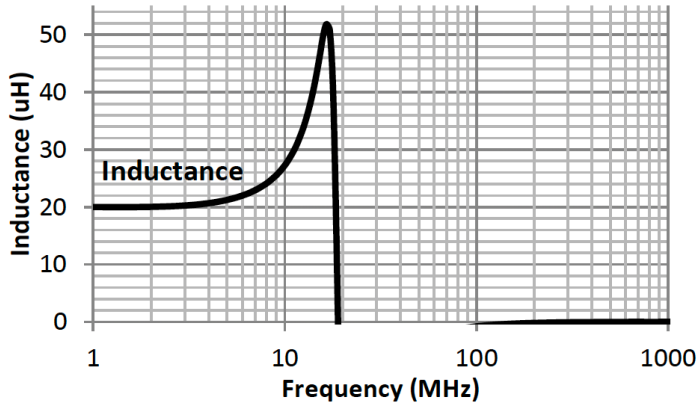

Solder reflow profile

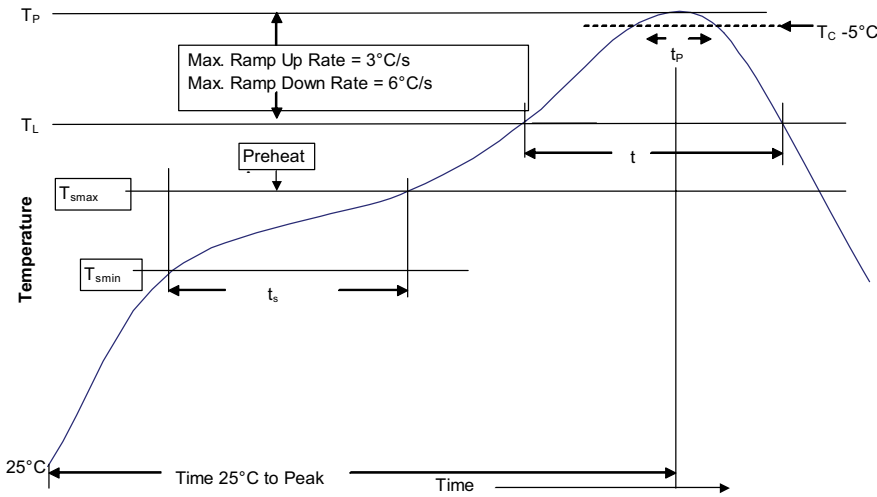

Table 1 - Standard SnPb solder (T_c)

Package thickness	Volume mm ³ <350	Volume mm ³ ≥350
<2.5 mm	235 °C	220 °C
≥2.5 mm	220 °C	220 °C

Table 2 - Lead (Pb) free solder (T_c)

Package thickness	Volume mm ³ <350	Volume mm ³ 350 - 2000	Volume mm ³ >2000
<1.6 mm	260 °C	260 °C	260 °C
1.6 – 2.5 mm	260 °C	250 °C	245 °C
>2.5 mm	250 °C	245 °C	245 °C

Reference J-STD-020

Profile feature	Standard SnPb solder	Lead (Pb) free solder
Preheat and soak		
• Temperature min. (T _{smin})	100 °C	150 °C
• Temperature max. (T _{smax})	150 °C	200 °C
• Time (T _{smin} to T _{smax}) (t _s)	60-120 seconds	60-120 seconds
Ramp up rate T _L to T _p	3 °C/ second max.	3 °C/ second max.
Liquidous temperature (T _L)	183 °C	217 °C
Time (t _L) maintained above T _L	60-150 seconds	60-150 seconds
Peak package body temperature (T _p)*	Table 1	Table 2
Time (t _p)* within 5 °C of the specified classification temperature (T _c)	20 seconds*	30 seconds*
Ramp-down rate (T _p to T _L)	6 °C/ second max.	6 °C/ second max.
Time 25 °C to peak temperature	6 minutes max.	8 minutes max.

* Tolerance for peak profile temperature (T_p) is defined as a supplier minimum and a user maximum.

Life Support Policy: Eaton does not authorize the use of any of its products for use in life support devices or systems without the express written approval of an officer of the Company. Life support systems are devices which support or sustain life, and whose failure to perform, when properly used in accordance with instructions for use provided in the labeling, can be reasonably expected to result in significant injury to the user.

Eaton reserves the right, without notice, to change design or construction of any products and to discontinue or limit distribution of any products. Eaton also reserves the right to change or update, without notice, any technical information contained in this bulletin.

Eaton
Electronics Division
1000 Eaton Boulevard
Cleveland, OH 44122
United States
Eaton.com/electronics

© 2022 Eaton
All Rights Reserved
Printed in USA
Publication No. ELX1246 BU-ELX22108
October 2022

Eaton is a registered trademark.
All other trademarks are property of their respective owners.

Follow us on social media to get the latest product and support information.

