

N/C 7362-226-1601

REVISIONS			
REV	DESCRIPTIONS	DATE	APPROVED
N/C	NEW RELEASE PER E.O.H4106	9/22/04	F.B.

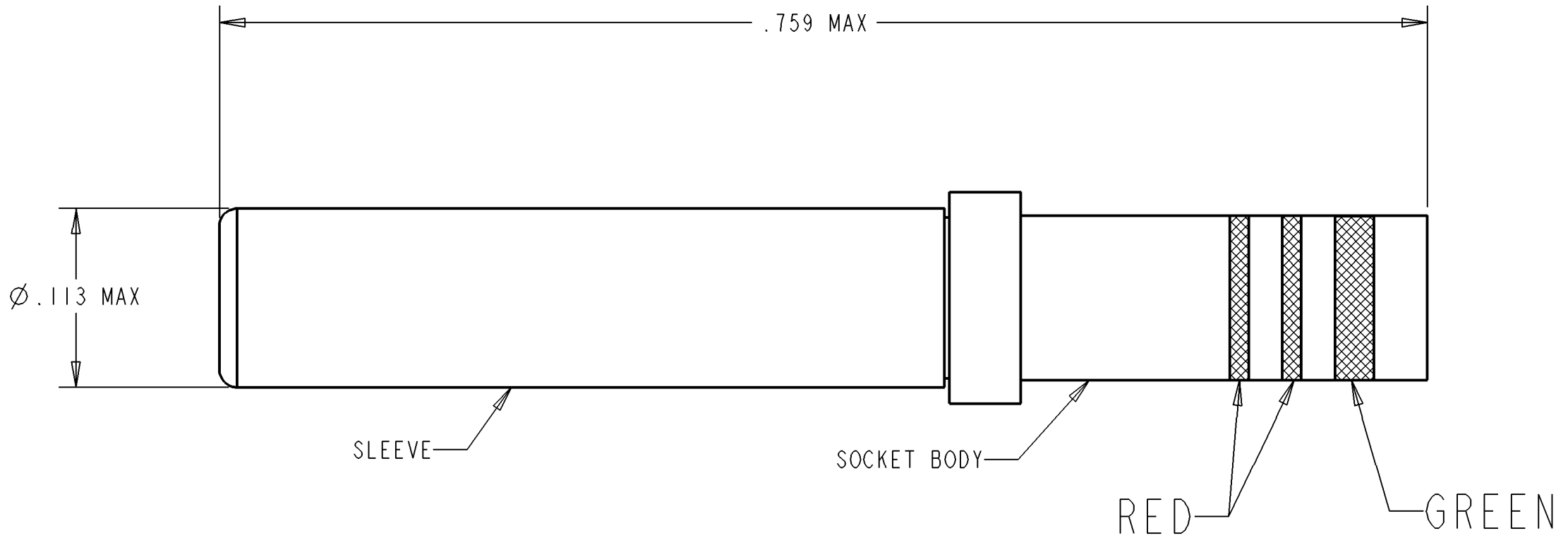

1. DIMENSIONS ARE IN INCHES UNLESS OTHERWISE SPECIFIED.
2. MATING CONTACT PIN: M39029/9-517
3. REFERENCE TOOLS:
 CRIMPING TOOL - M22520/1-01
 POSITIONER - M22520/1-02
 INSTALL/REMOVAL TOOL - M81969/14-03
4. WIRE GAGE RANGE: AWG 16 & 18
5. STRIP LENGTH: .250±.020

NOTE(S):

FILE: 7362-226-1601-ENV

UNLESS OTHERWISE SPECIFIED: DIMENSIONS ARE IN INCHES DECIMALS XXX ± .005 ANGLES ± .5° T.I.R. .010 PARTS TO HAVE NO BURRS OR SHARP EDGES	SIGNATURE & DATE	
	DR	S.LUI 9/22/04
	CHK	F.BAUTISTA 9/22/04
	MATERIAL	PE M.ALLEN 9/22/04
	FINISH	APPD M.ALLEN 9/22/04
UNPLATED		SCALE:

CONTACT, SOCKET

SIZE 16
 REMOVABLE CRIMP
 THERMOCOUPLE
 CHROMEL
 M39029/10-522

ENVELOPE

CP	MATL CODE 73
DEUTSCH ENGINEERED INTERCONNECT SOLUTIONS  250 Eddie Jones Way Oceanside, CA 92054	
B	7362-226-1601
DWG SIZE	CAGE CODE 11139 SHEET 1 OF 1