

## REGULATORY COMPLIANCE



## ITEM DESCRIPTION

Quartz Crystal Clock Oscillators XO (SPXO) LVCMOS (CMOS) 3.3Vdc 4 Pad 3.2mm x 5.0mm Ceramic Surface Mount (SMD)

## ELECTRICAL SPECIFICATIONS

<b>Nominal Frequency</b>	1MHz to 170MHz
<b>Frequency Tolerance/Stability</b>	Inclusive of all conditions: Calibration Tolerance at 25°C, Frequency Stability over the Operating Temperature Range, Supply Voltage Change, Output Load Change, First Year Aging at 25°C, Shock, and Vibration ±100ppm Maximum ±20ppm Maximum ±25ppm Maximum ±50ppm Maximum
<b>Operating Temperature Range</b>	-10°C to +70°C -40°C to +85°C
<b>Supply Voltage</b>	3.3Vdc ±10%
<b>Input Current</b>	8mA Maximum over Nominal Frequency of 1MHz to 9.999999MHz 10mA Maximum over Nominal Frequency of 10MHz to 34.999999MHz 25mA Maximum over Nominal Frequency of 35MHz to 49.999999MHz 35mA Maximum over Nominal Frequency of 50MHz to 70MHz 40mA Maximum over Nominal Frequency of 70.000001MHz to 125MHz 50mA Maximum over Nominal Frequency of 125.000001MHz to 170MHz
<b>Output Voltage Logic High (V<sub>OH</sub>)</b>	IOH = -4mA 90% of Vdd Minimum
<b>Output Voltage Logic Low (V<sub>OL</sub>)</b>	IOL = +4mA 10% of Vdd Maximum
<b>Rise/Fall Time</b>	Measured at 20% to 80% of waveform 6nSec Maximum over Nominal Frequency of 1MHz to 39.999999MHz 4nSec Maximum over Nominal Frequency of 40MHz to 79.999999MHz 3nSec Maximum over Nominal Frequency of 80MHz to 100MHz 2nSec Maximum over Nominal Frequency of 100.000001MHz to 170MHz
<b>Duty Cycle</b>	Measured at 50% of waveform 50 ±10(%) 50 ±5(%)
<b>Load Drive Capability</b>	15pF Maximum
<b>Output Logic Type</b>	CMOS
<b>Pin 1 Connection</b>	Tri-State (High Impedance)
<b>Tri-State Input Voltage (V<sub>IH</sub> and V<sub>IL</sub>)</b>	90% of Vdd Minimum or No Connect to Enable Output, 10% of Vdd Maximum to Disable Output (High Impedance)
<b>Standby Current</b>	Disabled Output: High Impedance 10µA Maximum
<b>RMS Phase Jitter</b>	12kHz to 20MHz offset frequency 1pSec Maximum
<b>Start Up Time</b>	10mSec Maximum
<b>Storage Temperature Range</b>	-55°C to +125°C

**PART NUMBERING GUIDE**

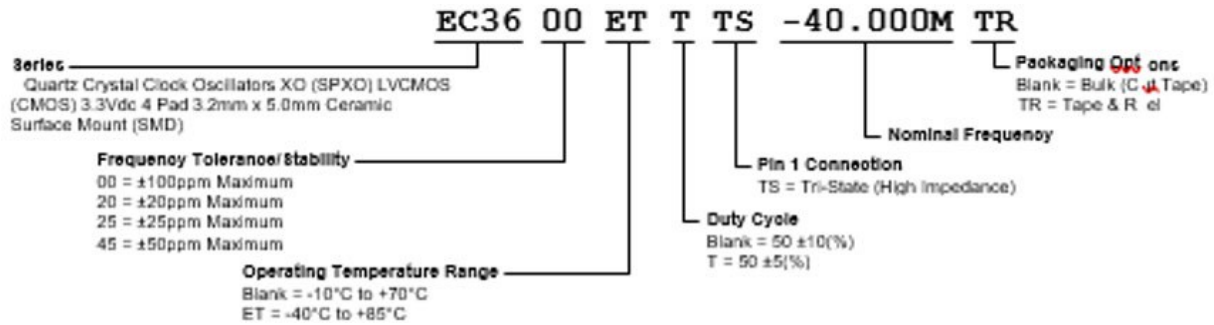

**MECHANICAL DIMENSIONS**

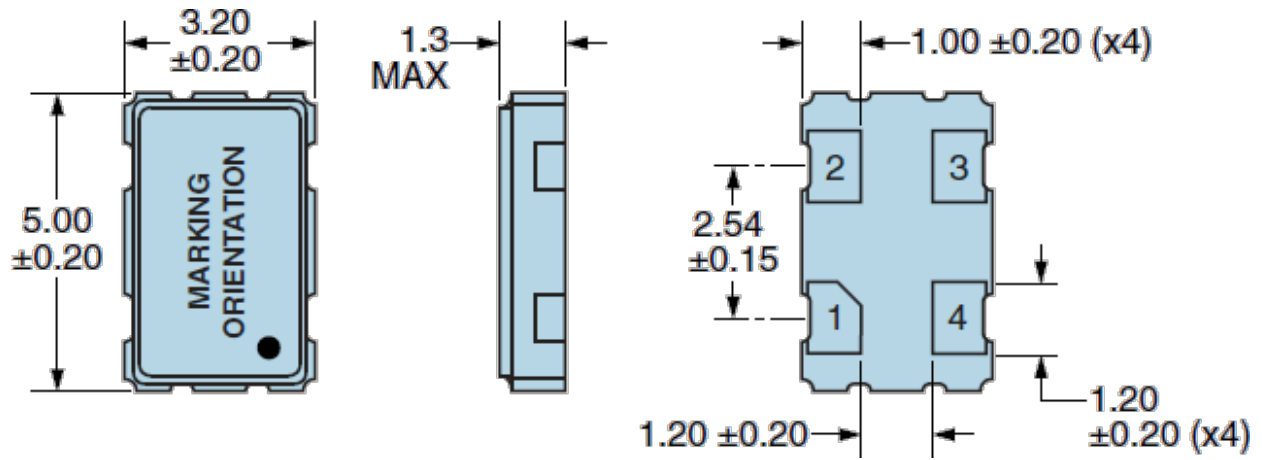

**SUGGESTED SOLDER PAD LAYOUT**

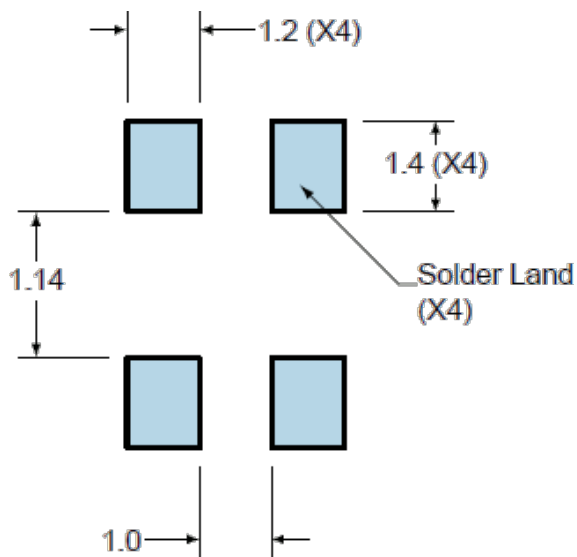

PIN	CONNECTION
1	Tri-State
2	Ground
3	Output
4	Supply Voltage

All Tolerances are ±0.1

**All Dimensions in Millimeters**

OUTPUT WAVEFORM & TIMING DIAGRAM

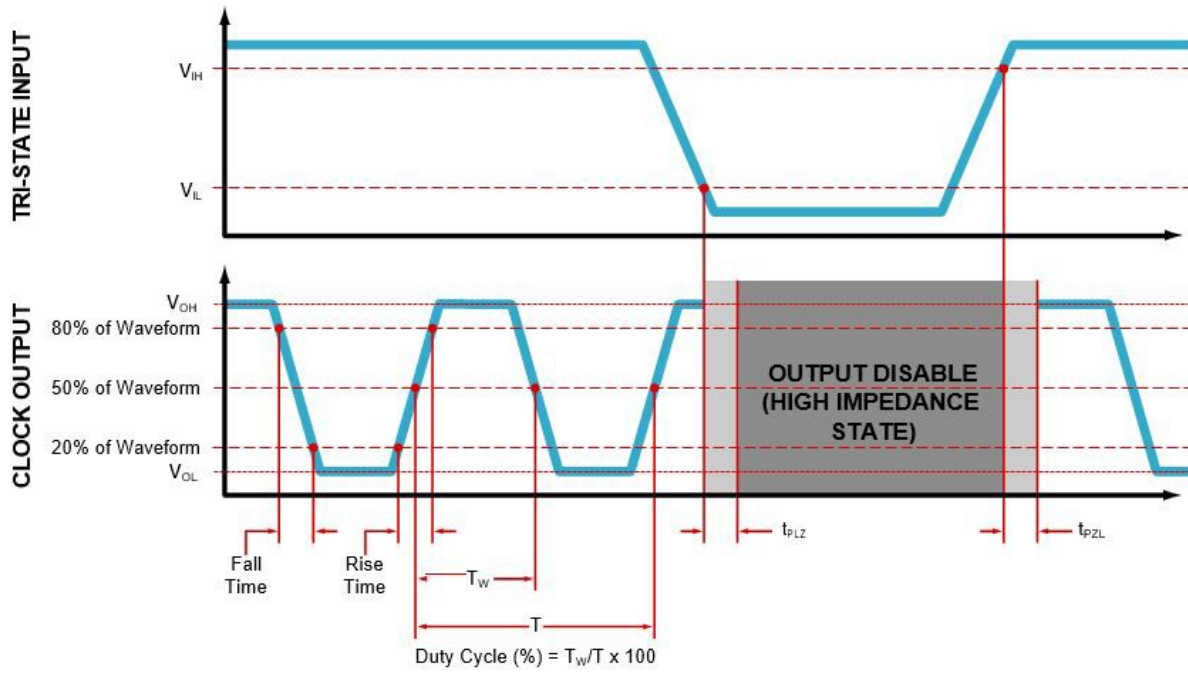

TEST CIRCUIT FOR CMOS OUTPUT

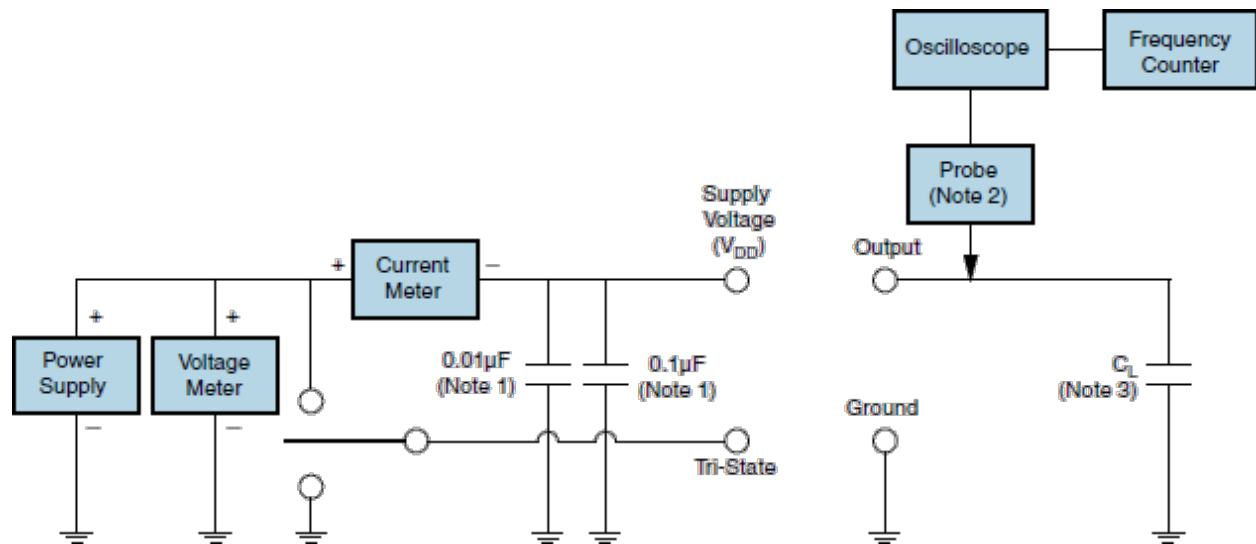

- Note 1:** An external  $0.1\mu\text{F}$  low frequency tantalum bypass capacitor in parallel with a  $0.01\mu\text{F}$  high frequency ceramic bypass Capacitor close to the package ground and supply voltage pin is required.
- Note 2:** A low input capacitance ( $<12\text{pF}$ ), 10X Attenuation Factor, High Impedance ( $>10\text{Mohms}$ ), and High bandwidth ( $>300\text{MHz}$ ) Passive probe is recommended.
- Note 3:** Capacitance value ( $C_L$ ) includes sum of all probe and fixture capacitance. See applicable specification sheet for 'Load Drive Capability'.

**TAPE & REEL DIMENSIONS**

Quantity per Reel: 1000 Units

All Dimensions in Millimeters

Compliant to EIA-481

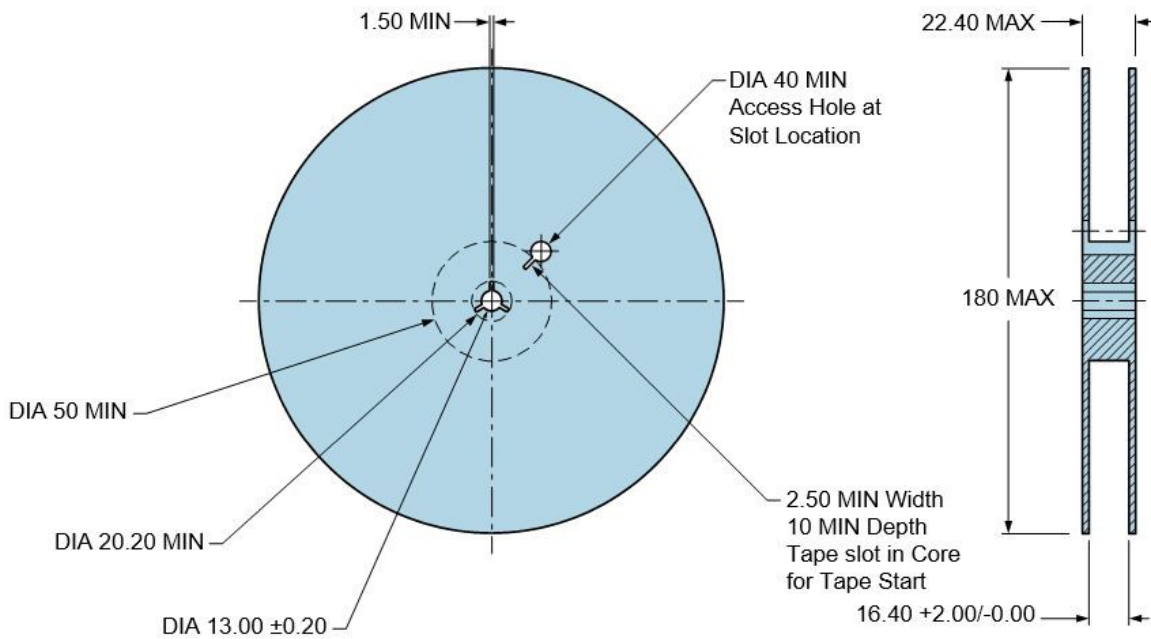
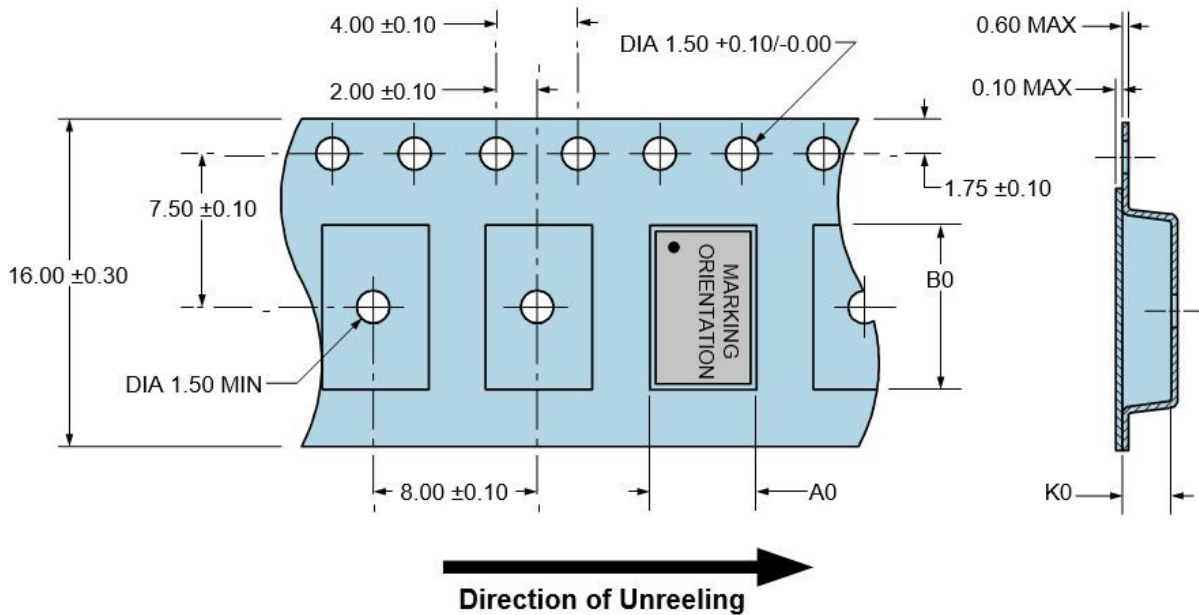

RECOMMENDED SOLDER REFLOW METHOD

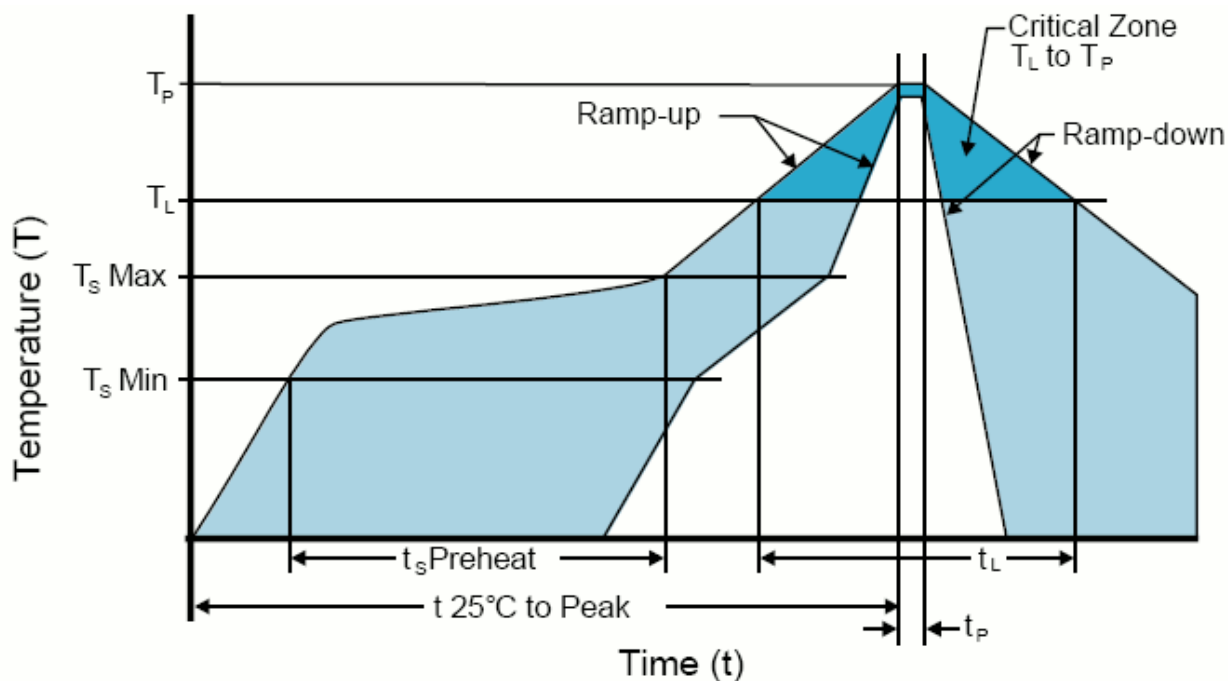

HIGH TEMPERATURE INFRARED/CONVECTION	
T <sub>s</sub> MAX to T <sub>L</sub> (Ramp-up Rate)	3°C/Second Maximum
<b>Preheat</b>	
- Temperature Minimum (T <sub>s</sub> MIN)	150°C
- Temperature Typical (T <sub>s</sub> TYP)	175°C
- Temperature Maximum(T <sub>s</sub> MAX)	200°C
- Time (t <sub>s</sub> )	60 - 180 Seconds
Ramp-up Rate (T <sub>L</sub> to T <sub>p</sub> )	3°C/Second Maximum
<b>Time Maintained Above:</b>	
- Temperature (T <sub>L</sub> )	217°C
- Time (t <sub>L</sub> )	60 - 150 Seconds
Peak Temperature (T <sub>p</sub> )	260°C Maximum for 10 Seconds Maximum
Target Peak Temperature(T <sub>p</sub> Target)	250°C +0/-5°C
Time within 5°C of actual peak (t <sub>p</sub> )	20 - 40 Seconds
Ramp-down Rate	6°C/Second Maximum
Time 25°C to Peak Temperature (t)	8 Minutes Maximum
Moisture Sensitivity Level	Level 1
Additional Notes	Temperatures shown are applied to body of device.

High Temperature Manual Soldering

260°C Maximum for 5 Seconds Maximum, 2 times Maximum. (Temperatures shown are applied to body of device.)

RECOMMENDED SOLDER REFLOW METHOD

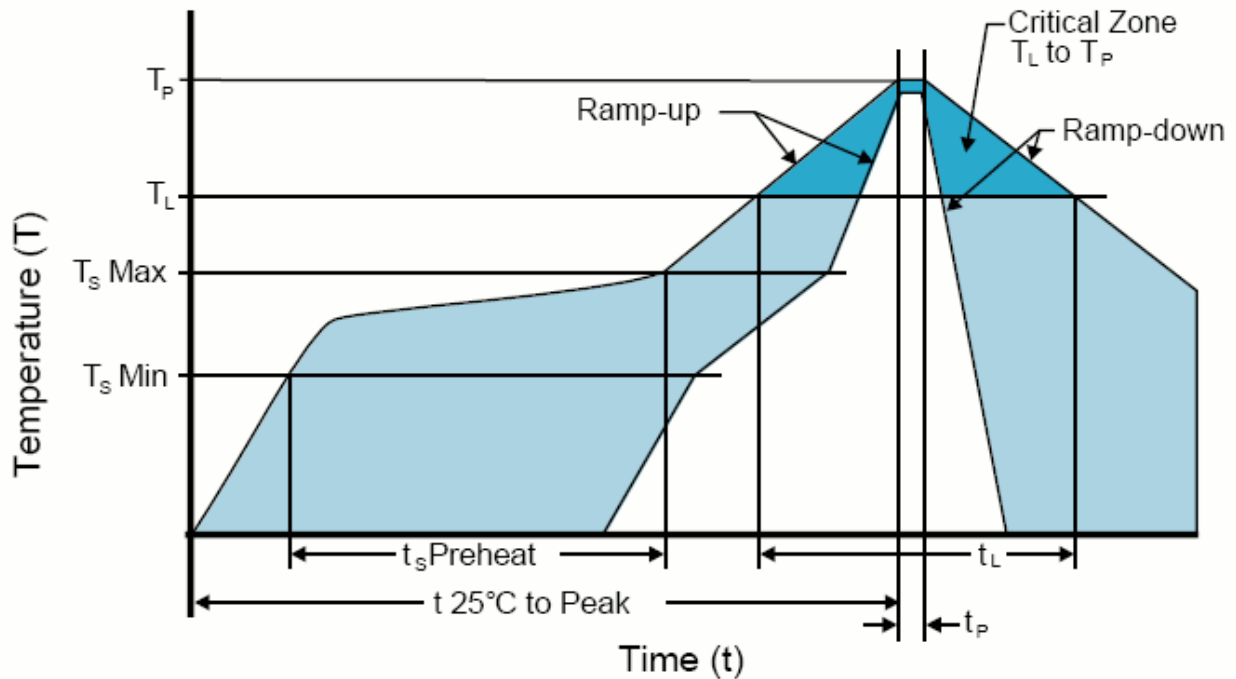

LOW TEMPERATURE INFRARED/CONVECTION	
T <sub>s</sub> MAX to T <sub>L</sub> (Ramp-up Rate)	5°C/Second Maximum
<b>Preheat</b>	
- Temperature Minimum (T <sub>s</sub> MIN)	N/A
- Temperature Typical (T <sub>s</sub> TYP)	150°C
- Temperature Maximum(T <sub>s</sub> MAX)	N/A
- Time (t <sub>s</sub> )	60 - 120 Seconds
Ramp-up Rate (T <sub>L</sub> to T <sub>P</sub> )	5°C/Second Maximum
<b>Time Maintained Above:</b>	
- Temperature (T <sub>L</sub> )	150°C
- Time (t <sub>L</sub> )	200 Seconds Maximum
Peak Temperature (T <sub>P</sub> )	240°C Maximum
Target Peak Temperature (T <sub>P</sub> Target)	240°C Maximum 2 Times / 230°C Maximum 1 Time
Time within 5°C of actual peak (t <sub>p</sub> )	10 Seconds Maximum 2 Times / 80 Seconds Maximum 1 Time
Ramp-down Rate	5°C/Second Maximum
Time 25°C to Peak Temperature (t)	N/A
Moisture Sensitivity Level	Level 1
Additional Notes	Temperatures shown are applied to body of device.

Low Temperature Manual Soldering

185°C Maximum for 10 Seconds Maximum, 2 times Maximum. (Temperatures shown are applied to body of device.)