



PI6C1288-01

Precision Clock Generator

Features

- Multiple Clock Outputs

Crystal Frequency Input MHz	CLK output	Precision Frequency Generated MHz
11.52	CLK1	40.32
	CLK2	18.432
17.28	CLK1	60.48
	CLK2	27.648

- Low jitter
- 45/55 % duty cycle
- VCC= 5.0V +/- 10 %
- Packages available
 - 16-pin 209 mil wide SSOP package (H16)
For rack mounted modems.
 - 16-pin 173 mil wide TSSOP package (L16)
For PCMCIA modems

Description

The PI6C1288-01 is a Precision Clock Generator which provides 2 clock outputs for modem applications. It utilizes a rugged, low cost 11.52 MHz or 17.28 MHz crystal to generate all required frequencies.

Function Block Diagram

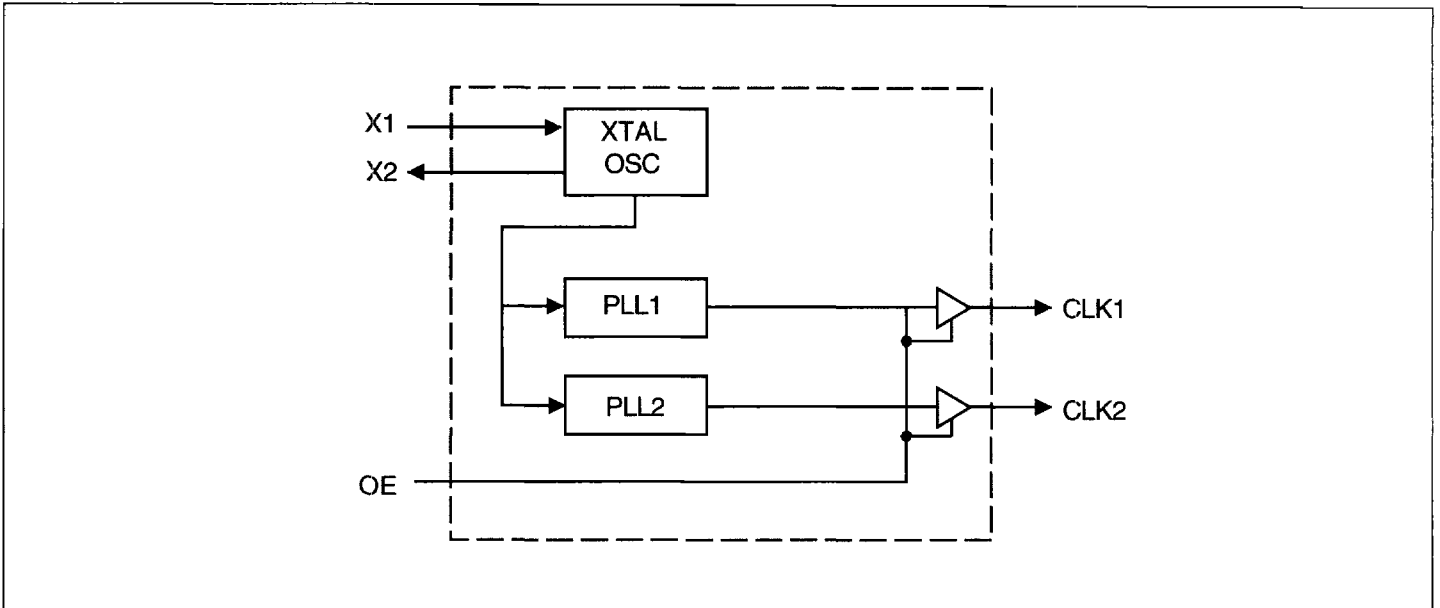

PERIS004x

Product Pin Configuration

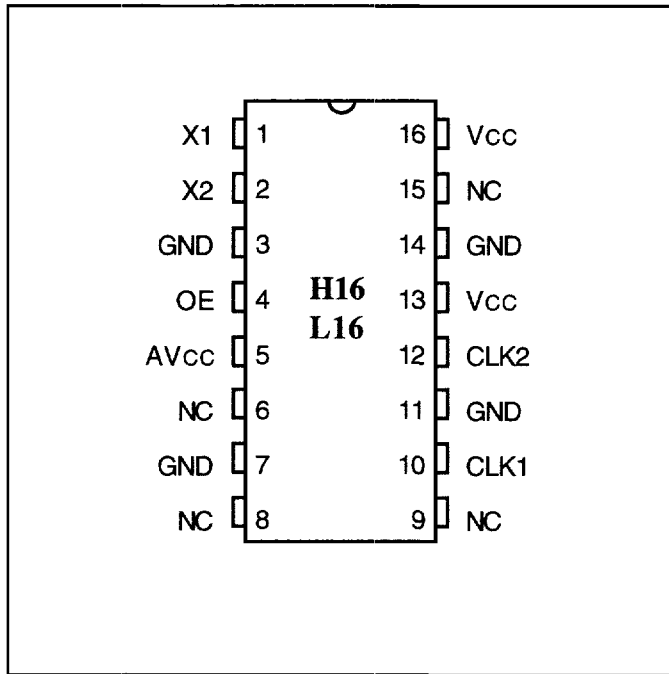

Product Pin Descriptions

Pin Name	I/O	Description
X1	I	Crystal or clock in, 11.52 MHz or 17.28 MHz
X2	O	Crystal or no connect
OE	I	Output Enable, with internal pull up = 1: Enable CLK1,2 ; = 0: Disable CLK1,2
CLK1	O	Clock output, 40.32 MHz if Xtal = 11.52; or 60.48 MHz if Xtal = 17.28 MHz.
CLK2	O	Clock output, 18.432 MHz if Xtal = 11.52; or 27.648 MHz if Xtal = 17.28 MHz.
Vcc		Digital power
AVCC		Analog power
GND		Ground

Maximum Ratings

(Above which the useful life may be impaired. For user guidelines, not tested.)

Storage Temperature	-65°C to +150°C
Ambient Temperature with Power Applied	0°C to +70°C
Supply Voltage to Ground Potential	-0.5V to +7.0V
DC Input Voltage	-0.5V to +7.0V
DC Output Current	120 mA
Power Dissipation	0.5W

Note:

Stresses greater than those listed under MAXIMUM RATINGS may cause permanent damage to the device. This is a stress rating only and functional operation of the device at these or any other conditions above those indicated in the operational sections of this specification is not implied. Exposure to absolute maximum rating conditions for extended periods may affect reliability.

DC Electrical Characteristics (Operating Range, VCC = +5.0V ±10%, Temperature 0°C to +70°C)

Parameters	Description	Condition	Min	Typ	Max	Unit
VOL	Output Low Voltage	IOL = 12.0 mA			0.45	Volt
VOH	Output High Voltage	IOH = -12.0 mA	VCC - 0.45			Volt
ICC	Power supply current	CLK1, CLK2, enabled		45		mA

AC Electrical Characteristics⁽¹⁾ (Operating Range, VCC = 5.0V ±10%, Temperature 0°C to 70°C)

Parameters	Description	Condition	Min	Typ	Max	Unit
$\Delta F^{(2)}$	Frequency tolerance			100		ppm
DutyCy	Duty cycle	CLK1, CLK2	45		55	%
Tr,Tf	Rise/Fall time	20% and 80% of Vcc			4	ns
JT ⁽³⁾	Jitter (peak to peak)	as compared to clock periods		250		ps

Notes:

1. All AC tests are performed with the following load conditions: CLK1 = 20 pF, CLK2 = 20 pF,
2. Output Frequency Stability is solely determined by crystal oscillator frequency shift.
3. Guaranteed by design, but not tested

Specification of Crystals

(Note: It is a responsibility of customer to procure the prototype and production crystals directly from crystal vendors).

Characteristic (note)	Value
Frequency, F	11.520000 MHz nom, or 17.280000 MHz nom
Frequency Tolerance at 25° C	+/- 50 ppm
Frequency Stability vs. Temperature vs. Aging	+/- 35 ppm (0°C to 70°C) +/- 15 ppm/4 years
Oscillation Mode	Fundamental
Calibration Mode	Parallel resonant
Load Capacitance, CL	20 pF
Shunt Capacitance, Co	7 pF max.
Series Resistance, R1	60 Ω max @ 100uW drive level
Drive Level	100 uW correlation 500 uW max
Operating Temperature	0° to 70° C
Storage Temperature	-40° to 85° C
Mechanical dimensions (L x W x H)	11.05 x 5.00x 5.08 mm
Holder -- Through Hole	HC-49/S (low profile)
Insulation Pad	Required

Note: Characteristics @ 25° C unless otherwise noted.

Application/Layout Information:

- (a) Locate the crystal as close to the X1 and X2 pins as possible.
- (b) Connect a 33pF capacitor between X1 and ground with short traces.
- (c) Connect a 22pF capacitor between X2 and ground with short traces.
- (d) Connect a 0.1 uF bypass capacitor between pin 13 (VCC) and ground.
- (e) Connect a 0.1 uF bypass capacitor between pin 5 (AVCC) and ground.

If Vcc is noisy, the following circuit can provide a clean AVCC to pin 5: A 2-ohm resistor and a 0.1uF bypass capacitor, with short traces:

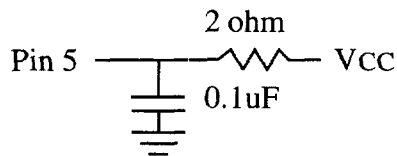

- (f) If EMI is a concern, place a 33-ohm series resistor, for CLK1 and CLK2:

33 ohm (close to Pin 10)



33 ohm (close to Pin 12)

