

PSR-M-TBUS1-SC - Extension module



1105095

<https://www.phoenixcontact.com/us/products/1105095>

Please be informed that the data shown in this PDF document is generated from our online catalog. Please find the complete data in the user documentation. Our general terms of use for downloads are valid.



Safe extension module for local bus extension, 1 function channel; TBUS interface, up to SIL 3, Cat. 4/PL e, plug-in screw terminal block, TBUS connector included

Product description

The configurable and individually scalable PSRmodular safety system is a flexible safety solution for monitoring your machine or system. The extension module is for extending the local bus in the PSRmodular system. Therefore, additional extension modules can be integrated into the system that are at a certain distance from the base station.

Your advantages

- Cost-effective safety solution with a high level of adaptability to individual requirements
- Fast startup, thanks to easy hardware and software configuration
- Machine downtimes minimized with comprehensive, easy-to-understand diagnostics
- Narrow housing width of just 22.6 mm

Commercial data

Item number	1105095
Packing unit	1 pc
Minimum order quantity	1 pc
Sales key	DN02
Product key	DNA362
GTIN	4055626973456
Weight per piece (including packing)	150 g
Weight per piece (excluding packing)	116 g
Customs tariff number	85371098
Country of origin	IT

PSR-M-TBUS1-SC - Extension module



1105095

<https://www.phoenixcontact.com/us/products/1105095>

Technical data

Product properties

Product type	Extension module
Application	Local bus extension

Insulation characteristics

Protection class	III (EN 50178)
------------------	----------------

Electrical properties

Maximum power dissipation for nominal condition	0.5 W
Nominal operating mode	100% operating factor
Interfaces	DIN rail TBUS for connection to the master module, supplied as standard

Air clearances and creepage distances between the power circuits

Rated insulation voltage	250 V AC
Rated surge voltage/insulation	Basic insulation 4 kV between all current paths and housing

Brake to be connected

Connection method	Screw connection
-------------------	------------------

Supply

Designation	A1/A2
Rated control circuit supply voltage U_S	19.2 V DC ... 28.8 V DC
Rated control circuit supply voltage U_S	24 V DC -20 % / +20 % (provide external protection, typically 1 A)
Rated control supply current I_S	typ. 21 mA (at U_S)
Power consumption at U_S	typ. 0.5 W
Inrush current	max. 8 A ($\Delta t = 200 \mu s$ at U_S)
Filter time	typ. 20 ms (in the event of voltage dips at U_S)
Protective circuit	Serial protection against polarity reversal Varistor

Connection data

Connection method	Screw connection
Stripping length	7 mm
Tightening torque	0.5 ... 0.6 Nm
Screw thread	M3

Interfaces

Data: Local bus extension

Communication protocol	RS-485
Connection method	Terminal block
Number of connections	1

PSR-M-TBUS1-SC - Extension module



1105095

<https://www.phoenixcontact.com/us/products/1105095>

Note	Note the requirements for the transmission cable in accordance with the data sheet section "Wiring".
------	--

Signaling

Status display	1 x green LED
Operating voltage display	1 x green LED
Error indication	2 x LED (red)

Dimensions

Width	22.61 mm
Height	112.58 mm
Depth	113.6 mm

Material specifications

Color (Housing)	yellow (RAL 1018)
Housing material	Polyamide PA non-reinforced

Environmental and real-life conditions

Ambient conditions

Degree of protection	IP20
Min. degree of protection of inst. location	IP54
Ambient temperature (operation)	-10 °C ... 55 °C (observe derating)
Ambient temperature (storage/transport)	-20 °C ... 85 °C
Maximum altitude	≤ 2000 m (Above sea level)
Max. permissible humidity (storage/transport)	95 % (non-condensing)
Max. permissible relative humidity (operation)	95 % (non-condensing)
Shock	10g for $\Delta t = 16$ ms (continuous shock, 1000 shocks in each space direction)
Vibration (operation)	10 Hz ... 150 Hz, 2g

Approvals

CE

Identification	CE-compliant
----------------	--------------

Mounting

Mounting type	DIN rail mounting
Mounting position	vertical or horizontal
Connection method	Screw connection

PSR-M-TBUS1-SC - Extension module



1105095

<https://www.phoenixcontact.com/us/products/1105095>

Drawings

Application drawing

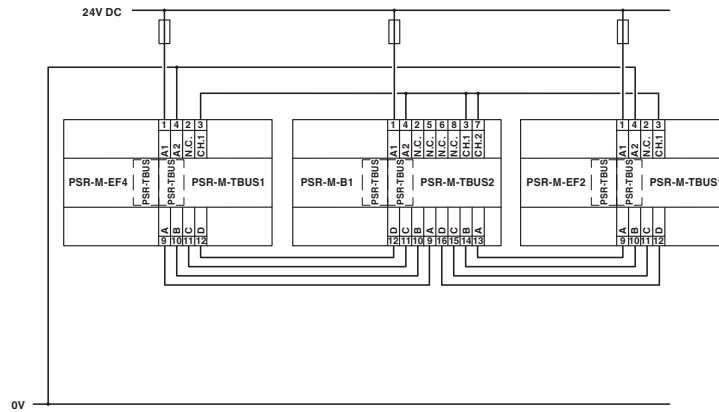

Block diagram

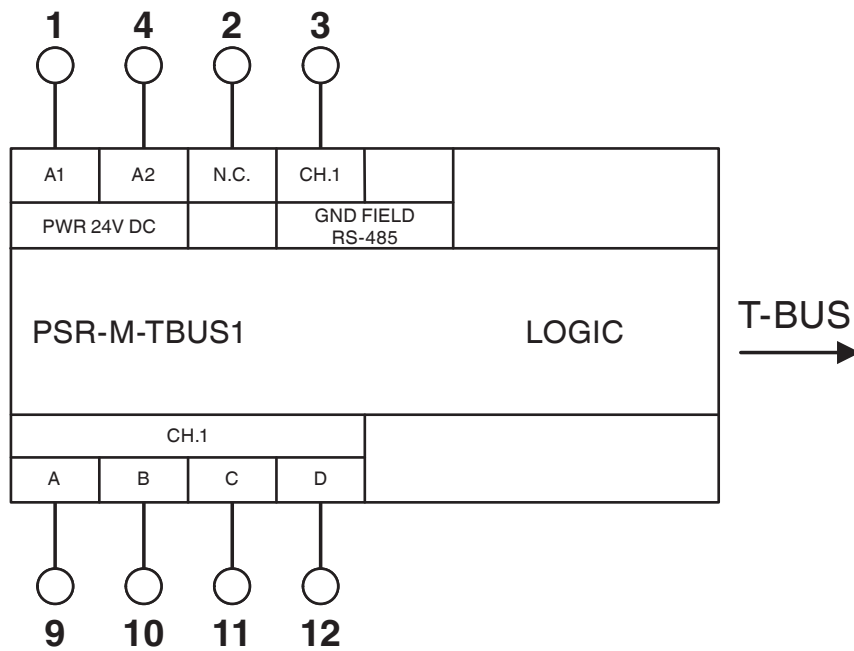

Block diagram

PSR-M-TBUS1-SC - Extension module



1105095

<https://www.phoenixcontact.com/us/products/1105095>

Approvals

🔗 To download certificates, visit the product detail page: <https://www.phoenixcontact.com/us/products/1105095>



UL Listed

Approval ID: FILE E 238705



cUL Listed

Approval ID: FILE E 238705



EAC

Approval ID: RU*-DE*B.00606/20



Functional Safety

Approval ID: Z10 029429 0013

cULus Listed

PSR-M-TBUS1-SC - Extension module



1105095

<https://www.phoenixcontact.com/us/products/1105095>

Classifications

ECLASS

ECLASS-11.0	27371819
ECLASS-13.0	27371819
ECLASS-12.0	27371819

ETIM

ETIM 9.0	EC001449
----------	----------

UNSPSC

UNSPSC 21.0	39122200
-------------	----------

PSR-M-TBUS1-SC - Extension module



1105095

<https://www.phoenixcontact.com/us/products/1105095>

Environmental product compliance

China RoHS	Environmentally friendly use period: unlimited = EFUP-e
	No hazardous substances above threshold values

PSR-M-TBUS1-SC - Extension module



1105095

<https://www.phoenixcontact.com/us/products/1105095>

Accessories

CP-MSTB - Coding profile

1734634

<https://www.phoenixcontact.com/us/products/1734634>

Coding profile, is inserted into the slot on the plug or inverted header, red insulating material



CR-MSTB - Coding section

1734401

<https://www.phoenixcontact.com/us/products/1734401>

Coding section, inserted into the recess in the header or the inverted plug, red insulating material



PSR-M-TBUS1-SC - Extension module



1105095

<https://www.phoenixcontact.com/us/products/1105095>

PSR-M-CABLE50 - Cable

1104841

<https://www.phoenixcontact.com/us/products/1104841>

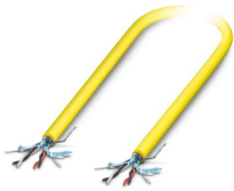

Connection cable for TBUS extension in connection with PSR-M-TBUS1 or PSR-M-TBUS2, 50 m

PSR-M-CABLE25 - Cable

1104855

<https://www.phoenixcontact.com/us/products/1104855>

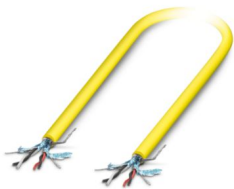

Connection cable for TBUS extension in connection with PSR-M-TBUS1 or PSR-M-TBUS2, 25 m

Phoenix Contact 2024 © - all rights reserved
<https://www.phoenixcontact.com>

Phoenix Contact USA
586 Fulling Mill Road
Middletown, PA 17057, United States
(+717) 944-1300
info@phoenixcon.com