



LC²MOS Octal 8-Bit D/A Converter

AD7228

1.1 Scope.

This specification covers the detail requirements for an octal CMOS digital-to-analog converter.

1.2 Part Number.

The complete part number per Table 1 of this specification is as follows:

Device	Part Number ¹
-1	AD7228T(X)/883B
-2	AD7228U(X)/883B

NOTE

¹To complete the part number substitute the package identifier as shown in paragraph 1.2.3.

1.2.3 Case Outline.

See Appendix 1 of General Specification ADI-M-1000: package outline:

(X)	Package	Description
Q	Q-24	24-Pin Cerdip, 0.3" Width
E	E-28A	28-Contact LCC

1.3 Absolute Maximum Ratings. (T_A = +25°C unless otherwise noted)

V _{DD} to GND	-0.3 V to +17 V
V _{DD} to V _{SS}	+0.3 V to +24 V
Digital Input Voltage	-0.3 V, V _{DD}
V _{REF} to GND	-0.3 V, V _{DD}
V _{OUT} to GND ¹	V _{SS} , V _{DD}
Power Dissipation		
Up to +75°C	1000 mW
Derates above +75°C	2.0 mW/°C
Operating Temperature Range	-55°C to +125°C
Thermal Resistance (θ_{JC}):		
Case 1 (Q-24)	See MIL-M-38510, Appendix C
Case 3 (E-28A)	See MIL-M-38510, Appendix C
Storage Temperature	-65°C to +125°C
Lead Temperature (Soldering 10 sec)	+300°C
Junction Temperature	+175°C

NOTE

¹Outputs may be shorted to any voltage in the range V_{SS} to V_{DD} provided that the power dissipation of the package is not exceeded. Typical short circuit for a short to V_{SS} is 50 mA.

8
DIGITAL-TO-ANALOG CONVERTERS

AD7228—SPECIFICATIONS

Table 1.

Test	Symbol	Device	Design		Sub Group	Test Condition ¹	Units	
			Min	Max				
Total Unadjusted Error ²	TUE	-1, 2	-2	+2	1	V _{DD} = 15 V ±10%, V _{REF} = +10 V (Single Supply Only)	LSB	
		-1	-2	+2	2, 3			
		-2	-1	+1	2, 3			
		-2	-1	+1	4			
Total Unadjusted Error	TUE	-1	-2	+2	13, 14, 15	Dual Supply Only	LSB	
		-2	-1	+1				
Relative Accuracy	RA	-1, 2	-1	+1	1		LSB	
		-1	-1	+1	2, 3			
		-2	-0.5	+0.5	2, 3			
		-2	-0.5	+0.5	12			
Differential Nonlinearity	DNL	-1, 2	-1	+1	1, 2, 3	Guaranteed Monotonic (Single Supply Only)	LSB	
Differential Nonlinearity	DNL	-1, 2	-1	+1	13, 14, 15	Dual Supply Only	LSB	
Full-Scale Error ³	A _E	-1, 2	-1	+1	1		mV	
		-1	-1	+1	2, 3			
		-2	-0.5	+0.5	2, 3			
		-2	-0.5	+0.5	12			
Zero Code Error	A _{ZCE}	-1, 2	-25	+25	1		mV	
		-1	-30	+30	2, 3			
		-2	-20	+20	2, 3			
		-2	-15	+15	12			
Load Resistance	R _L	-1, 2	2		1, 2, 3	V _{OUT} = ±10 V (Dual Supply & Single Supply)	kΩ	
Reference Input Voltage Range	V _{REF}	-1, 2	2	10	1, 2, 3		V	
Reference Input Resistance	R _{IN}	-1, 2	2		1, 2, 3	Dual Supply Only	kΩ	
Reference Input Capacitance ⁴	C _{IN} (REF)	-1, 2		500	13, 14, 15	Dual and Single Supply	pF	
Digital Input High Voltage	V _{INH}	-1, 2	2.4		1, 2, 3	Dual Supply Only	V	
Digital Input Low Voltage	V _{INL}	-1, 2		0.8	1, 2, 3	Input Coding Is Binary	V	
Digital Input Leakage Current	I _{ILC}	-1, 2	-1	+1	1, 2, 3		μA	
Digital Input Capacitance	C _{IN}	-1, 2		8	13, 14, 15		pF	
Voltage Output Slew Rate	SR	-1, 2	2		13, 14, 15	Dual and Single Supply	V/μs	
Voltage Output Settling Time ⁵	t _{SL}	-1, 2			13, 14, 15	Dual and Single Supply	μs	
			Positive Full-Scale Change					5
			Negative Full-Scale Change					5
		-1, 2				Dual Supply		
						Single Supply		
Power Supply Current	I _{DD}	-1, 2			1	Dual Supply Only	mA	
					22			
		-1, 2			1			
					20			
Function Tests ⁶		-1, 2			7			
Address to $\overline{\text{WR}}$ Setup Time	t ₁	-1, 2	0		9, 10, 11	Dual and Single Supply See Figure 2 and Note 7	ns	
Address to $\overline{\text{WR}}$ Hold Time	t ₂	-1, 2	0		9, 10, 11			
Data Valid to $\overline{\text{WR}}$ Setup Time	t ₃	-1, 2	70		9			
			100		10, 11			
Data Valid to $\overline{\text{WR}}$ Hold Time	t ₄	-1, 2	10		9, 10, 11		ns	

Test	Symbol	Device	Design		Sub Group	Test Condition ¹	Units
			Min	Max			
Write Pulse Width	t_s	-1, 2	95		9		ns
			150		10, 11		

NOTES

¹ -55°C < T_A < +125°C, Dual Supply unless otherwise specified. R_L = 2k, C_L = 100 pF unless otherwise stated. Parameters in subgroups

13, 14, 15 are characterized at initial design and after any subsequent redesigns.

² Includes zero code error, relative accuracy and full-scale error.

³ Calculated after zero code error has been adjusted out.

⁴ Occurs when each DAC is loaded with all 1s.

⁵ V_{REF} = +10 V; settling time to ±1/2 LSB.

⁶ Subgroup 7 tests are for the purpose of verifying the truth table.

⁷ All input rise and fall times measured from 10% to 90% of +5 V, t_R = t_F = 5 ns.

Timing measurement reference level is $\frac{V_{INH} + V_{INL}}{2}$.

1.3.1 Recommended Operating Conditions.

Operating Voltage Range for Dual Supply

Positive Supply (V_{DD}) +10.8 V to +16.5 V

Negative Supply (V_{SS}) -4.5 V to -5.5 V

Reference Voltage (V_{REF})¹ +2.0 V to +10.0 V

Operating Voltage Range for Single Supply

Positive Supply (V_{DD}) +13.5 V to +16.5 V

Negative Supply (V_{SS}) 0 V

Reference Voltage (V_{REF})¹ +10 V

NOTE

¹V_{OUT} must be less than V_{DD} by 3.5 V to ensure correct operation.

3.2.1 Functional Block Diagram and Terminal Assignments.

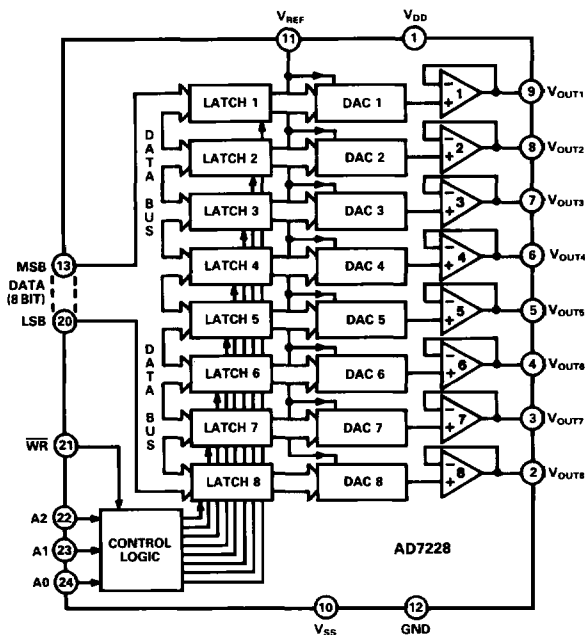

AD7228

Q Package (Cerdip)

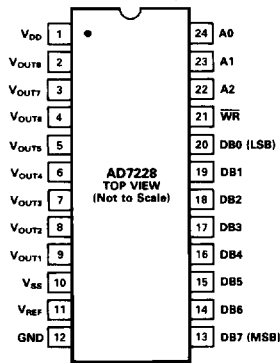

E Package (LCC)

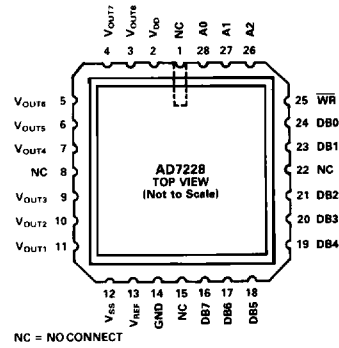

Table 2. Truth Table

AD7228 Control Inputs

\overline{WR}	A2	A1	A0	Operation
H	X	X	X	No Operation Device Not Selected
L	L	L	L	DAC 1 Transparent
L	L	L	L	DAC 1 Latched
L	L	L	H	DAC 2 Transparent
L	L	H	L	DAC 3 Transparent
L	L	H	H	DAC 4 Transparent
L	H	L	L	DAC 5 Transparent
L	H	L	H	DAC 6 Transparent
L	H	H	L	DAC 7 Transparent
L	H	H	H	DAC 8 Transparent

H = High State L = Low State X = Don't Care

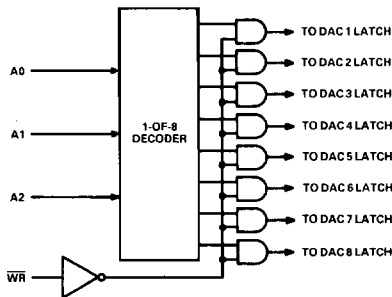
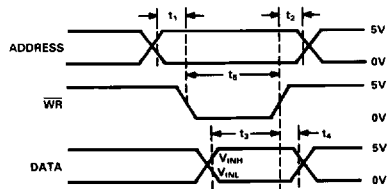

Figure 1. Input Control Logic



NOTE:
THE SELECTED INPUT LATCH IS TRANSPARENT WHILE \overline{WR} IS LOW.
THUS INVALID DATA DURING THIS TIME CAN CAUSE SPURIOUS OUTPUTS

Figure 2. Write Cycle Timing Diagram

3.2.4 Microcircuit Technology Group.

This microcircuit is covered by technology group (80).

4.2.1 Life Test/Burn-In Circuit.

Steady state life test is per MIL-STD-883 Method 1005. Burn-in is per MIL-STD-883 Method 1015 test condition (B).

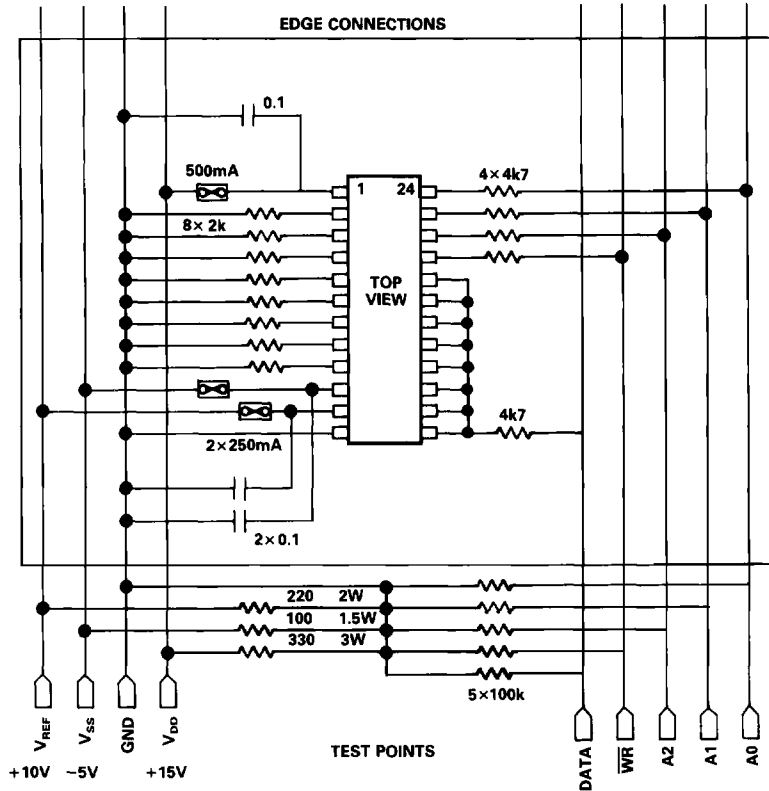

TO INITIALIZE, APPLY THE FOLLOWING WAVEFORMS:
EACH PULSE OF A0 SHOULD BE AT LEAST 50µs.

DATA = 15V

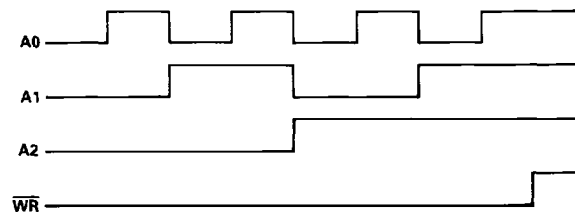

THIS SEQUENCE ENSURES ALL DACS ARE LOADED.

Burn-In Conditions