

## General Description:

The LWS6010H4 uses advanced SGT technology and design to provide excellent  $R_{DS(ON)}$  with low gate charge. It can be used in a wide variety of applications. The package form is TO-252, which accords with the ROHS standard and Halogen Free standard.

## Features:

- Fast Switching
- Low Gate Charge and  $R_{DS(ON)}$
- Low Reverse transfer capacitances

## Applications:

- Battery switching application
- Hard switched and high frequency circuits
- Power Management

**100% DVDS Tested**

**100% Avalanche Tested**



$V_{DSS}$	-60	V
$I_D$	-80	A
$P_D$	150	W
$R_{DS(ON)}$ TYPE	9.0	m $\Omega$

Marking and Pin Assignment

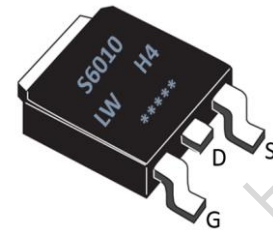

Inner Equivalent Principium Chart

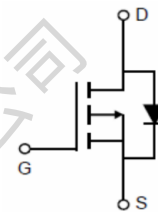

## Package Marking and Ordering Information:

Marking	Part Number	Package	Packing	Qty.
S6010/LW H4/D.C.	LWS6010H4	TO-252	Reel	2500 Pcs

## Absolute Maximum Ratings:

Symbol	Parameter	Value	Units
$V_{DSS}$	Drain-to-Source Voltage	-60	V
$I_D$	Continuous Drain Current	$T_C=25^\circ\text{C}$	-80
	Continuous Drain Current	$T_C=100^\circ\text{C}$	-50
$I_{DM}^{a1}$	Pulsed Drain Current	-320	A
$V_{GS}$	Gate-to-Source Voltage	$\pm 20$	V
$P_D$	Power Dissipation	150	W
$E_{AS}^{a2}$	Single pulse avalanche energy	450	mJ
$T_J, T_{STG}$	Operating Junction and Storage Temperature Range	150, -55 to 150	$^\circ\text{C}$
$T_L$	Maximum Temperature for Soldering	260	$^\circ\text{C}$

## Thermal Characteristics:

Symbol	Parameter	Value	Units
$R_{\theta JC}$	Thermal Resistance, Junction-to-Case	0.83	$^\circ\text{C}/\text{W}$
$R_{\theta JA}$	Thermal Resistance, Junction-to-Ambient	60	$^\circ\text{C}/\text{W}$

**Electrical Characteristic** ( $T_A = 25\text{ }^\circ\text{C}$ , unless otherwise specified):

Static Characteristics						
Symbol	Parameter	Test Conditions	Value			Units
			Min.	Typ.	Max.	
$V_{DSS}$	Drain to Source Breakdown Voltage	$V_{GS}=0V, I_D=-250\mu A$	-60	--	--	V
$I_{DSS}$	Drain to Source Leakage Current	$V_{DS}=-60V, V_{GS}=0V$	--	--	1.0	$\mu A$
$I_{GSS(F)}$	Gate to Source Forward Leakage	$V_{GS}=-20V, V_{DS}=0V$	--	--	100	nA
$I_{GSS(R)}$	Gate to Source Reverse Leakage	$V_{GS}=+20V, V_{DS}=0V$	--	--	-100	nA
$V_{GS(TH)}$	Gate Threshold Voltage	$V_{DS}=V_{GS}, I_D=-250\mu A$	-2.5	-3.0	-3.5	V
$R_{DS(ON)}$	Drain-to-Source On-Resistance	$V_{GS}=-10V, I_D=-20A$	--	9.0	11.0	m $\Omega$
$g_{FS}$	Forward Transconductance	$V_{DS}=-10V, I_D=-20A$	50	--	--	S

Dynamic Characteristics						
Symbol	Parameter	Test Conditions	Value			Units
			Min.	Typ.	Max.	
$C_{iss}$	Input Capacitance	$V_{GS} = 0V$	--	3959	--	pF
$C_{oss}$	Output Capacitance	$V_{DS} = -30V$	--	611	--	
$C_{rss}$	Reverse Transfer Capacitance	$f = 1.0MHz$	--	34	--	
$R_G$	Gate resistance	$V_{GS}=0V, V_{DS}$ Open	--	2.0	--	$\Omega$

Resistive Switching Characteristics						
Symbol	Parameter	Test Conditions	Value			Units
			Min.	Typ.	Max.	
$t_{d(ON)}$	Turn-on Delay Time	$I_D = -20A$	--	4.5	--	ns
$t_r$	Rise Time	$V_{DS} = -30V$	--	2.5	--	
$t_{d(OFF)}$	Turn-Off Delay Time	$V_{GS} = -10V$	--	14.5	--	
$t_f$	Fall Time	$R_G = 3\Omega$	--	3.5	--	
$Q_g$	Total Gate Charge	$V_{GS} = -10V$	--	47	--	nC
$Q_{gs}$	Gate Source Charge	$V_{DS} = -30V$	--	11	--	
$Q_{gd}$	Gate Drain Charge	$I_D = -20A$	--	9	--	

Source-Drain Diode Characteristics						
Symbol	Parameter	Test Conditions	Value			Units
			Min.	Typ.	Max.	
$I_S$	Diode Forward Current	$T_C = 25\text{ }^\circ\text{C}$	--	--	-80	A
$I_{SM}$	Diode Pulse Current		--	--	-320	A
$V_{SD}$	Diode Forward Voltage	$I_S = -20A, V_{GS} = 0V$	--	--	-1.2	V
$t_{rr}$	Reverse Recovery time	$I_S = -20A, V_{DD} = -30V,$	--	60	--	ns
$Q_{rr}$	Reverse Recovery Charge	$dI/dt = 100A/us$	--	105	--	nC

a1: Repetitive rating; pulse width limited by maximum junction temperature

a2:  $V_{DD} = -30V, L = 0.3mH, R_G = 25\Omega$ , Starting  $T_j = 25\text{ }^\circ\text{C}$

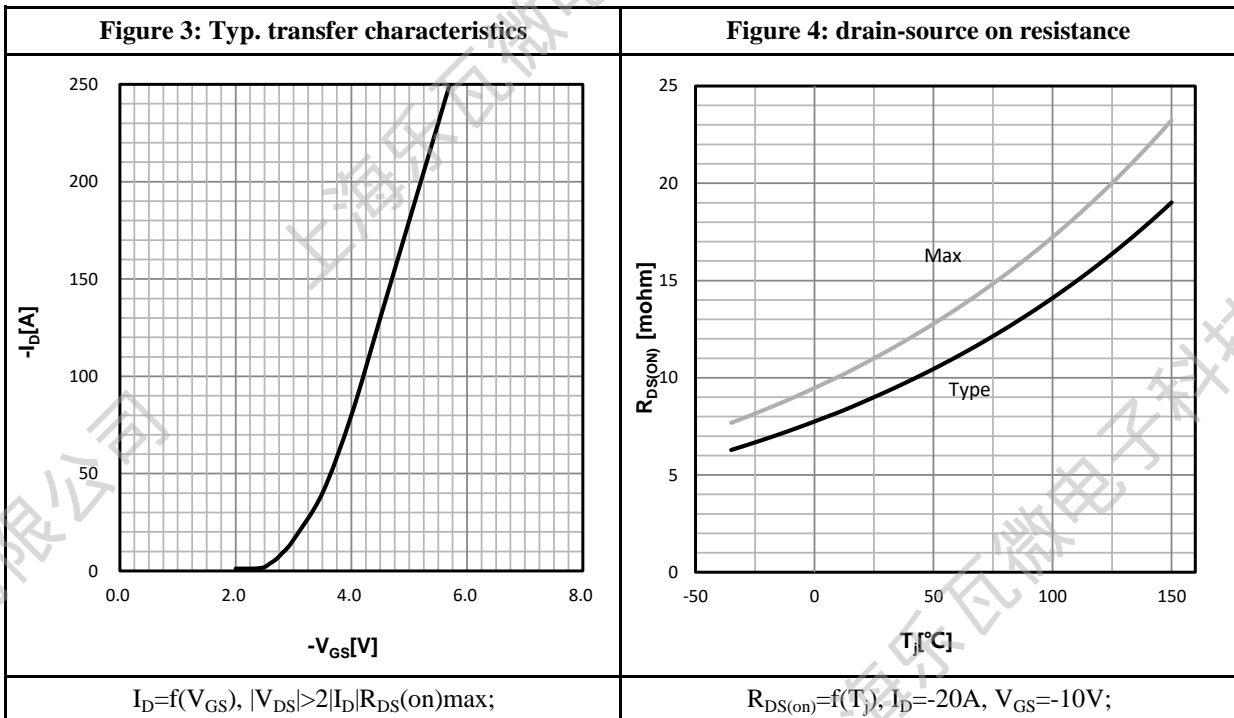
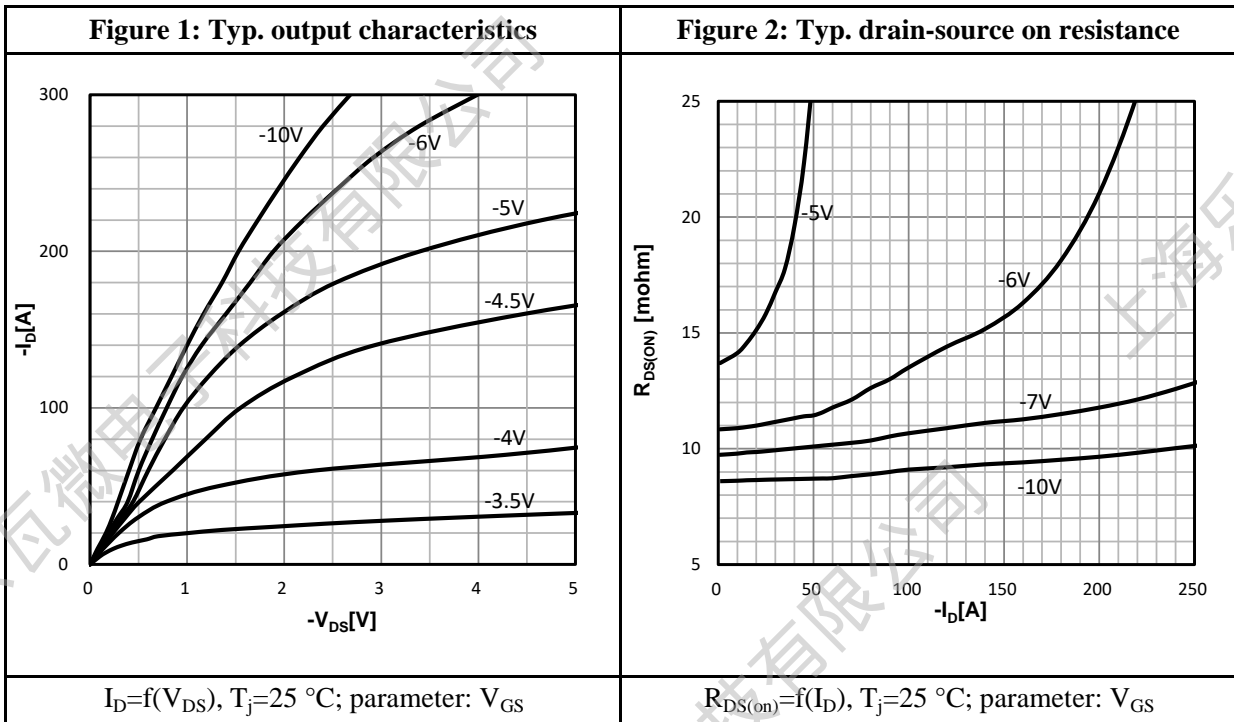
**Characteristics Curve:**

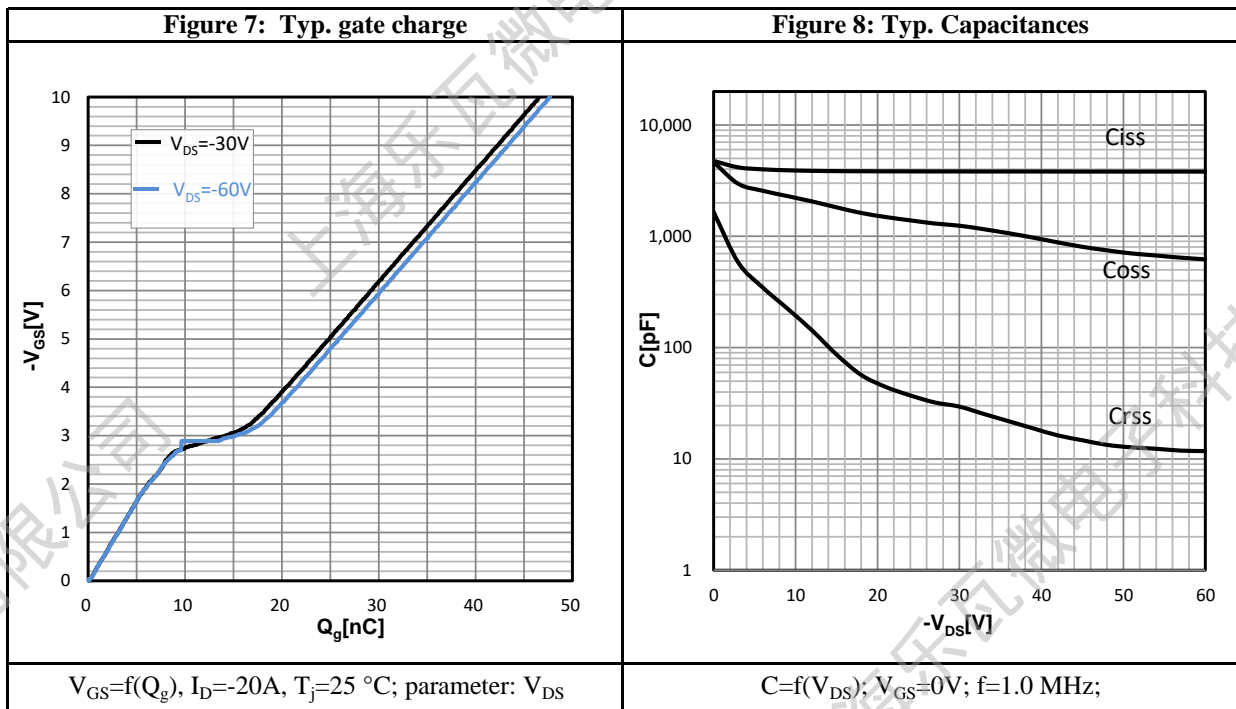
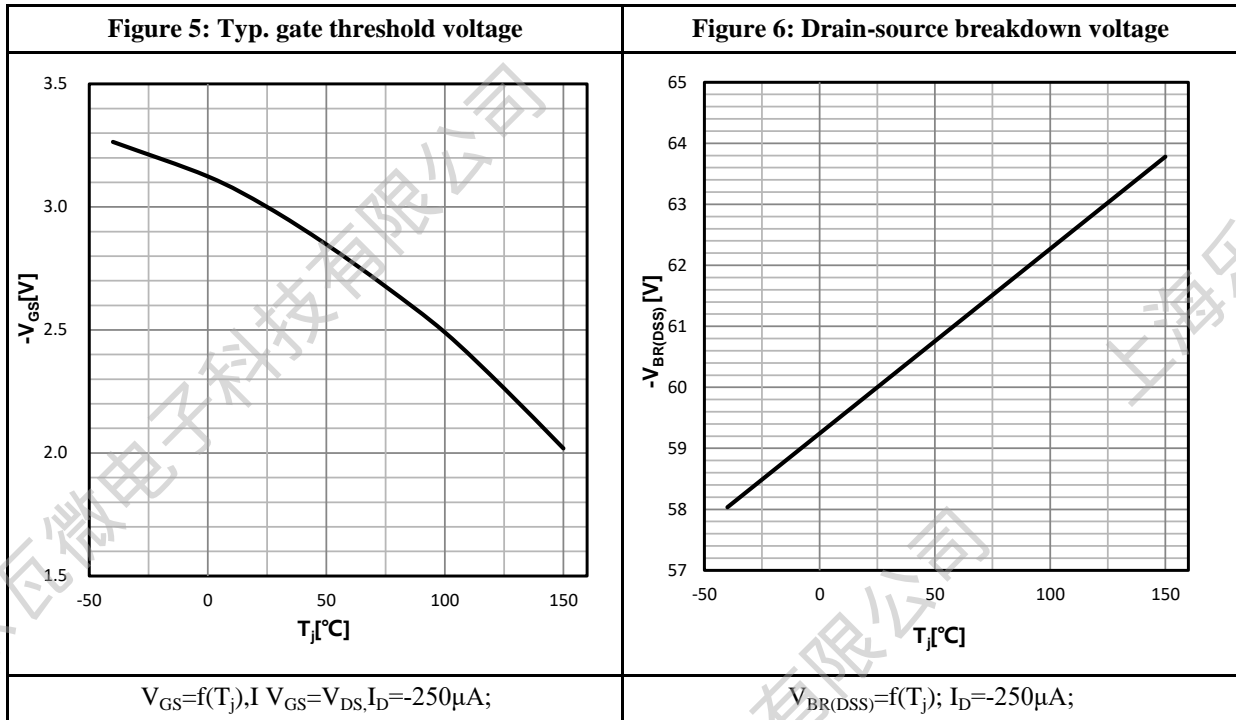

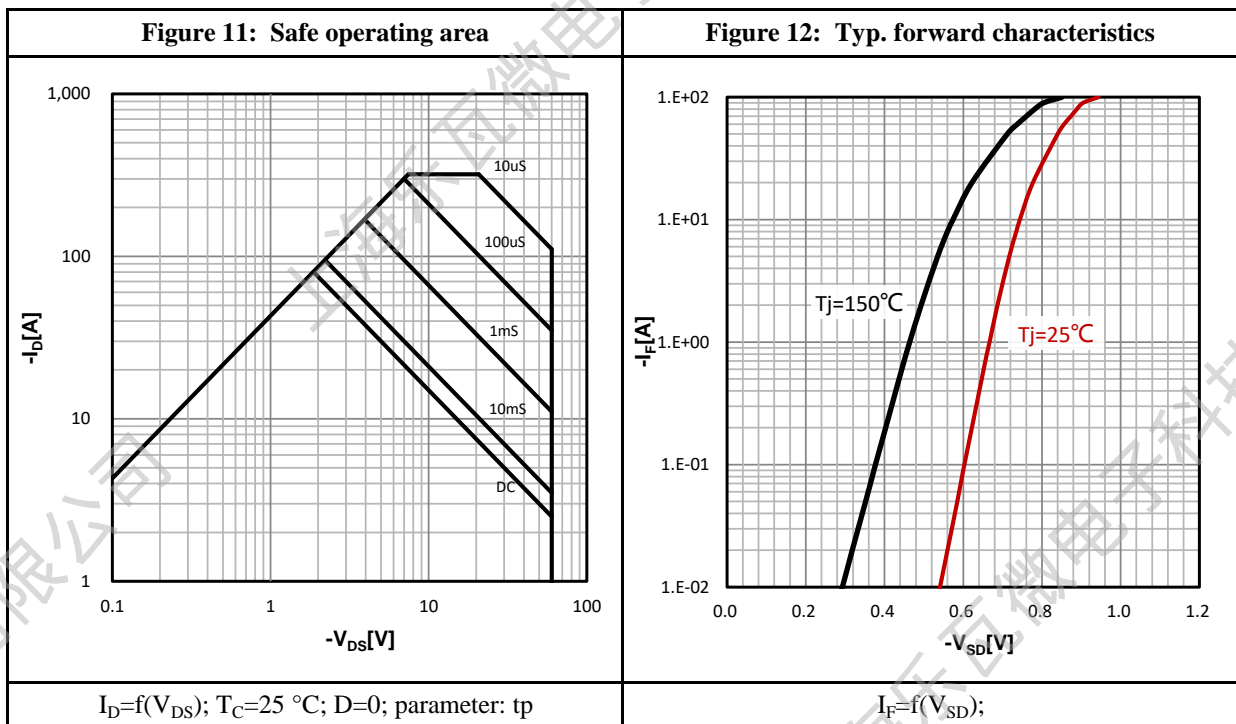
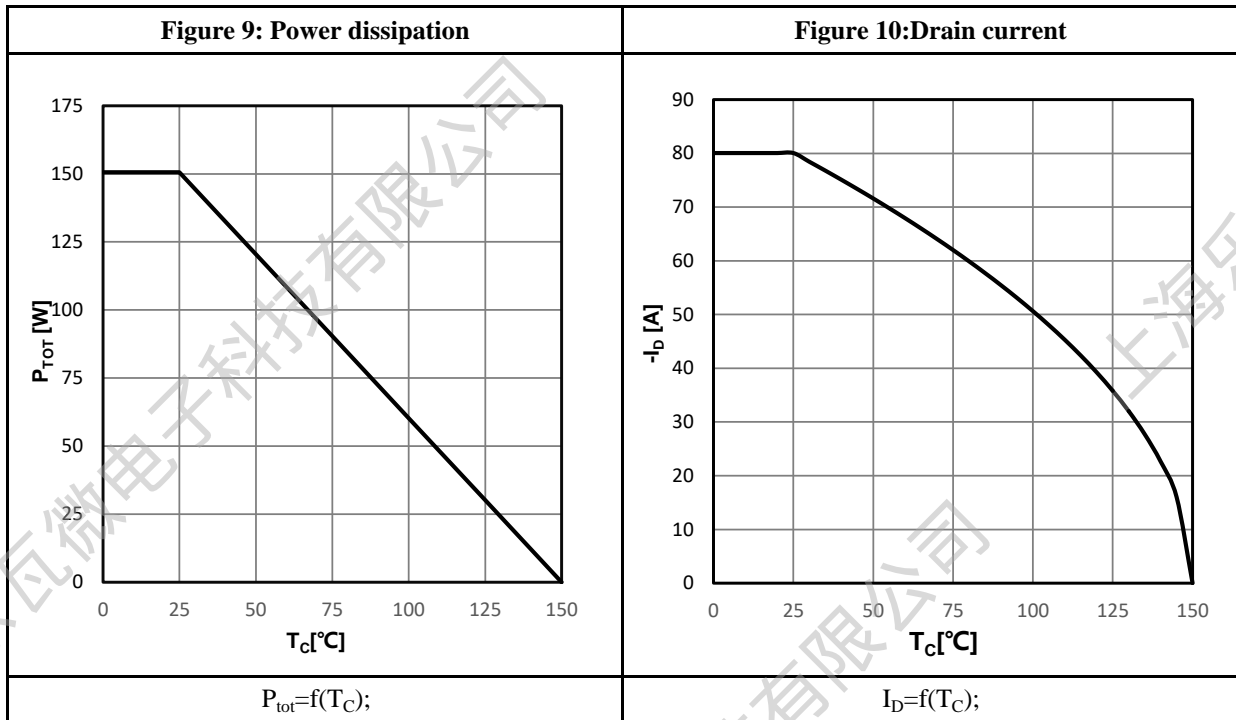

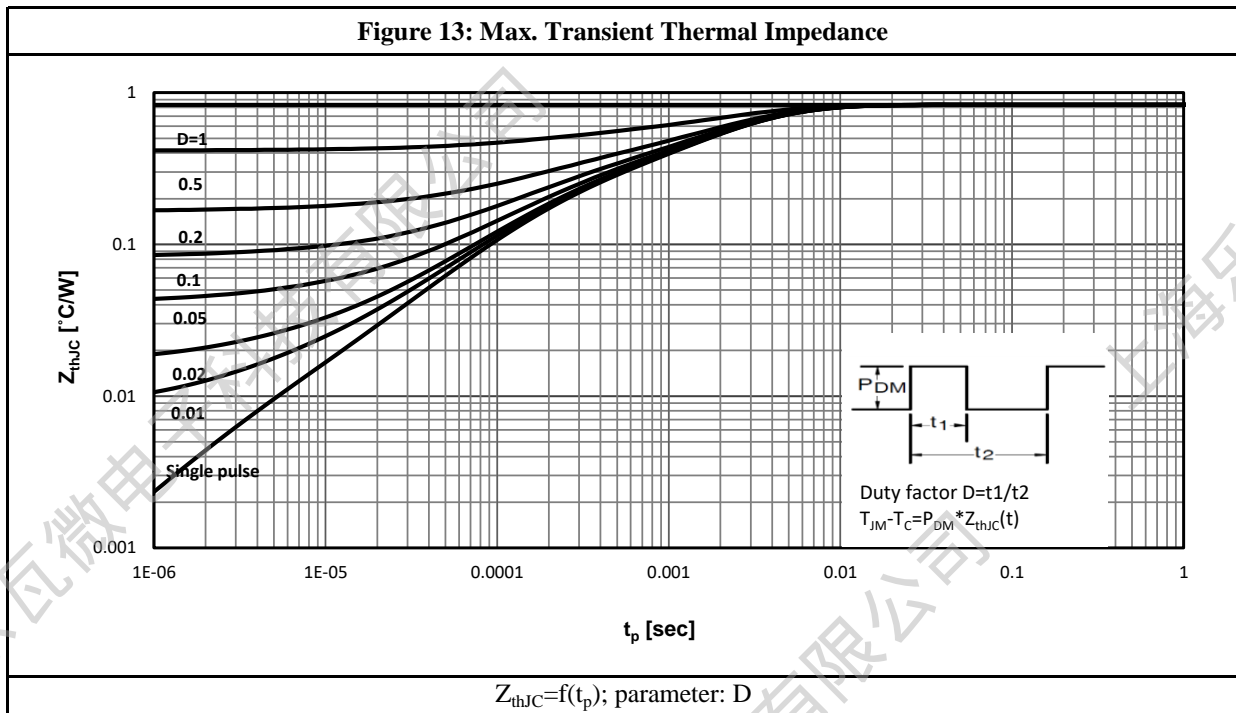

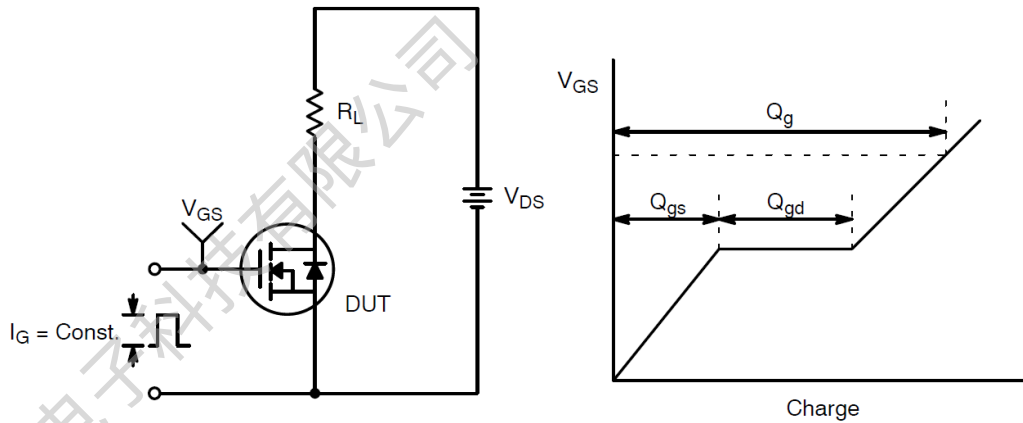
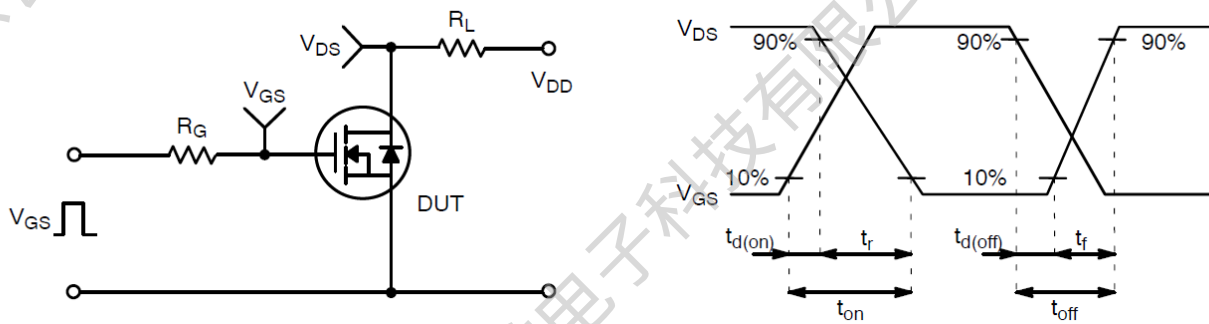
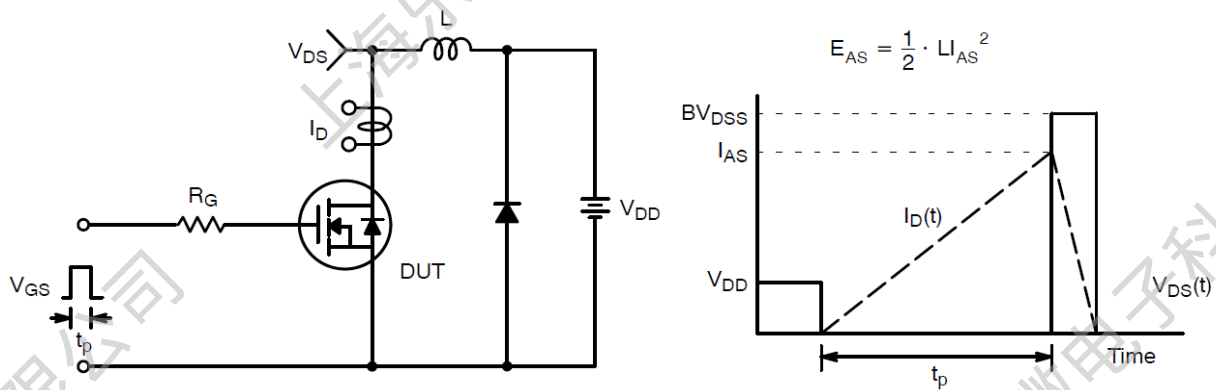
**Test Circuit & Waveform:**

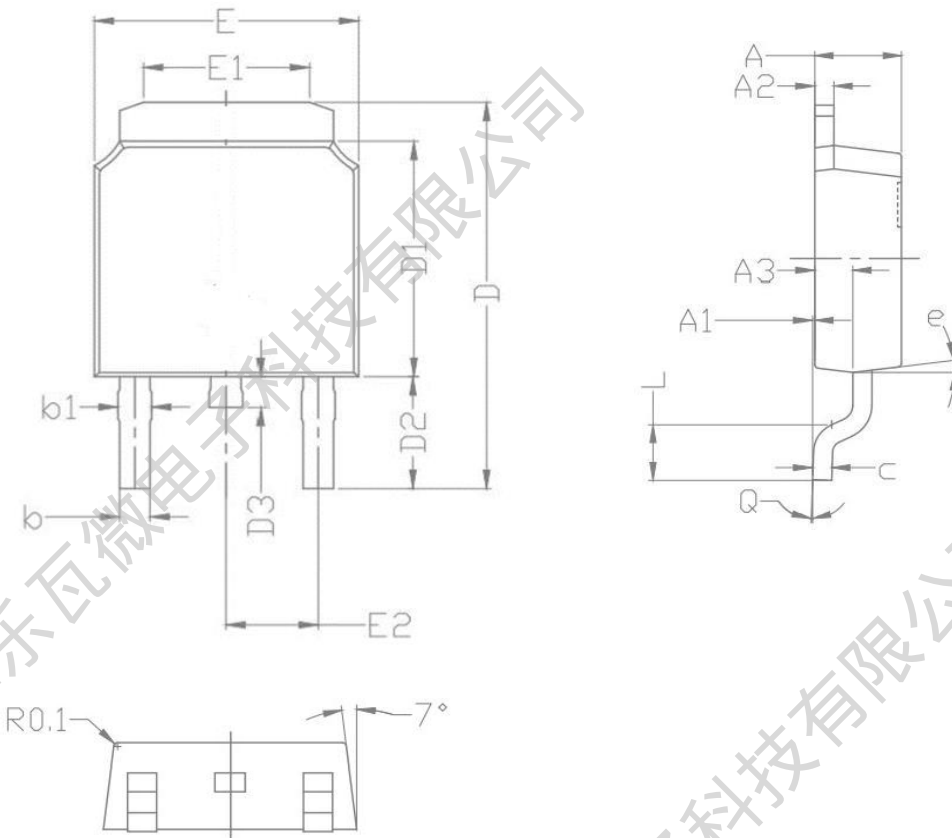
**Figure 14: Gate Charge Test Circuit & Waveform**

**Figure 15: Resistive Switching Test Circuit & Waveforms**

**Figure 16: Unclamped Inductive Switching Test Circuit & Waveforms**

**Package Outline:**

COMMON			
PKG	TO-252-2L		
Symbol	Min	Nom	Max
A	2.200	2.300	2.400
A1	0.000	0.075	0.150
A2	0.500	0.508	0.550
A3	0.960	1.010	1.060
b	0.740	0.760	0.800
b1	0.880	0.900	0.950
C	0.500	0.508	0.550
D	9.800	10.025	10.350
D1	6.050	6.100	6.180
D2	2.850	2.900	2.950
D3	0.600	0.800	1.000
E	6.550	6.600	6.700
E1	4.050	4.130	4.200
E2	2.25	2.286	2.3
L	1.400	1.500	1.600
e	7°		
Q	0°	2°	5°



**Revision History:**

<b>Revison</b>	<b>Date</b>	<b>Descriptions</b>
Rev 1.0	July.2022	Initial Version

**Disclaimer:**

The information in this document is believed to be accurate and reliable. However, no responsibility is assumed by LW-Micro for its use. All operating parameters must be designed, validated and tested to ensure they meet the requirements of your application. LW-Micro reserves the right to make any specification and/or circuitry changes without prior notification. Before starting a brand-new project, please contact LW-Micro Sales to get the most recent relevant information.

Mailing Address: Room 301, Building 2, No.1690 CaiLun Road, China (Shanghai) Pilot Free Trade Zone  
Shanghai Lewa Micro-electronics Technology Co., Ltd