

General Description:

The LWS6010AD5 uses advanced SGT technology and design to provide excellent $R_{DS(ON)}$ with low gate charge. It can be used in a wide variety of applications. The package form is PDFN5*6-8L, which accords with the ROHS standard and Halogen Free standard.

Features:

- Fast Switching
- Low Gate Charge and $R_{DS(ON)}$
- Low Reverse transfer capacitances

Applications:

- Battery switching application
- Hard switched and high frequency circuits
- Power Management

100% DVDS Tested

100% Avalanche Tested

Package Marking and Ordering Information:

Marking	Part Number	Package	Packing	Qty.
S6010/LW D5/D.C.	LWS6010AD5	PDFN5*6-8L	Reel	5000 Pcs

Absolute Maximum Ratings:

Symbol	Parameter	Value	Units
V_{DSS}	Drain-to-Source Voltage	-60	V
I_D	Continuous Drain Current	$T_C=25^\circ\text{C}$	-60
	Continuous Drain Current	$T_C=100^\circ\text{C}$	-38
I_{DM}^{a1}	Pulsed Drain Current	-240	A
V_{GS}	Gate-to-Source Voltage	± 20	V
P_D	Power Dissipation	104	W
E_{AS}^{a2}	Single pulse avalanche energy	612	mJ
T_J, T_{STG}	Operating Junction and Storage Temperature Range	150, -55 to 150	$^\circ\text{C}$
T_L	Maximum Temperature for Soldering	260	$^\circ\text{C}$

Thermal Characteristics:

Symbol	Parameter	Value	Units
$R_{\theta JC}$	Thermal Resistance, Junction-to-Case	1.20	$^\circ\text{C}/\text{W}$
$R_{\theta JA}$	Thermal Resistance, Junction-to-Ambient	70	$^\circ\text{C}/\text{W}$

V_{DSS}	-60	V
I_D	-60	A
P_D	104	W
$R_{DS(ON) \text{ TYPE}}$	9.0	$\text{m}\Omega$

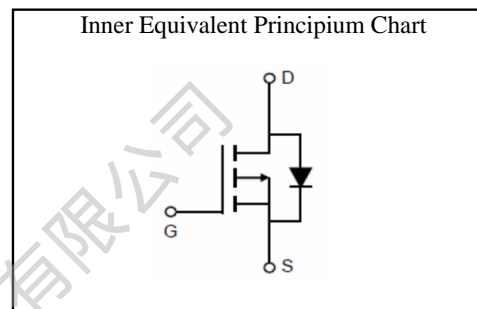
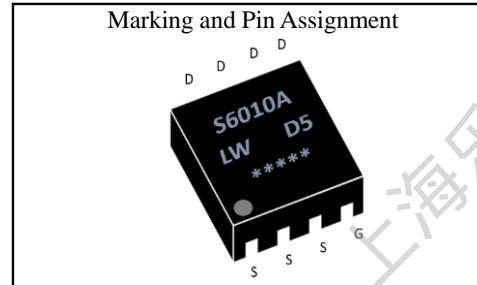

Electrical Characteristic ($T_A = 25\text{ }^\circ\text{C}$, unless otherwise specified):

Static Characteristics						
Symbol	Parameter	Test Conditions	Value			Units
			Min.	Typ.	Max.	
V_{DSS}	Drain to Source Breakdown Voltage	$V_{GS}=0V, I_D=-250\mu A$	-60	--	--	V
I_{DSS}	Drain to Source Leakage Current	$V_{DS}=-60V, V_{GS}=0V$	--	--	1.0	μA
$I_{GSS(F)}$	Gate to Source Forward Leakage	$V_{GS}=-20V, V_{DS}=0V$	--	--	100	nA
$I_{GSS(R)}$	Gate to Source Reverse Leakage	$V_{GS}=+20V, V_{DS}=0V$	--	--	-100	nA
$V_{GS(TH)}$	Gate Threshold Voltage	$V_{DS}=V_{GS}, I_D=-250\mu A$	-1.3	-1.8	-2.3	V
$R_{DS(ON)1}$	Drain-to-Source On-Resistance	$V_{GS}=-10V, I_D=-20A$	--	9.0	11.0	m Ω
$R_{DS(ON)2}$	Drain-to-Source On-Resistance	$V_{GS}=-4.5V, I_D=-15A$	--	12.0	15.0	m Ω
g_{FS}	Forward Transconductance	$V_{DS}=-10V, I_D=-20A$	--	50	--	S

Dynamic Characteristics						
Symbol	Parameter	Test Conditions	Value			Units
			Min.	Typ.	Max.	
C_{iss}	Input Capacitance	$V_{GS} = 0V$	--	3959	--	pF
C_{oss}	Output Capacitance	$V_{DS} = -30V$	--	611	--	
C_{rss}	Reverse Transfer Capacitance	$f = 1.0MHz$	--	34	--	
R_G	Gate resistance	$V_{GS}=0V, V_{DS}$ Open	--	2.0	--	Ω

Resistive Switching Characteristics						
Symbol	Parameter	Test Conditions	Value			Units
			Min.	Typ.	Max.	
$t_{d(ON)}$	Turn-on Delay Time	$I_D = -20A$	--	4.5	--	ns
t_r	Rise Time	$V_{DS} = -30V$	--	2.5	--	
$t_{d(OFF)}$	Turn-Off Delay Time	$V_{GS} = -10V$	--	14.5	--	
t_f	Fall Time	$R_G = 3\Omega$	--	3.5	--	
Q_g	Total Gate Charge	$V_{GS} = -10V$	--	47	--	nC
Q_{gs}	Gate Source Charge	$V_{DS} = -30V$	--	11	--	
Q_{gd}	Gate Drain Charge	$I_D = -20A$	--	9	--	

Source-Drain Diode Characteristics						
Symbol	Parameter	Test Conditions	Value			Units
			Min.	Typ.	Max.	
I_S	Diode Forward Current	$T_C = 25\text{ }^\circ\text{C}$	--	--	-60	A
I_{SM}	Diode Pulse Current		--	--	-240	A
V_{SD}	Diode Forward Voltage	$I_S = -20A, V_{GS} = 0V$	--	--	-1.2	V
t_{rr}	Reverse Recovery time	$I_S = -20A, V_{DD} = -30V,$	--	60	--	ns
Q_{rr}	Reverse Recovery Charge	$dI/dt = 100A/\mu s$	--	105	--	nC

a1: Repetitive rating; pulse width limited by maximum junction temperature

a2: $V_{DD} = -30V, L = 1.0mH, R_G = 25\Omega, \text{Starting } T_j = 25\text{ }^\circ\text{C}$

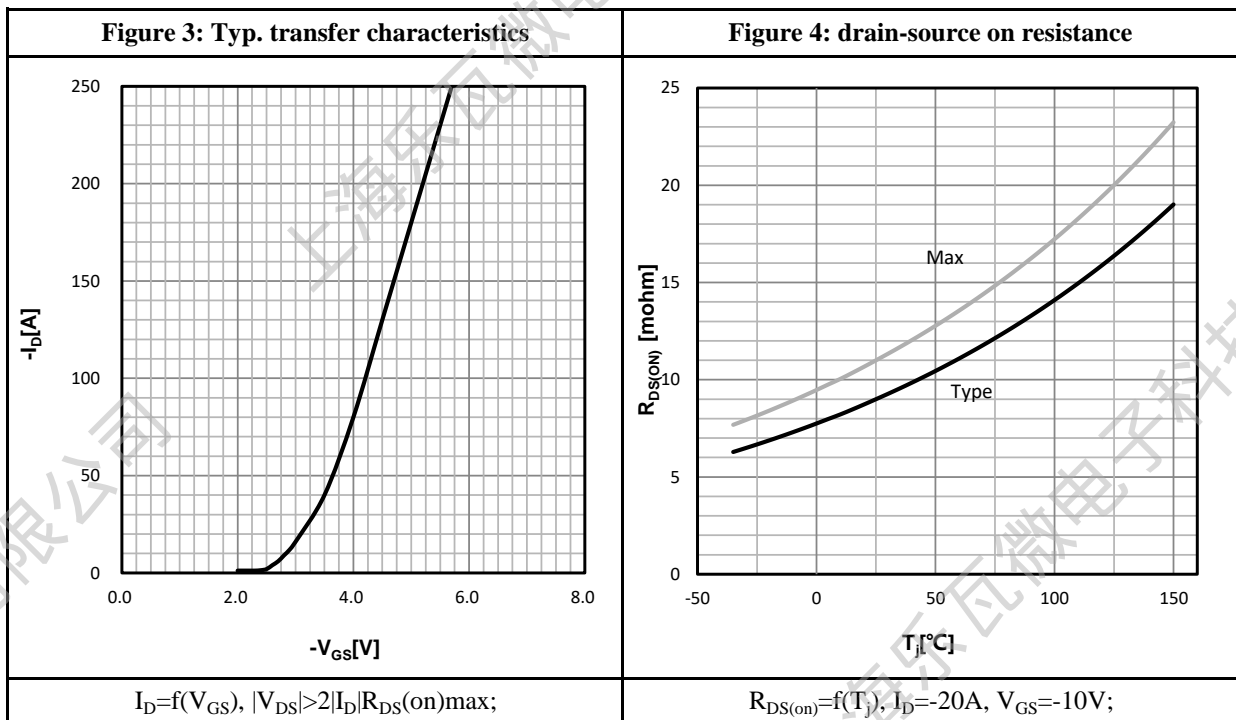
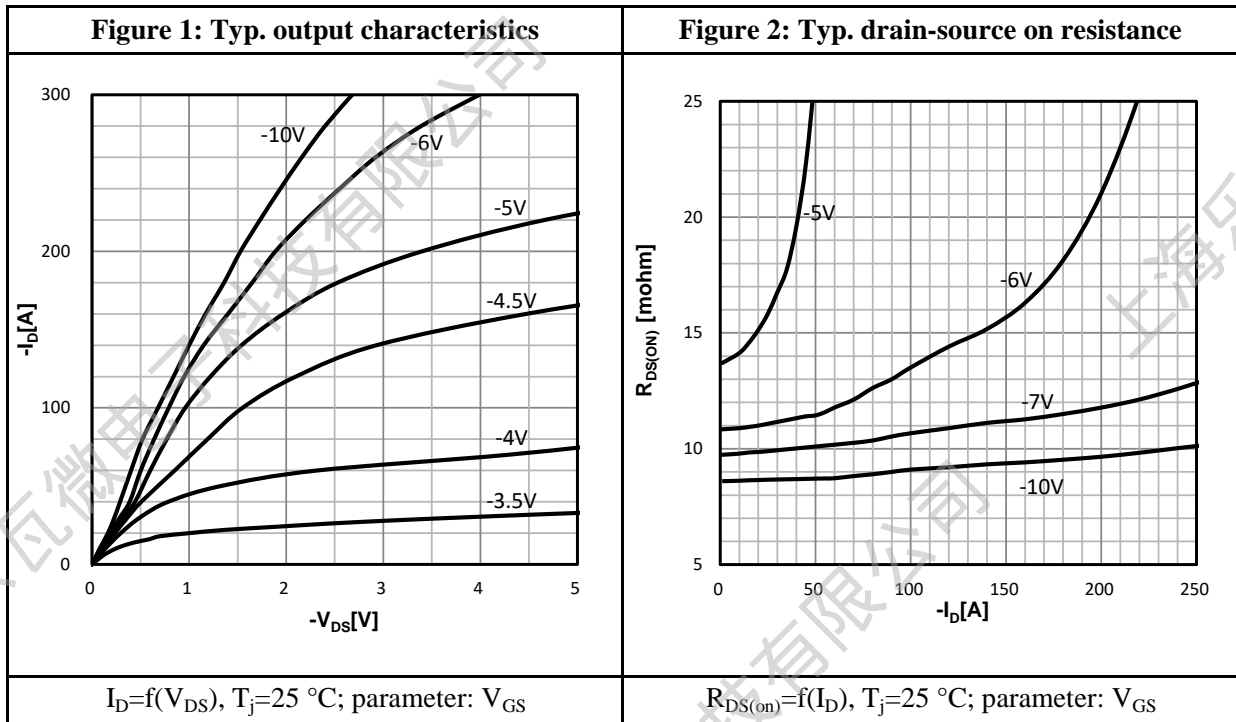
Characteristics Curve:

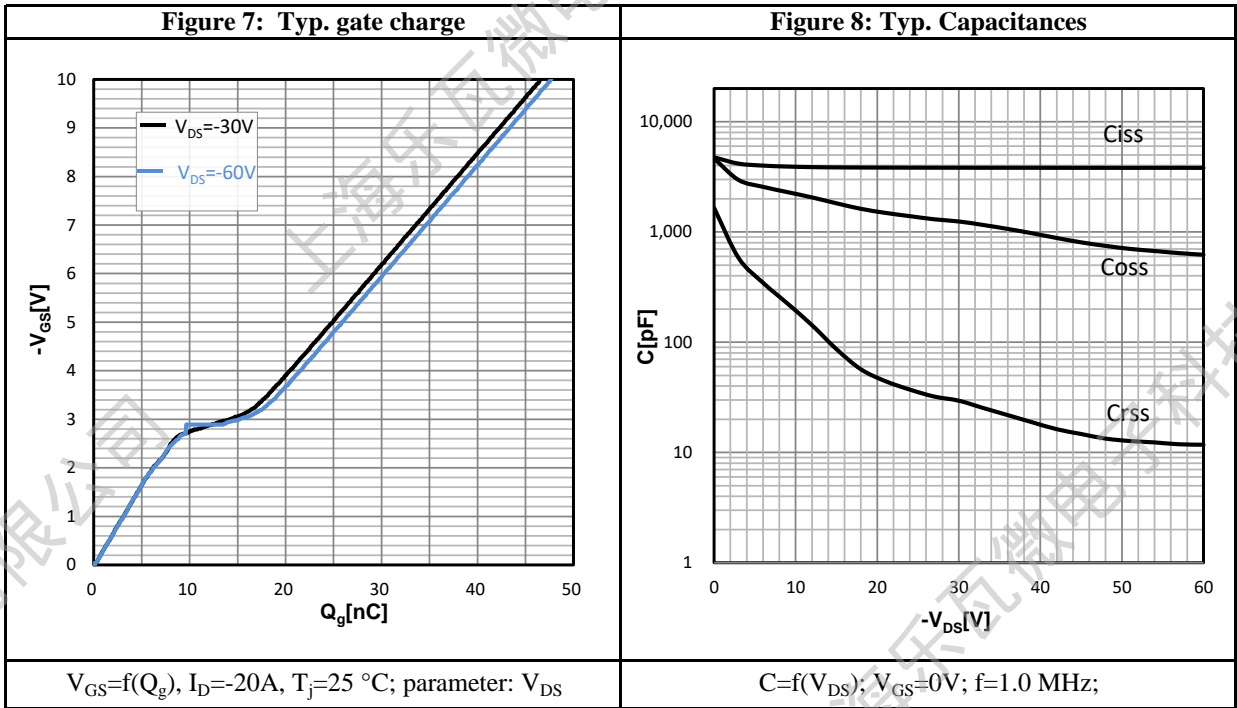
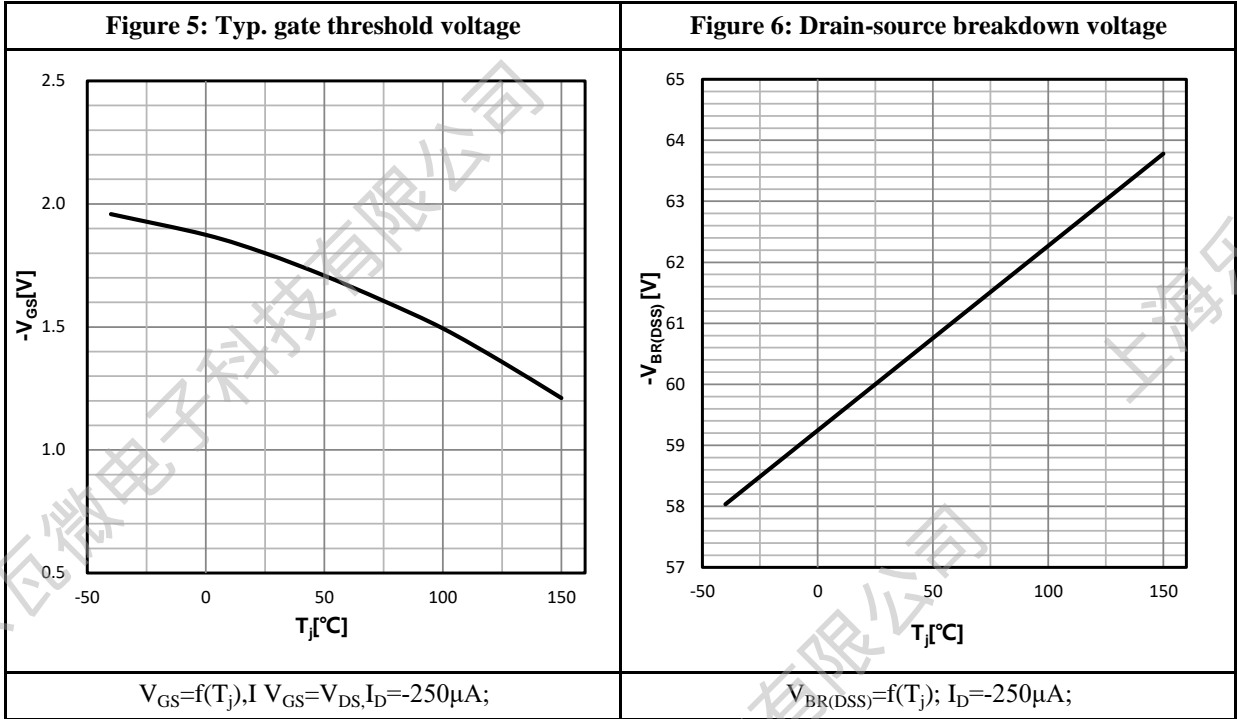

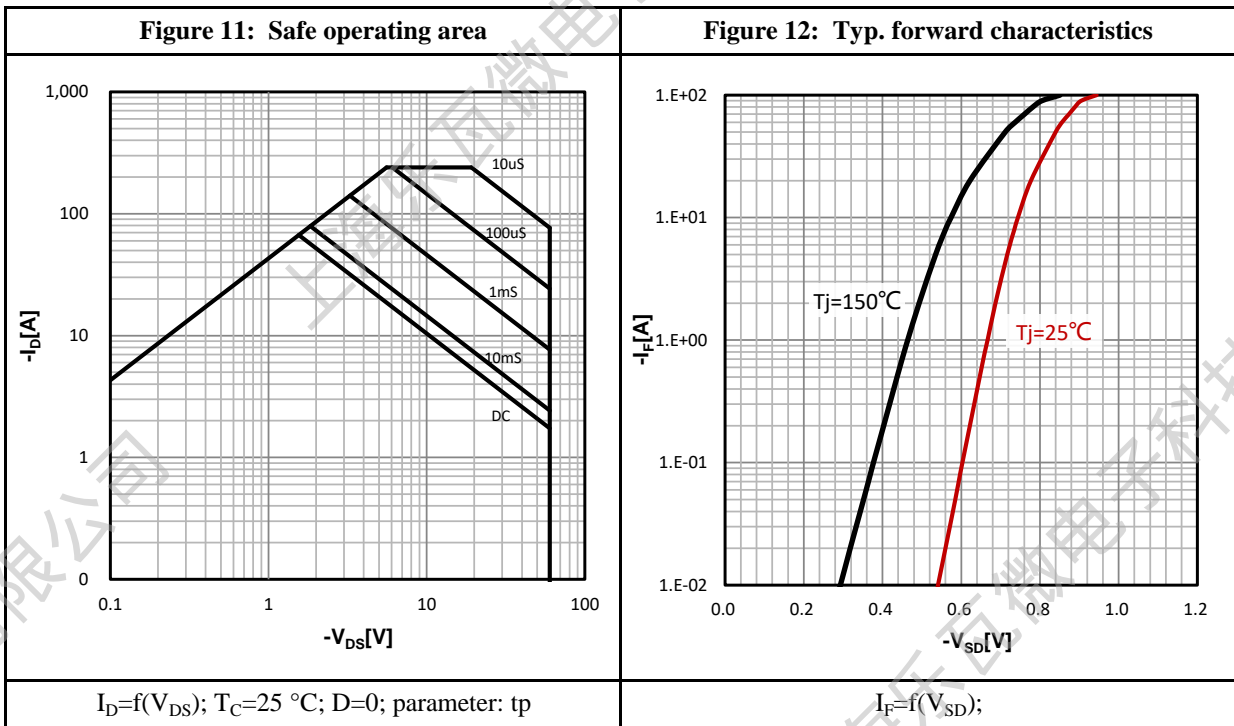
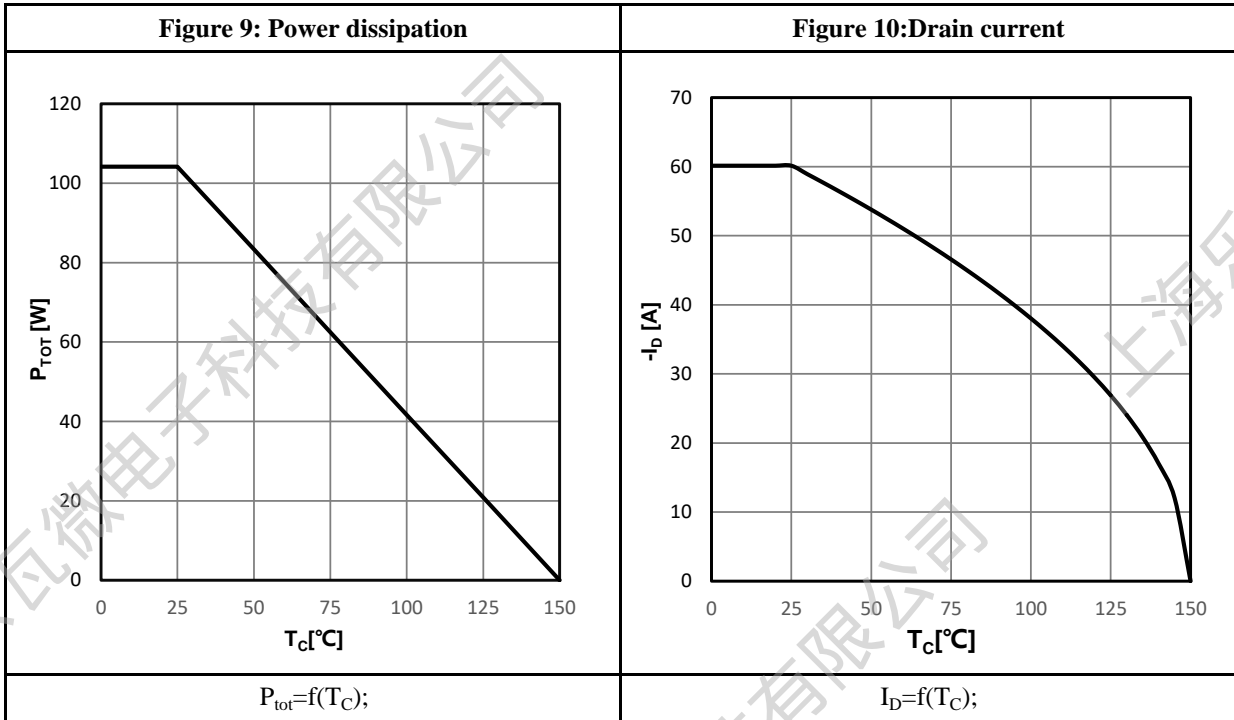

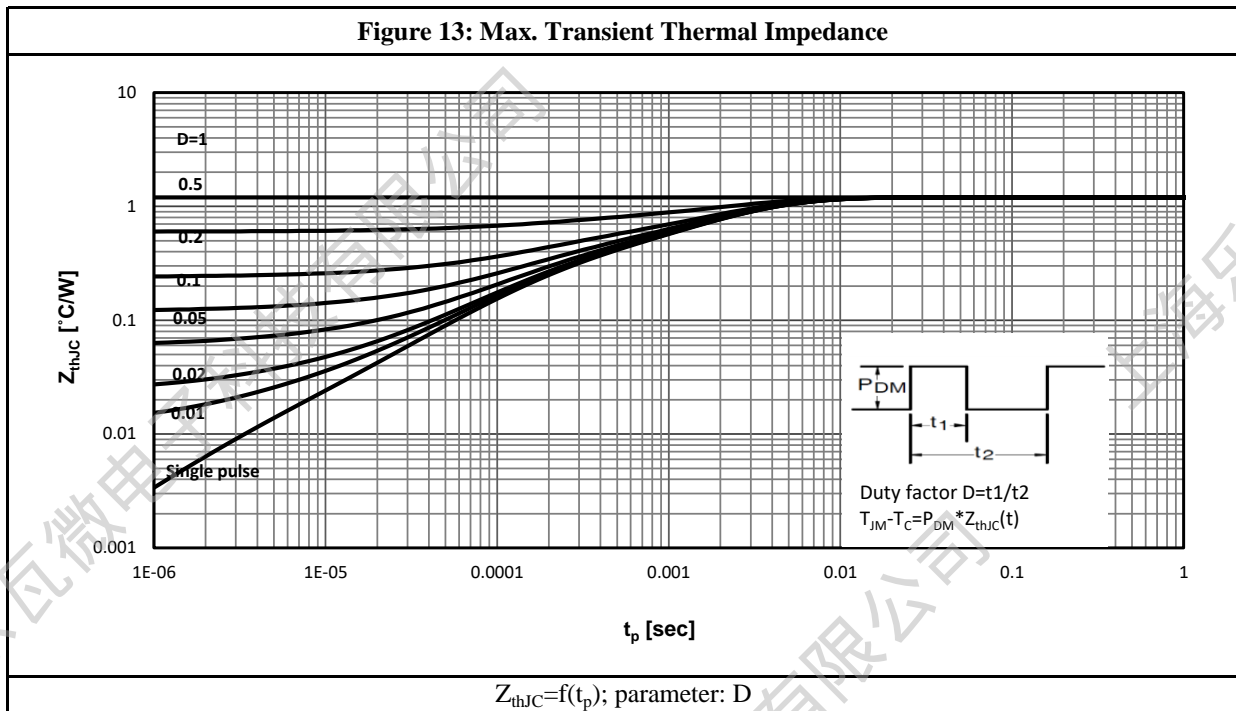

Test Circuit & Waveform:

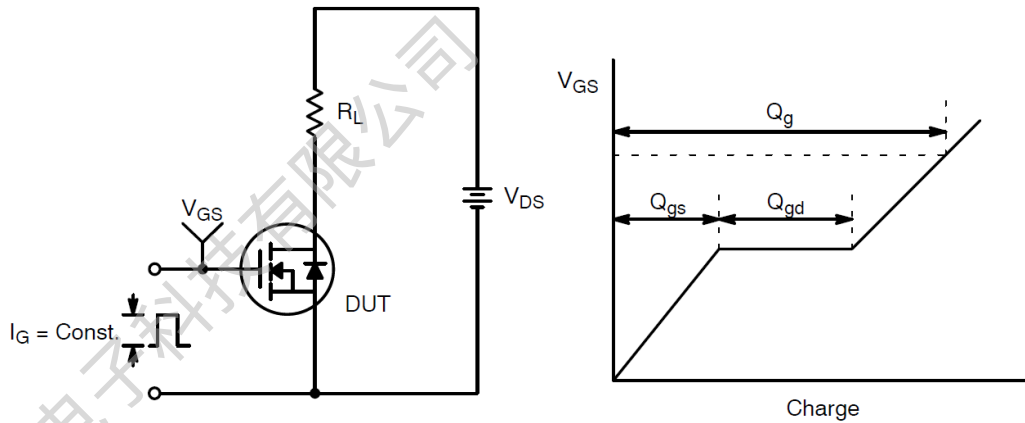

Figure 14: Gate Charge Test Circuit & Waveform



Figure 15: Resistive Switching Test Circuit & Waveforms

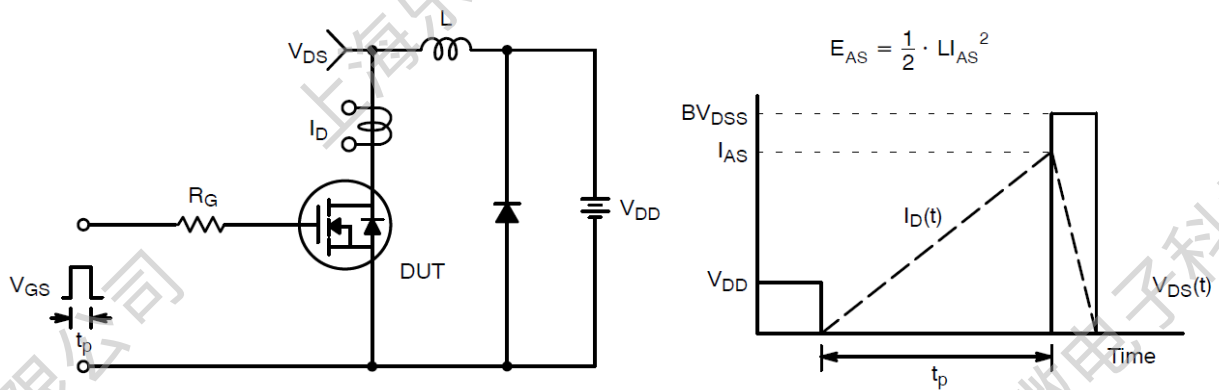
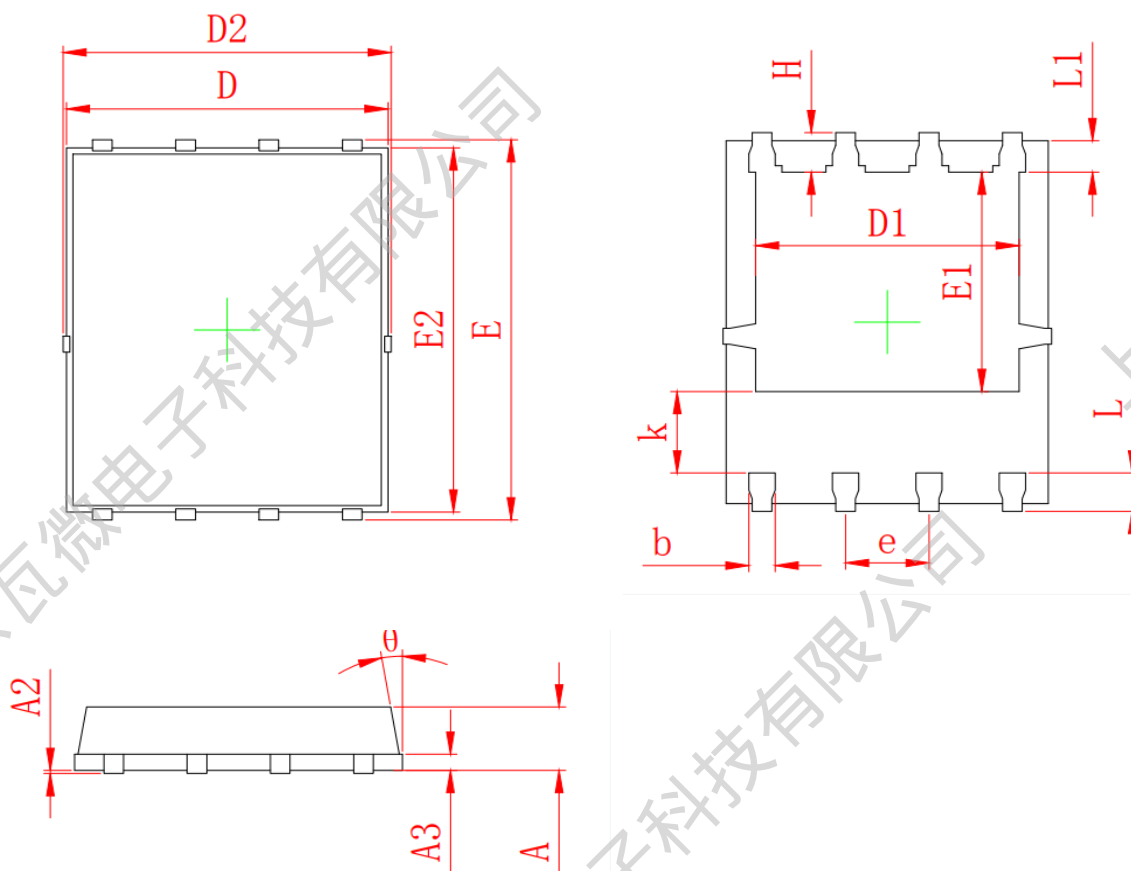

Figure 16: Unclamped Inductive Switching Test Circuit & Waveforms

Package Outline:

Symbol	MILLIMETER	
	Min	Max
A	0.900	1.100
A1	0.254 REF	
A2	0~0.050	
D	4.824	4.976
D1	3.910	4.110
D2	4.944	5.076
E	5.924	6.076
E1	3.375	3.575
E2	5.674	5.826
b	0.350	0.450
e	1.270 TYP	
L	0.534	0.686
L1	0.424	0.576
k	1.190	1.390
H	0.549	0.701

Revision History:

Revison	Date	Descriptions
Rev 1.0	July.2022	Initial Version

Disclaimer:

The information in this document is believed to be accurate and reliable. However, no responsibility is assumed by LW-Micro for its use. All operating parameters must be designed, validated and tested to ensure they meet the requirements of your application. LW-Micro reserves the right to make any specification and/or circuitry changes without prior notification. Before starting a brand-new project, please contact LW-Micro Sales to get the most recent relevant information.

Mailing Address: Room 301, Building 2, No.1690 CaiLun Road, China (Shanghai) Pilot Free Trade Zone
Shanghai Lewa Micro-electronics Technology Co., Ltd