

General Description:

The LWS6080A4 uses advanced SGT technology and design to provide excellent $R_{DS(ON)}$ with low gate charge. It can be used in a wide variety of applications. The package form is TO-252, which accords with the ROHS standard and Halogen Free standard.

Features:

- Fast Switching
- Low Gate Charge and $R_{DS(ON)}$
- Low Reverse transfer capacitances

Applications:

- Battery switching application
- Hard switched and high frequency circuits
- Power Management

100% DVDS Tested

100% Avalanche Tested

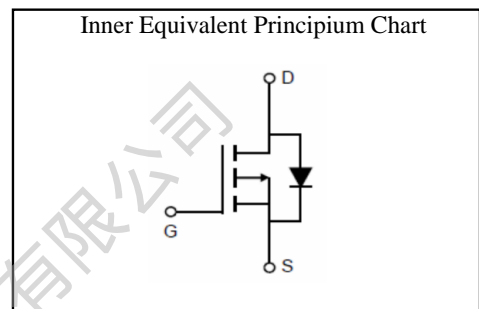
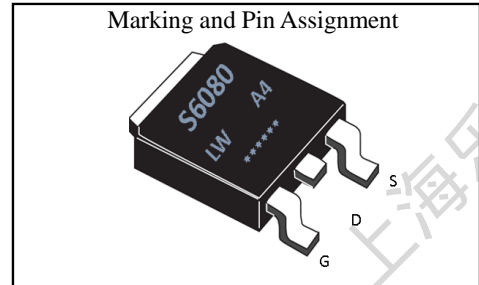

V_{DSS}	-60	V
I_D	-16	A
P_D	32	W
$R_{DS(ON)}$ TYPE	60	m Ω

Package Marking and Ordering Information:

Marking	Part Number	Package	Packing	Qty.
S6080/LW A4/D.C.	LWS6080A4	TO-252	Reel	2500 Pcs

Absolute Maximum Ratings:

Symbol	Parameter	Value	Units
V_{DSS}	Drain-to-Source Voltage	-60	V
I_D	Continuous Drain Current	$T_C=25^\circ\text{C}$	-16
	Continuous Drain Current	$T_C=100^\circ\text{C}$	-10
I_{DM}^{a1}	Pulsed Drain Current	-64	A
V_{GS}	Gate-to-Source Voltage	± 20	V
P_D	Power Dissipation	32	W
E_{AS}^{a2}	Single pulse avalanche energy	48	mJ
T_J, T_{STG}	Operating Junction and Storage Temperature Range	150, -55 to 150	$^\circ\text{C}$
T_L	Maximum Temperature for Soldering	260	$^\circ\text{C}$

Thermal Characteristics:

Symbol	Parameter	Value	Units
$R_{\theta JC}$	Thermal Resistance, Junction-to-Case	3.9	$^\circ\text{C}/\text{W}$

Electrical Characteristic ($T_A = 25\text{ }^\circ\text{C}$, unless otherwise specified):

Static Characteristics						
Symbol	Parameter	Test Conditions	Value			Units
			Min.	Typ.	Max.	
V_{DSS}	Drain to Source Breakdown Voltage	$V_{GS}=0V, I_D=-250\mu A$	-60	--	--	V
I_{DSS}	Drain to Source Leakage Current	$V_{DS}=-60V, V_{GS}=0V$	--	--	1.0	μA
$I_{GSS(F)}$	Gate to Source Forward Leakage	$V_{GS}=-20V, V_{DS}=0V$	--	--	100	nA
$I_{GSS(R)}$	Gate to Source Reverse Leakage	$V_{GS}=+20V, V_{DS}=0V$	--	--	-100	nA
$V_{GS(TH)}$	Gate Threshold Voltage	$V_{DS}=V_{GS}, I_D=-250\mu A$	-1.3	-1.65	-2.1	V
$R_{DS(ON)1}$	Drain-to-Source On-Resistance	$V_{GS}=-10V, I_D=-5.0A$	--	60	75	$m\Omega$
$R_{DS(ON)2}$	Drain-to-Source On-Resistance	$V_{GS}=-4.5V, I_D=-4.0A$	--	75	100	$m\Omega$

Dynamic Characteristics						
Symbol	Parameter	Test Conditions	Value			Units
			Min.	Typ.	Max.	
C_{iss}	Input Capacitance	$V_{GS} = 0V$	--	504	--	pF
C_{oss}	Output Capacitance	$V_{DS} = -30V$	--	82	--	
C_{rss}	Reverse Transfer Capacitance	$f = 1.0MHz$	--	3.9	--	
R_G	Gate resistance	$V_{GS}=0V, V_{DS}$ Open	--	3.0	--	Ω

Resistive Switching Characteristics						
Symbol	Parameter	Test Conditions	Value			Units
			Min.	Typ.	Max.	
$t_{d(ON)}$	Turn-on Delay Time	$I_D = -5A$	--	10	--	ns
t_r	Rise Time	$V_{DS} = -30V$	--	6.0	--	
$t_{d(OFF)}$	Turn-Off Delay Time	$V_{GS} = -10V$	--	40	--	
t_f	Fall Time	$R_G = 3\Omega$	--	13	--	
Q_g	Total Gate Charge	$V_{GS} = -10V$	--	10.5	--	nC
Q_{gs}	Gate Source Charge	$V_{DS} = -30V$	--	2.8	--	
Q_{gd}	Gate Drain Charge	$I_D = -5A$	--	1.5	--	

Source-Drain Diode Characteristics						
Symbol	Parameter	Test Conditions	Value			Units
			Min.	Typ.	Max.	
I_S	Diode Forward Current	$T_C = 25\text{ }^\circ\text{C}$	--	--	-16	A
I_{SM}	Diode Pulse Current		--	--	-64	A
V_{SD}	Diode Forward Voltage	$I_S = -5A, V_{GS} = 0V$	--	--	-1.2	V
t_{rr}	Reverse Recovery time	$I_S = -5A, V_{DD} = -30V,$	--	50	--	ns
Q_{rr}	Reverse Recovery Charge	$dI/dt = 100A/us$	--	105	--	nC

a1: Repetitive rating; pulse width limited by maximum junction temperature

a2: $V_{DD} = -30V, L = 1.0mH, R_G = 25\Omega$, Starting $T_j = 25\text{ }^\circ\text{C}$

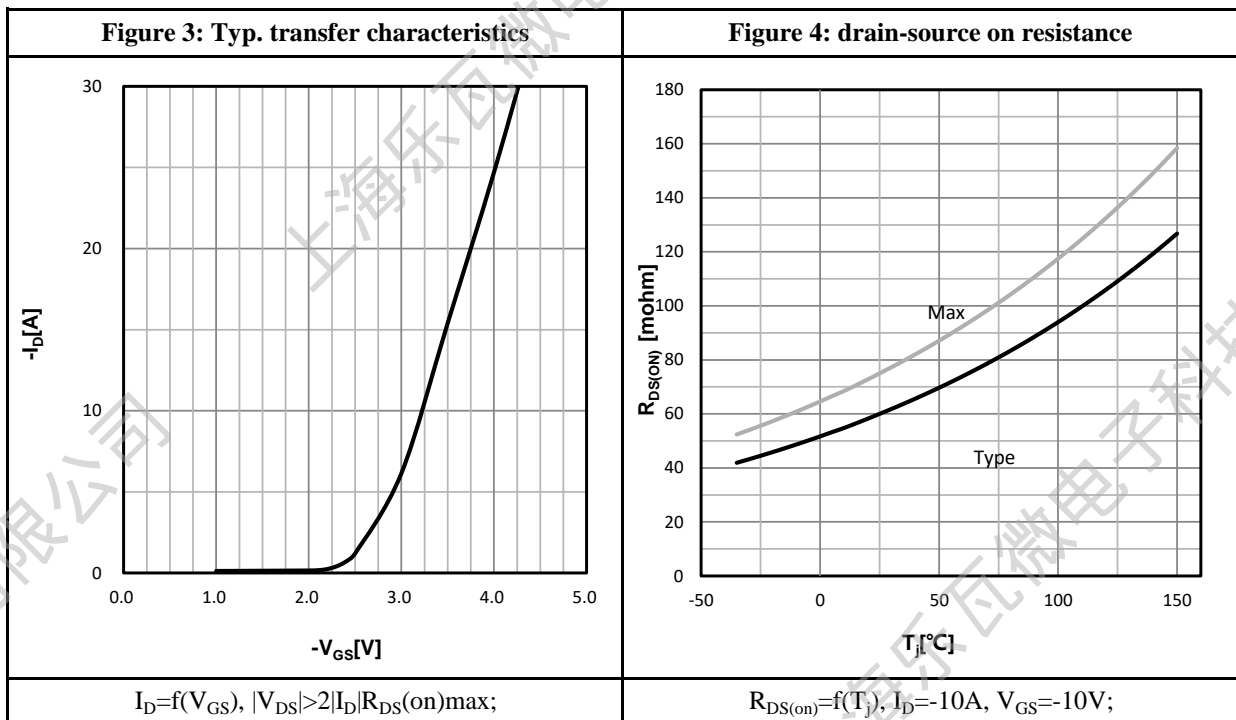
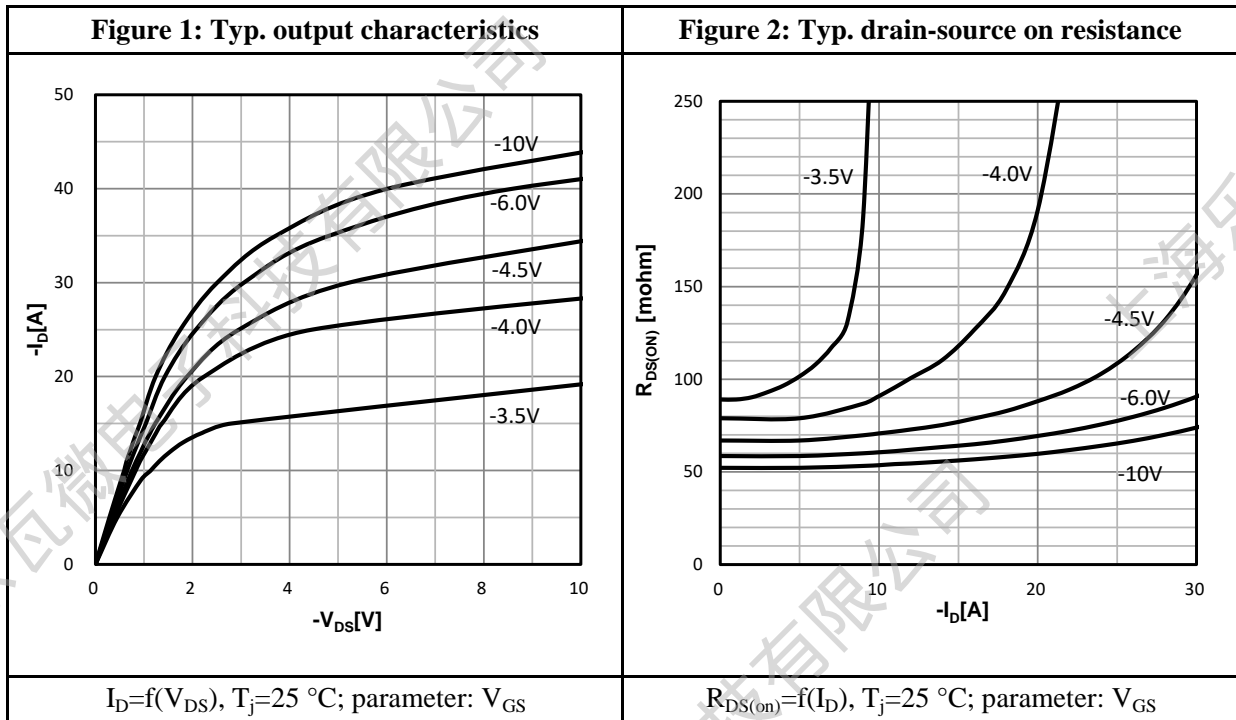
Characteristics Curve:

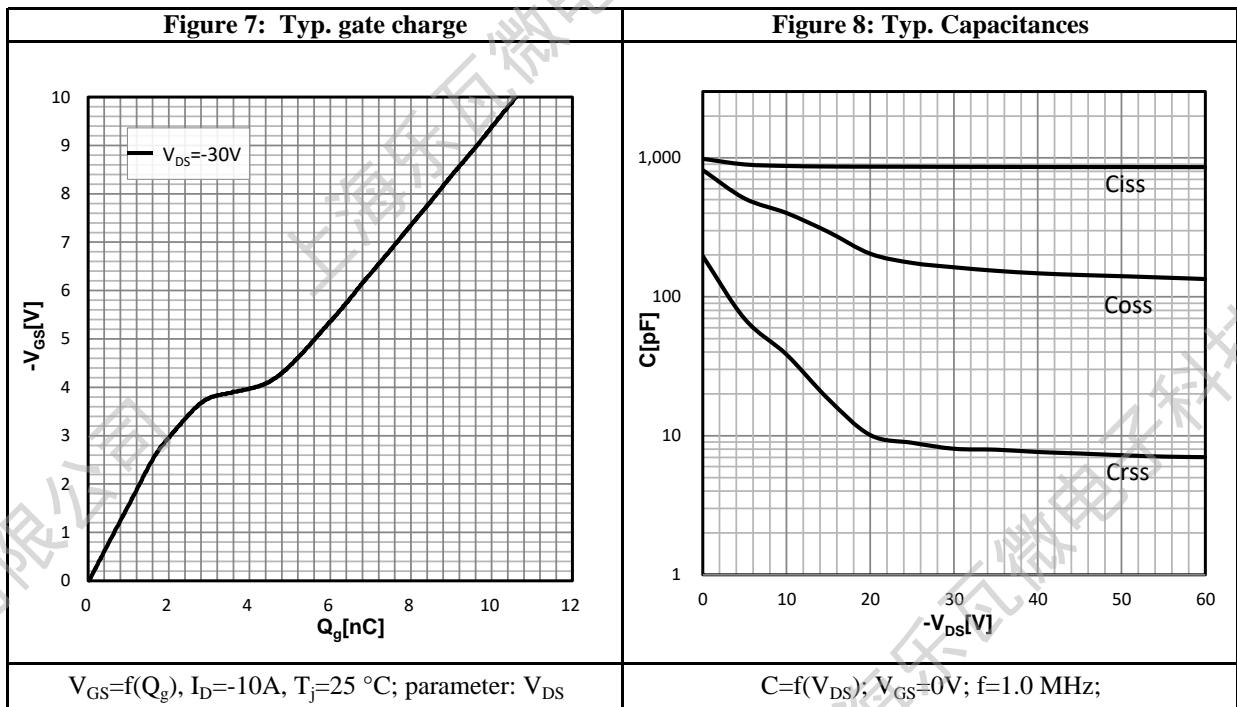
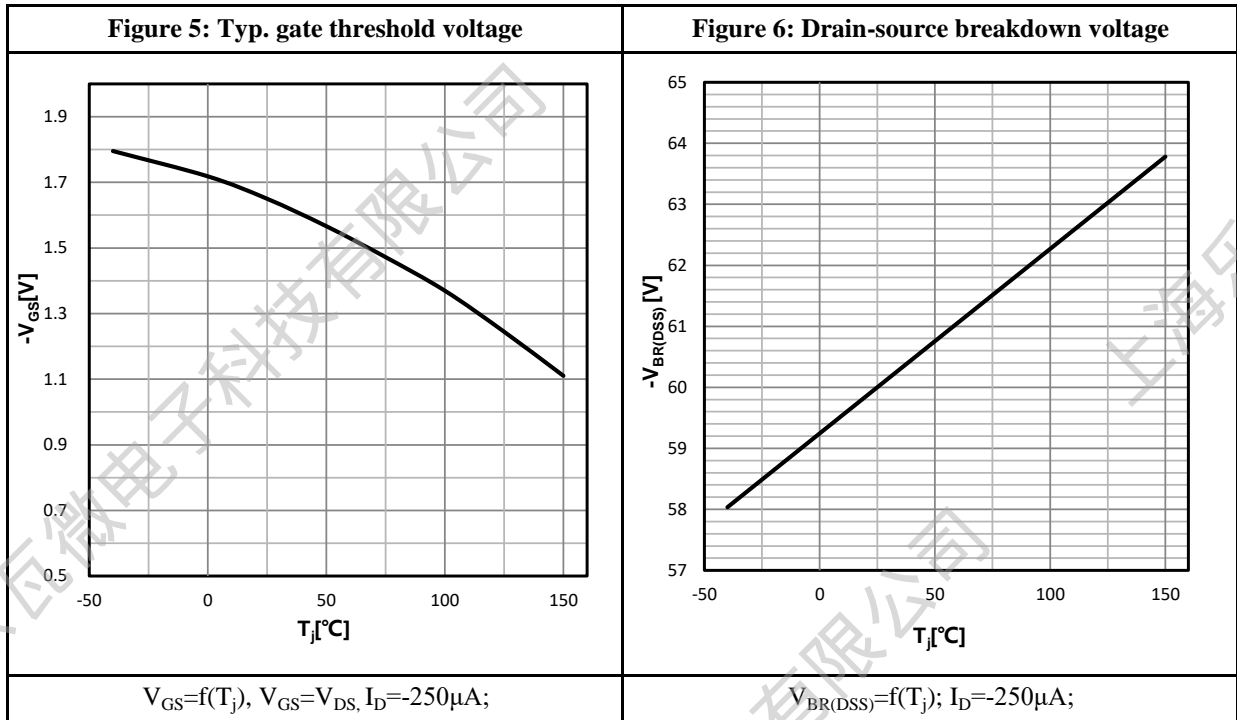

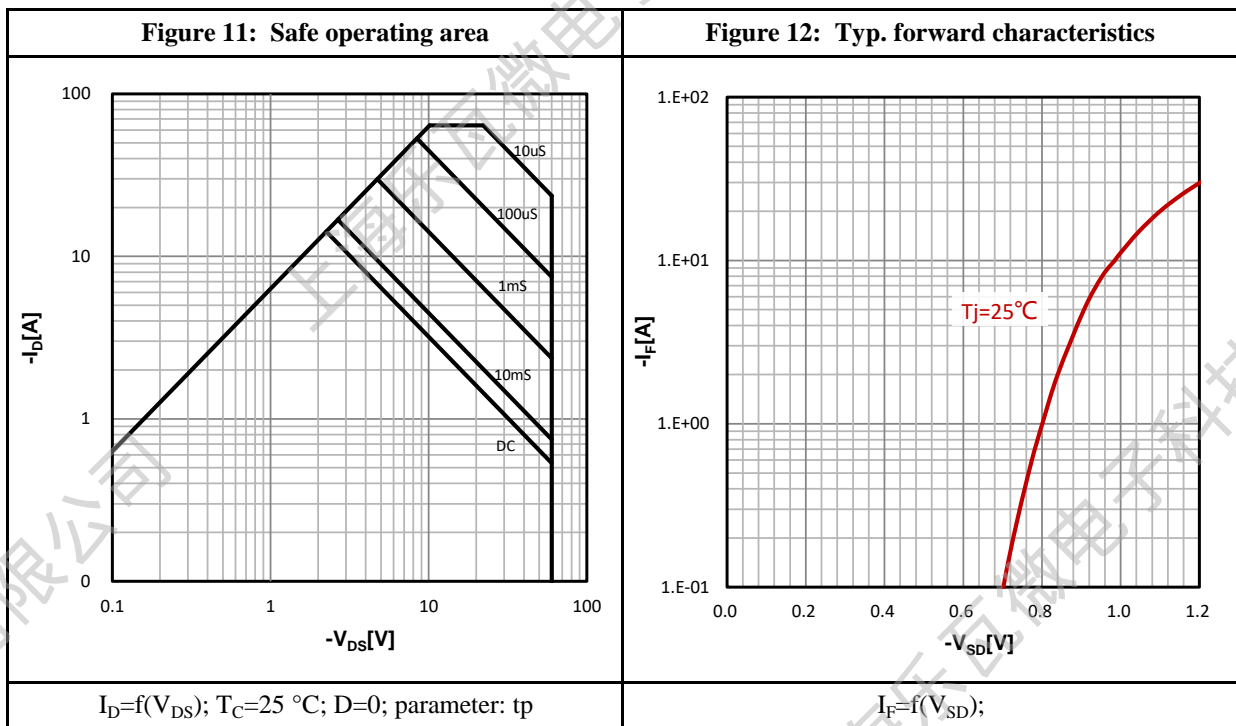
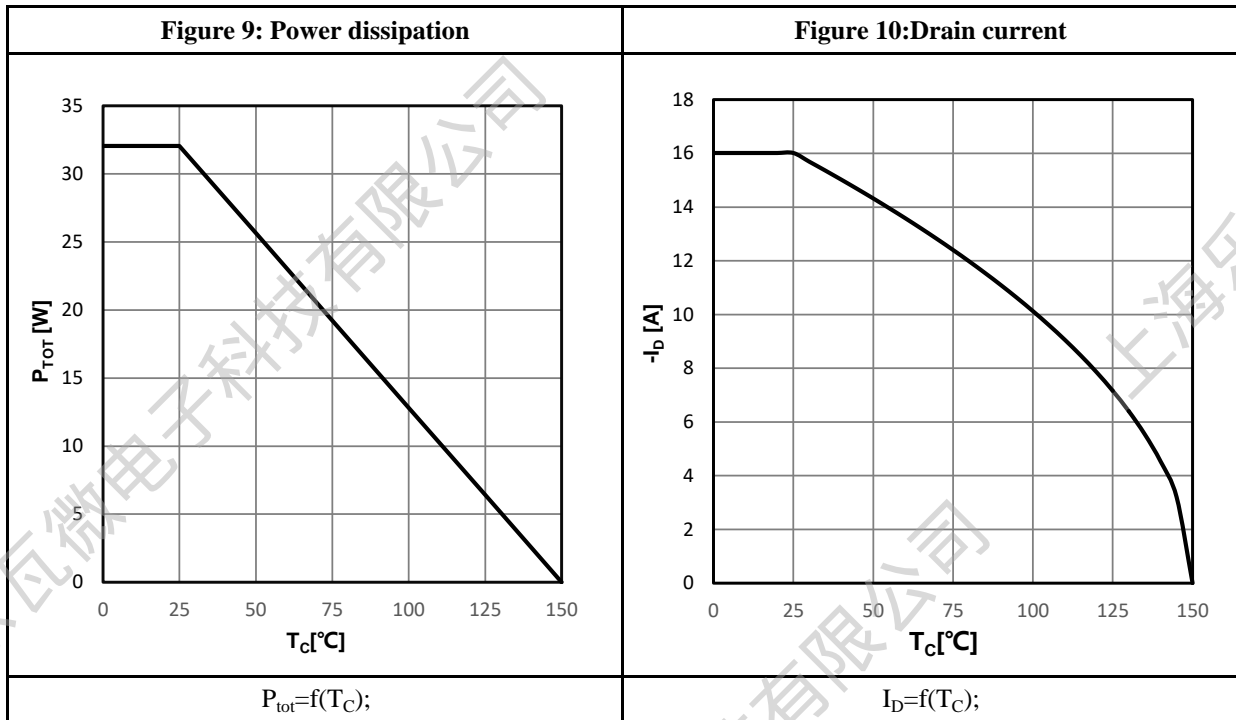

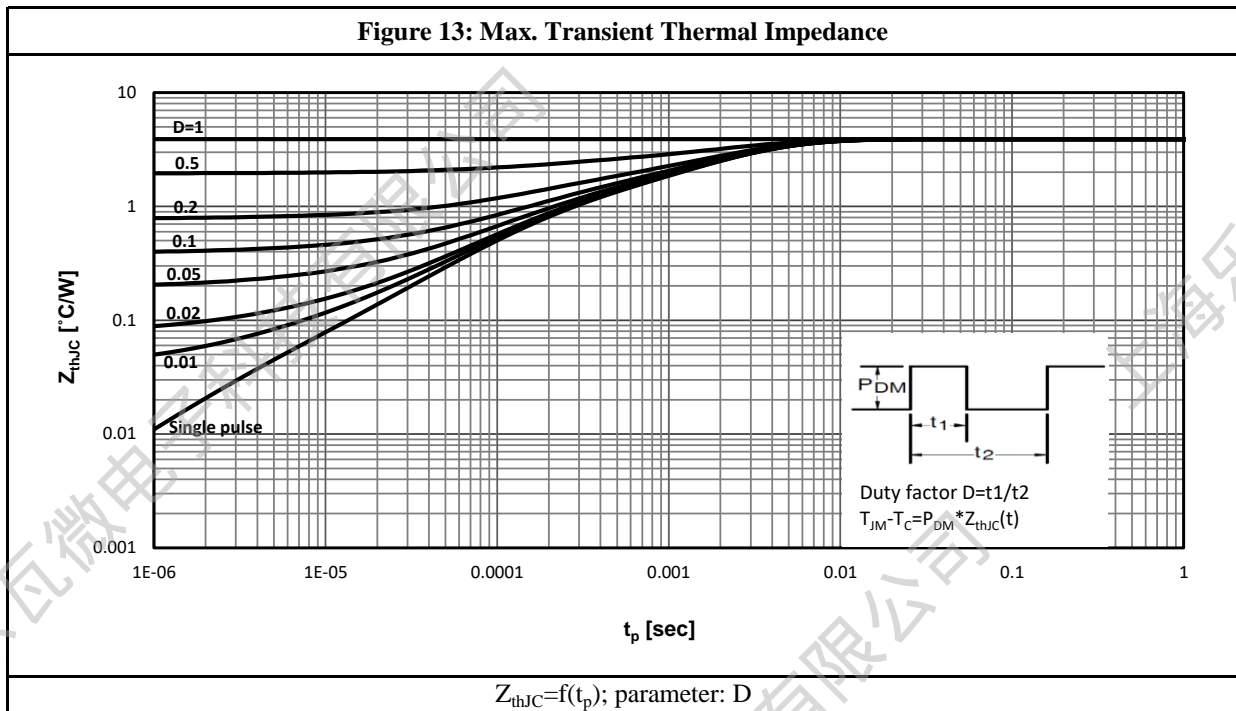

Test Circuit & Waveform:

Figure 14: Gate Charge Test Circuit & Waveform

Figure 15: Resistive Switching Test Circuit & Waveforms

Figure 16: Unclamped Inductive Switching Test Circuit & Waveforms

Package Outline:

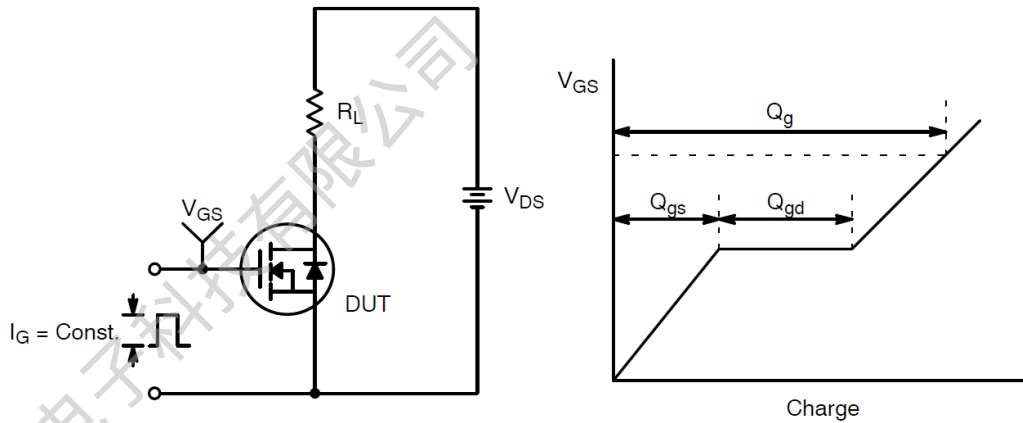
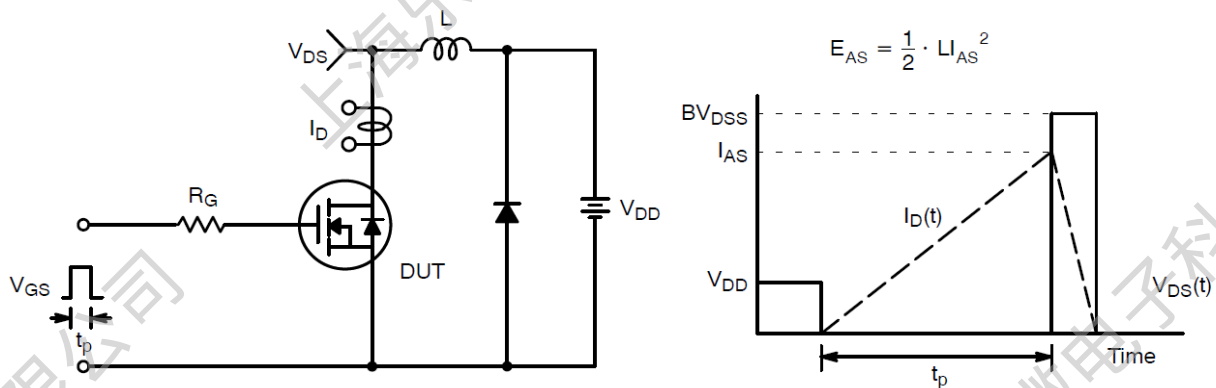
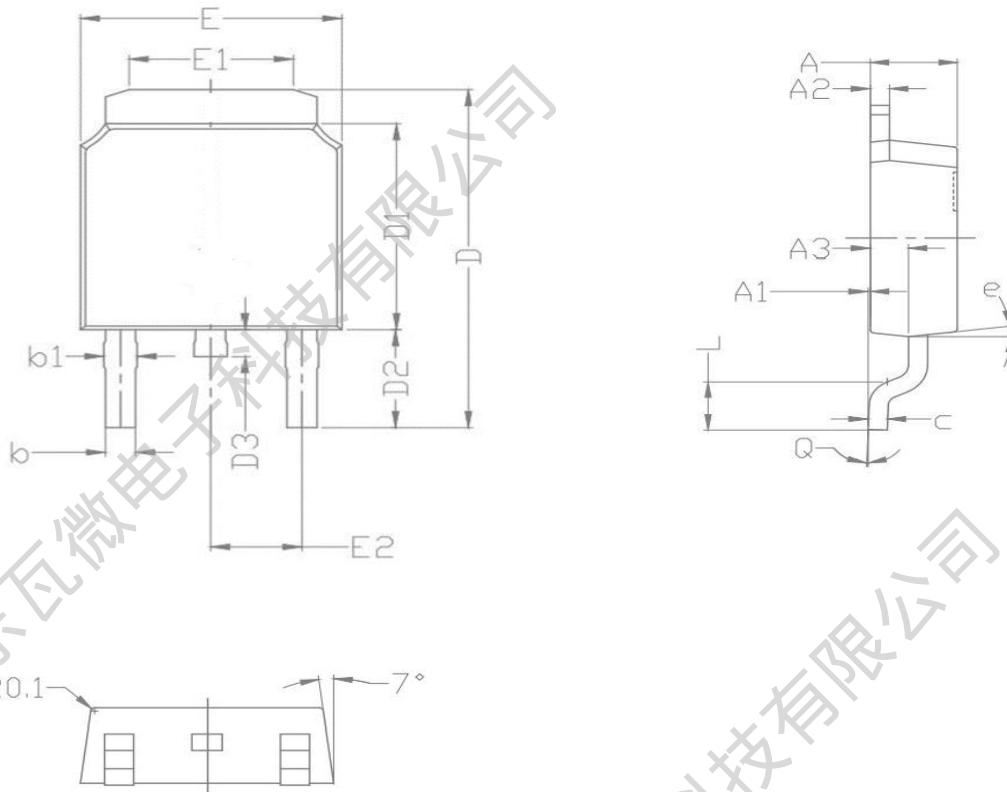
COMMON			
PKG	TO-252-2L		
Symbol	Min	Nom	Max
A	2.200	2.300	2.400
A1	0.000	0.075	0.150
A2	0.500	0.508	0.550
A3	0.960	1.010	1.060
b	0.740	0.760	0.800
b1	0.880	0.900	0.950
C	0.500	0.508	0.550
D	9.800	10.025	10.350
D1	6.050	6.100	6.180
D2	2.850	2.900	2.950
D3	0.600	0.800	1.000
E	6.550	6.600	6.700
E1	4.050	4.130	4.200
E2	2.25	2.286	2.3
L	1.400	1.500	1.600
e	7°		
Q	0°	2°	5°

Revision History:

Revison	Date	Descriptions
Rev 1.0	Dec.2021	Initial Version

Disclaimer:

The information in this document is believed to be accurate and reliable. However, no responsibility is assumed by LW-Micro for its use. All operating parameters must be designed, validated and tested to ensure they meet the requirements of your application. LW-Micro reserves the right to make any specification and/or circuitry changes without prior notification. Before starting a brand-new project, please contact LW-Micro Sales to get the most recent relevant information.

Mailing Address: Room 301, Building 2, No.1690 CaiLun Road, China (Shanghai) Pilot Free Trade Zone
Shanghai Lewa Micro-electronics Technology Co., Ltd