

General Description:

The LWN6045A23 uses advanced technology and design to provide excellent $R_{DS(ON)}$ with low gate charge. It can be used in a wide variety of applications. The package form is SOT-223, which accords with the ROHS standard and Halogen Free standard.

Features:

- Fast Switching
- Low Gate Charge and $R_{DS(ON)}$
- Low Reverse transfer capacitances

Applications:

- Power switching application
- Hard switched and high frequency circuits
- Uninterruptible power supply

100% DVDS Tested

100% Avalanche Tested



V_{DSS}	60	V
I_D	5.0	A
P_D	2.0	W
$R_{DS(ON)}$ TYPE	33	m Ω

Marking and Pin Assignment

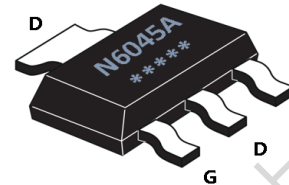

Inner Equivalent Principium Chart

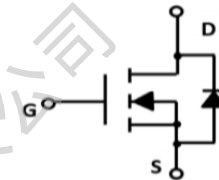

Package Marking and Ordering Information:

Marking	Part Number	Package	Packing	Qty.
N6045A	LWN6045A23	SOT-223	Reel	3000 Pcs

Absolute Maximum Ratings:

Symbol	Parameter	Value	Units
V_{DSS}	Drain-to-Source Voltage	60	V
I_D	Continuous Drain Current	$T_C=25^\circ\text{C}$	5.0
	Continuous Drain Current	$T_C=100^\circ\text{C}$	3.2
I_{DM}^{a1}	Pulsed Drain Current	20	A
E_{AS}^{a2}	Single pulse avalanche energy	56	mJ
V_{GS}	Gate-to-Source Voltage	± 20	V
P_D	Power Dissipation	2.0	W
T_J, T_{STG}	Operating Junction and Storage Temperature Range	150, -55 to 150	$^\circ\text{C}$
T_L	Maximum Temperature for Soldering	260	$^\circ\text{C}$

Thermal Characteristics:

Symbol	Parameter	Value	Units
$R_{\theta JC}$	Thermal Resistance, Junction-to-Ambient	0	$^\circ\text{C}/\text{W}$

Electrical Characteristic ($T_C = 25\text{ }^\circ\text{C}$, unless otherwise specified):

Static Characteristics						
Symbol	Parameter	Test Conditions	Value			Units
			Min.	Typ.	Max.	
V_{DSS}	Drain to Source Breakdown Voltage	$V_{GS}=0V, I_D=250\mu A$	60	--	--	V
I_{DSS}	Drain to Source Leakage Current	$V_{DS}=60V, V_{GS}=0V$	--	--	1.0	μA
$I_{GSS(F)}$	Gate to Source Forward Leakage	$V_{GS}=+20V, V_{DS}=0V$	--	--	100	nA
$I_{GSS(R)}$	Gate to Source Reverse Leakage	$V_{GS}=-20V, V_{DS}=0V$	--	--	-100	nA
$V_{GS(TH)}$	Gate Threshold Voltage	$V_{DS}=V_{GS}, I_D=250\mu A$	1.1	1.6	2.1	V
$R_{DS(ON)1}$	Drain-to-Source On-Resistance	$V_{GS}=10V, I_D=5.0A$	--	33	45	$m\Omega$
$R_{DS(ON)2}$	Drain-to-Source On-Resistance	$V_{GS}=4.5V, I_D=5.0A$	--	38	55	$m\Omega$

Dynamic Characteristics						
Symbol	Parameter	Test Conditions	Value			Units
			Min.	Typ.	Max.	
C_{iss}	Input Capacitance	$V_{GS} = 0V$	--	990	--	pF
C_{oss}	Output Capacitance	$V_{DS} = 30V$	--	41.8	--	
C_{riss}	Reverse Transfer Capacitance	$f = 1.0MHz$	--	38.2	--	
R_G	Gate resistance	$V_{GS}=0V, V_{DS}$ Open	--	1.4	--	Ω

Resistive Switching Characteristics						
Symbol	Parameter	Test Conditions	Value			Units
			Min.	Typ.	Max.	
$t_{d(ON)}$	Turn-on Delay Time	$I_D = 5.0A$	--	8.0	--	ns
t_r	Rise Time	$V_{DS} = 30V$	--	3.6	--	
$t_{d(OFF)}$	Turn-Off Delay Time	$V_{GS} = 10V$	--	19.2	--	
t_f	Fall Time	$R_G = 3.0\Omega$	--	3.2	--	
Q_g	Total Gate Charge	$V_{GS} = 10V$	--	22	--	nC
Q_{gs}	Gate Source Charge	$V_{DS} = 30V$	--	3.39	--	
Q_{gd}	Gate Drain Charge	$I_D = 5.0A$	--	4.67	--	

Source-Drain Diode Characteristics						
Symbol	Parameter	Test Conditions	Value			Units
			Min.	Typ.	Max.	
I_S	Diode Forward Current	$T_C = 25\text{ }^\circ\text{C}$	--	--	5.0	A
V_{SD}	Diode Forward Voltage	$I_S=5.0A, V_{GS}=0V$	--	--	1.2	V
t_{rr}	Reverse Recovery time	$I_S=5.0A, V_{DD}=30V$	--	27	--	ns
Q_{rr}	Reverse Recovery Charge	$dI/dt=100A/\mu s$	--	17	--	nC

a1: Repetitive rating; pulse width limited by maximum junction temperature

a2: $V_{DD}=30V, L=0.5mH, R_G=25\Omega$, Starting $T_J=25\text{ }^\circ\text{C}$

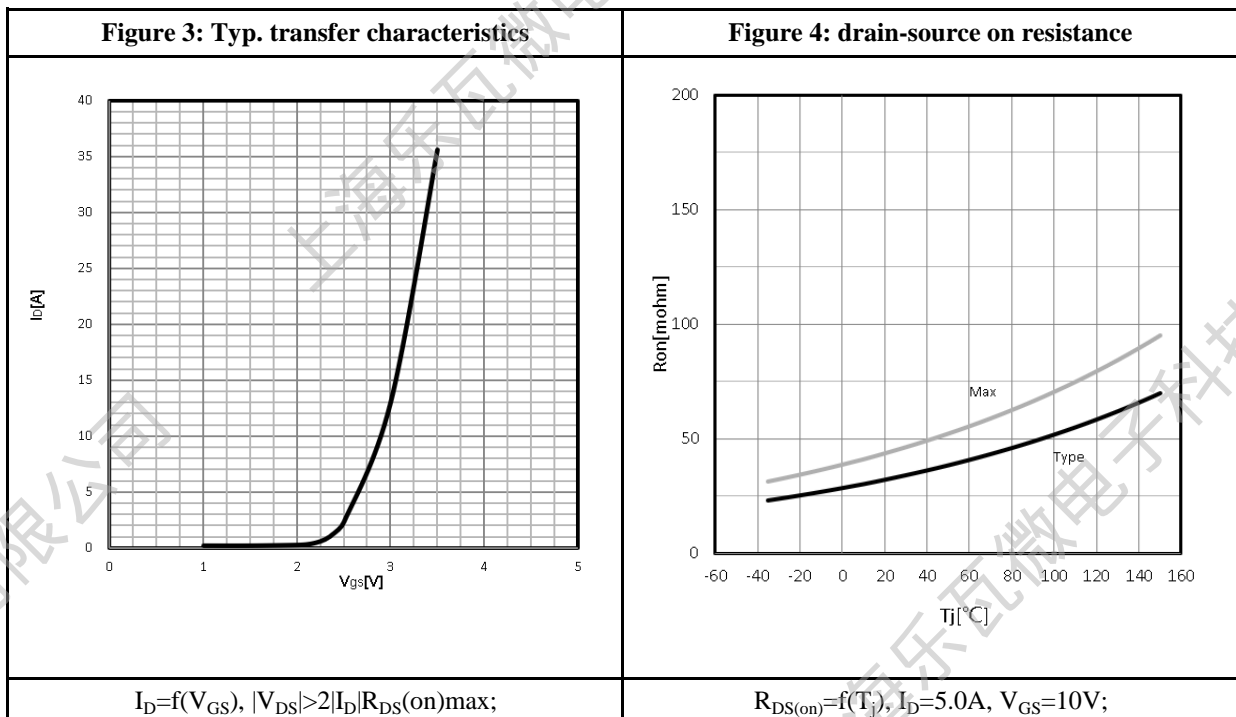
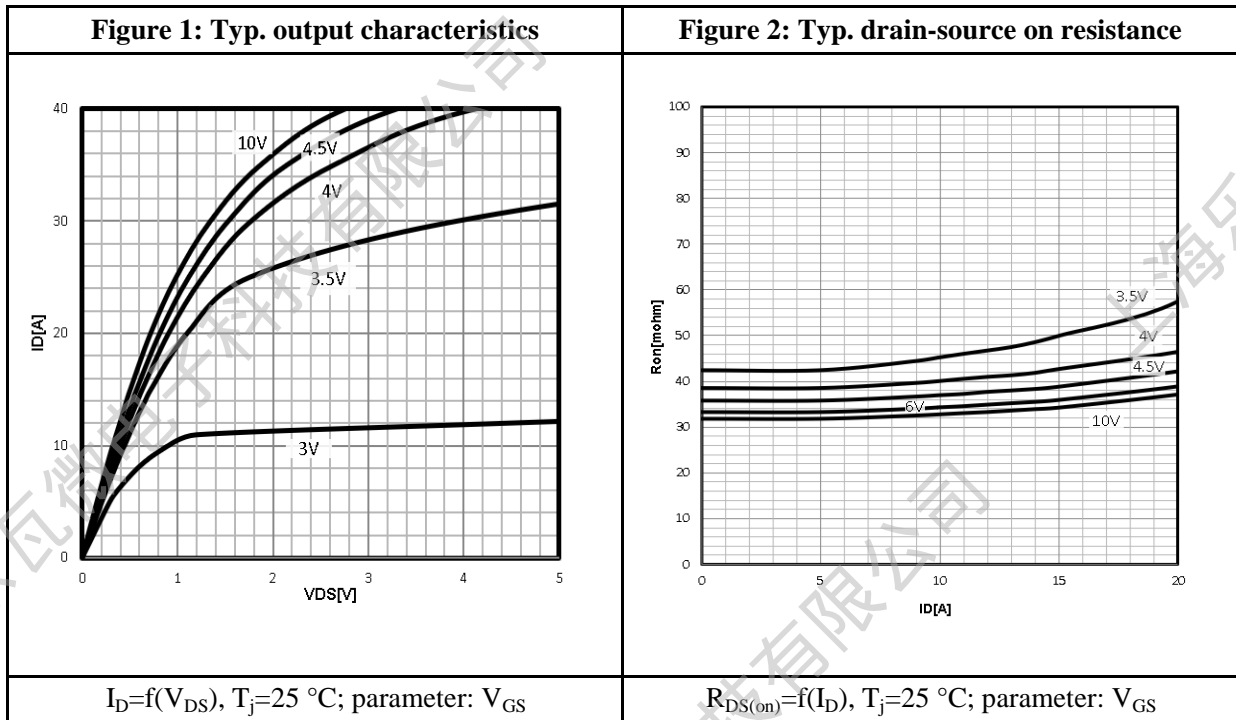
Characteristics Curve:

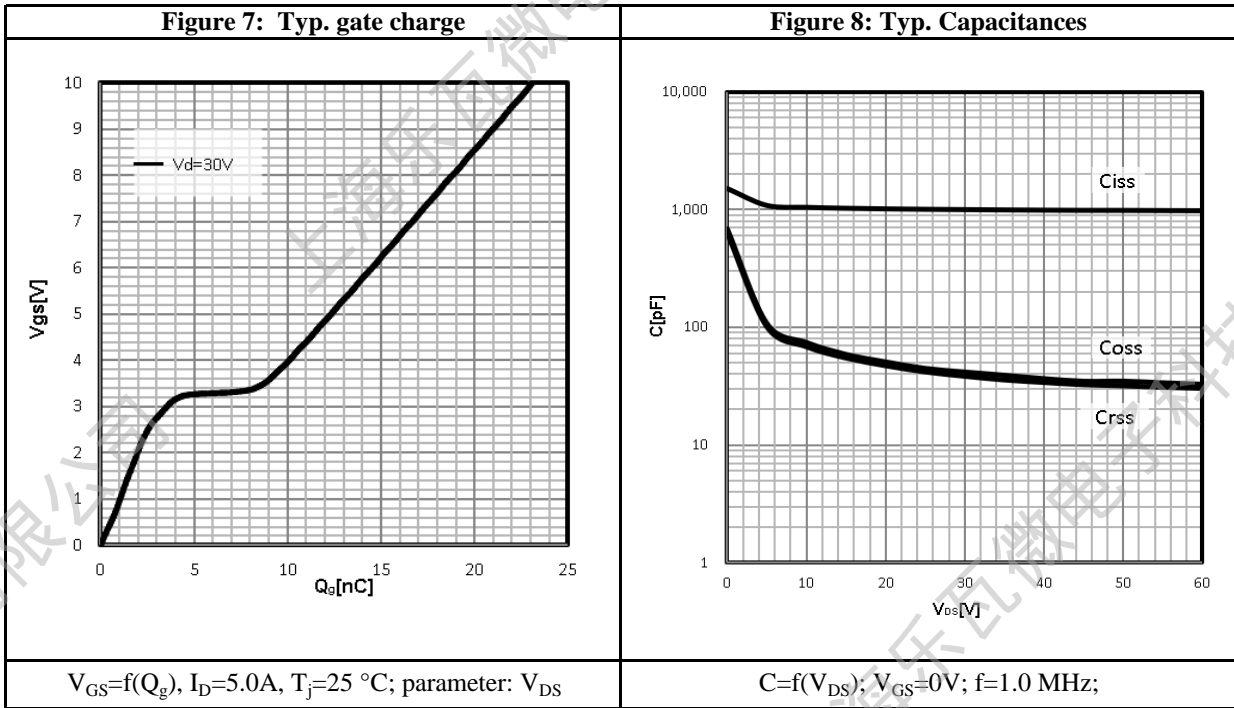
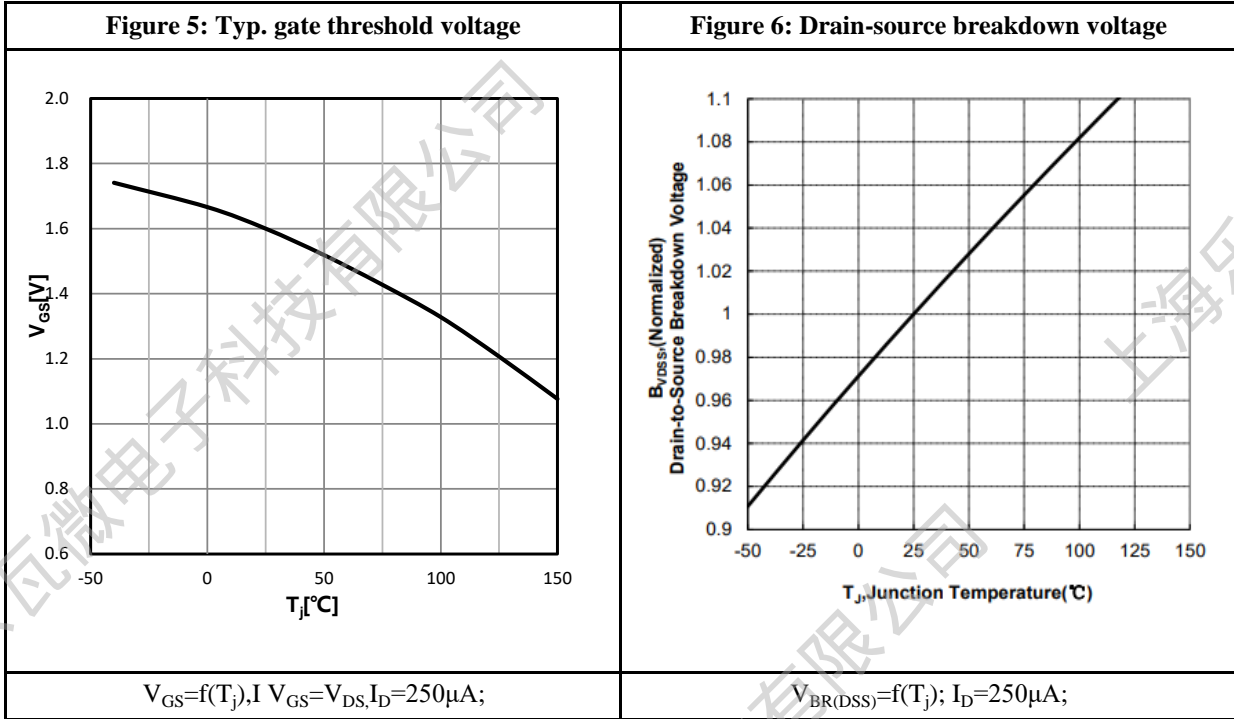

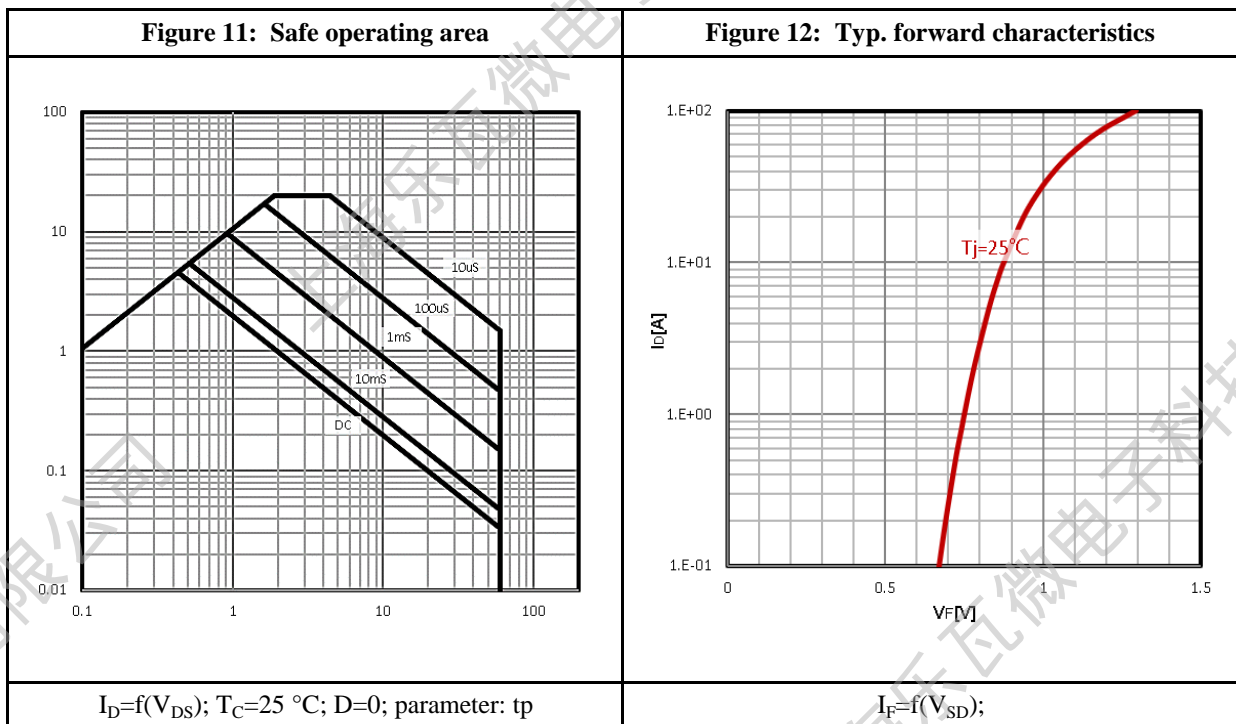
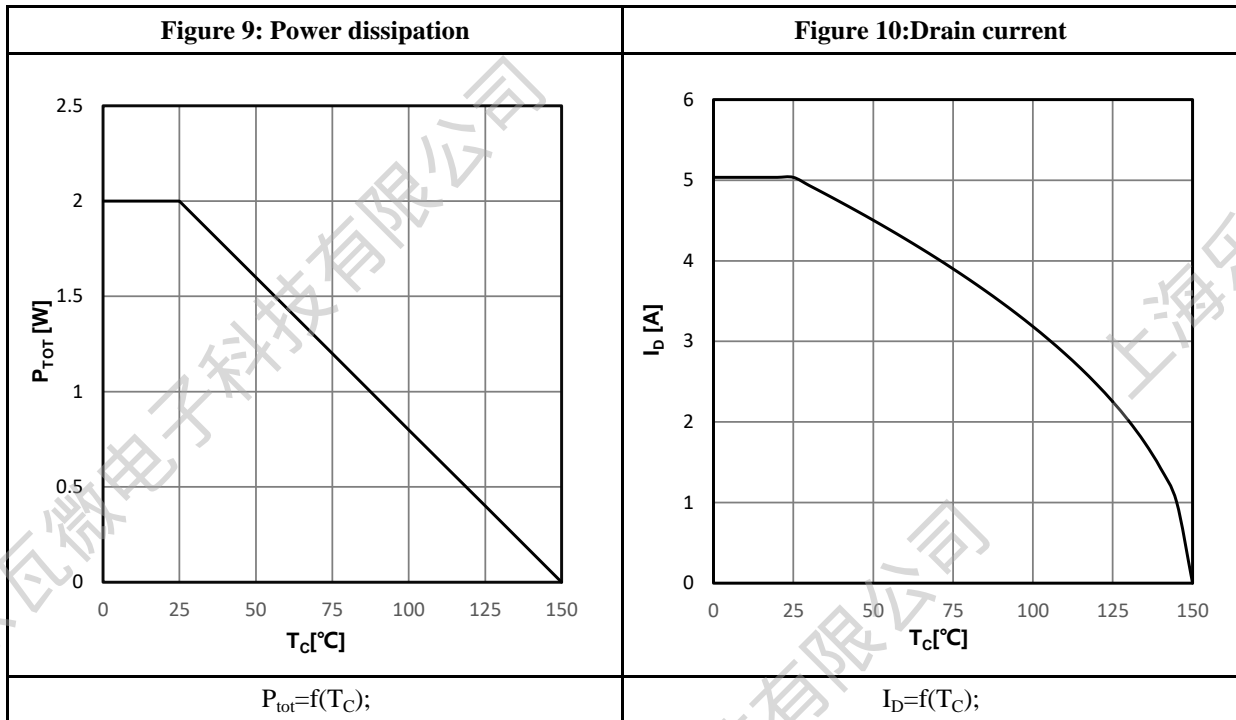
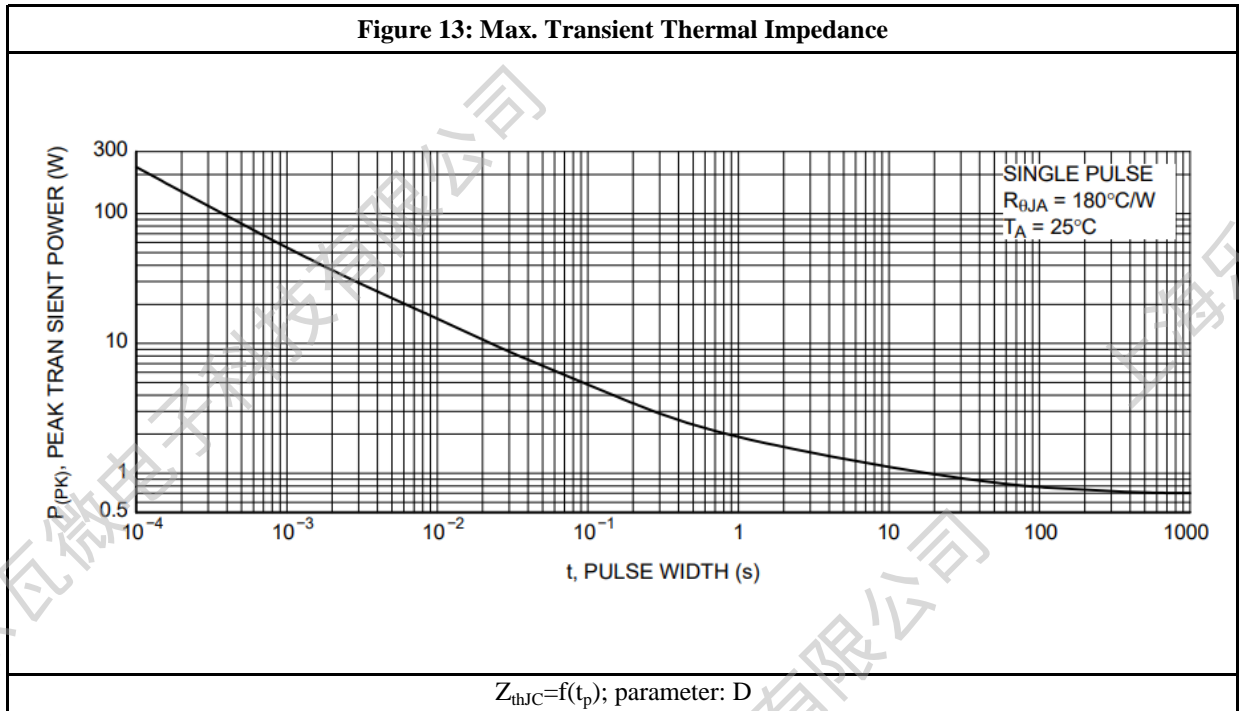

Figure 13: Max. Transient Thermal Impedance



Test Circuit & Waveform:

Figure 14: Gate Charge Test Circuit & Waveform

Figure 15: Resistive Switching Test Circuit & Waveforms

Figure 16: Unclamped Inductive Switching Test Circuit & Waveforms

Package Outline:

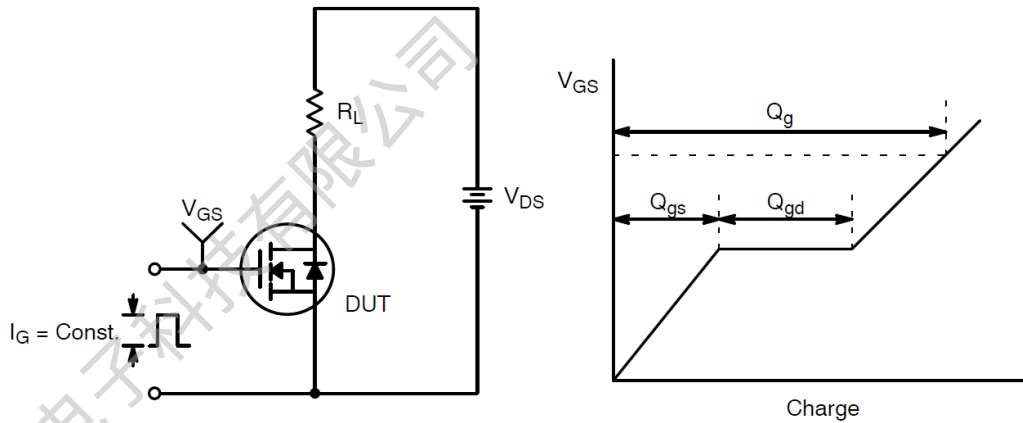
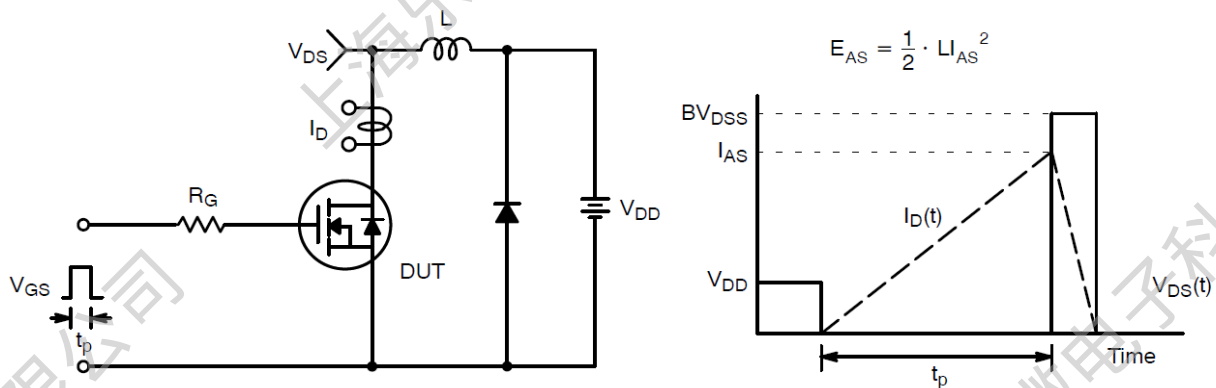
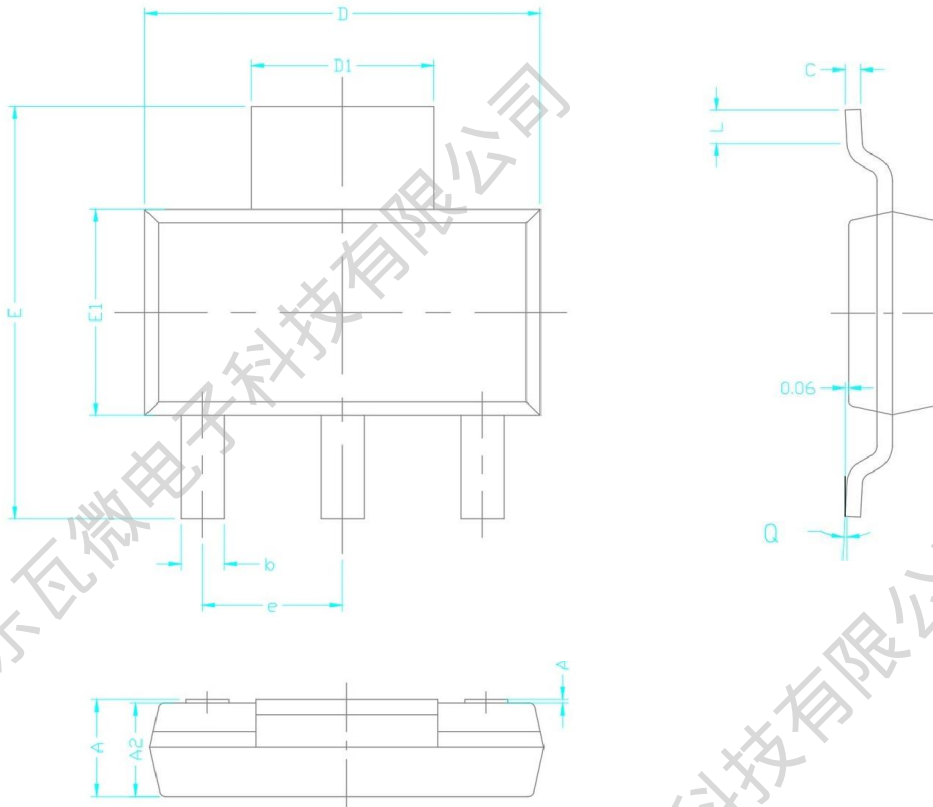
COMMON DIMENSION (MM)			
PKG	SOT-223		
Symbol	MIN	MON	MAX
A	1.520	1.580	1.720
A1	0.010	0.060	0.150
A2	1.470	1.520	1.570
b	0.660	0.710	0.800
c	0.250	0.280	0.350
D	6.500	6.600	6.750
D1	2.900	3.000	3.100
E	6.700	7.000	7.300
E1	3.300	3.500	3.700
L	0.750 REF		
e	2.300 REF		
Q	0°	4°	10°

Revision History:

Revison	Date	Descriptions
Rev 1.0	Feb.2024	Initial Version

Disclaimer:

The information in this document is believed to be accurate and reliable. However, no responsibility is assumed by LW-Micro for its use. All operating parameters must be designed, validated and tested to ensure they meet the requirements of your application. LW-Micro reserves the right to make any specification and/or circuitry changes without prior notification. Before starting a brand-new project, please contact LW-Micro Sales to get the most recent relevant information.

Mailing Address: Room 301, Building 2, No.1690 CaiLun Road, China (Shanghai) Pilot Free Trade Zone
Shanghai Lewa Micro-electronics Technology Co., Ltd