

**DFNWB3×2-8L Plastic-Encapsulate Transistors**

**CJZ253PL TRANSISTOR (PNP)**

**FEATURE**

- Low Saturation Voltage
- High DC Current Gain

**MARKING:**

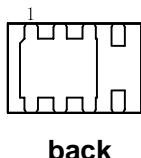
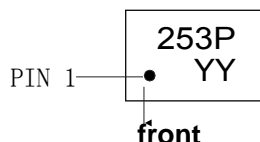

253P = Device code  
YY=Date Code  
Solid dot=Pin1 indicator

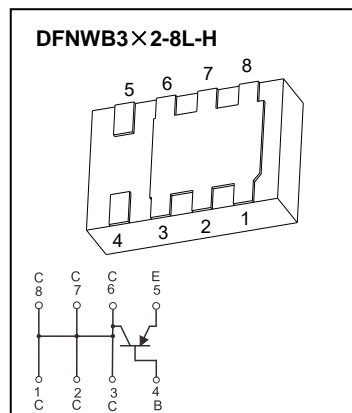

**MAXIMUM RATINGS (T<sub>a</sub>=25°C unless otherwise noted)**

Symbol	Parameter	Value	Unit
V <sub>CB0</sub>	Collector-Base Voltage	-45	V
V <sub>CE0</sub>	Collector-Emitter Voltage	-32	V
V <sub>EB0</sub>	Emitter-Base Voltage	-7.5	V
I <sub>c</sub>	Collector Current	-3	A
P <sub>c</sub>	Power dissipation <sup>a</sup>	3.0	W
	Power dissipation <sup>b</sup>	1.0	W
T <sub>stg</sub>	Operation Junction and Storage Temperature Range	-55~+150	°C
T <sub>L</sub>	Lead Temperature	260	°C

a Surface mounted on FR-4 Board using 1 square inch pad size, 1oz copper

b Surface mounted on FR-4 board using minimum pad size, 1oz copper

**ELECTRICAL CHARACTERISTICS (T<sub>a</sub>=25°C unless otherwise specified)**

Parameter	Symbol	Test conditions	Min	Typ	Max	Unit
Collector-base breakdown voltage	V <sub>(BR)CBO</sub>	I <sub>C</sub> =-0.1mA, I <sub>E</sub> =0	-45			
Collector-emitter breakdown voltage	V <sub>(BR)CEO</sub>	I <sub>C</sub> =-10mA, I <sub>B</sub> =0	-32			
Emitter-base breakdown voltage	V <sub>(BR)EBO</sub>	I <sub>E</sub> =-0.1mA, I <sub>C</sub> =0	-7.5			V
Collector cut-off current	I <sub>CBO</sub>	V <sub>CB</sub> =-20V, I <sub>E</sub> =0			-25	nA
Emitter cut-off current	I <sub>EBO</sub>	V <sub>EB</sub> =-6V, I <sub>C</sub> =0			-25	nA
DC current gain	h <sub>FE</sub> *	V <sub>CE</sub> =-2V, I <sub>C</sub> =-0.01A	300			
		V <sub>CE</sub> =-2V, I <sub>C</sub> =-0.1A	280			
		V <sub>CE</sub> =-2V, I <sub>C</sub> =-2A	140			
		V <sub>CE</sub> =-2V, I <sub>C</sub> =-6A	15			
Collector-emitter saturation voltage	V <sub>CE(sat)</sub> *	I <sub>C</sub> =-0.1A, I <sub>B</sub> =-10mA			-30	mV
		I <sub>C</sub> =-1A, I <sub>B</sub> =-20mA			-220	mV
		I <sub>C</sub> =-1.5A, I <sub>B</sub> =-50mA			-250	mV
		I <sub>C</sub> =-2.5A, I <sub>B</sub> =-150mA			-350	mV
		I <sub>C</sub> =-3.5A, I <sub>B</sub> =-350mA			-400	mV
Base-emitter saturation voltage	V <sub>BE(sat)</sub> *	I <sub>C</sub> =-3.5A, I <sub>B</sub> =-350mA			-1.4	V
Base-emitter turn-on voltage	V <sub>BE(on)</sub> *	V <sub>CE</sub> =-2V, I <sub>C</sub> =-2.0A			-1.4	V
Transition frequency	f <sub>T</sub>	V <sub>CE</sub> =-10V, I <sub>C</sub> =-50mA, f=100MHz	150			MHz

\*Pulse test: pulse width ≤300μs, duty cycle ≤ 2.0%.

# Typical Characteristics

Static Characteristic

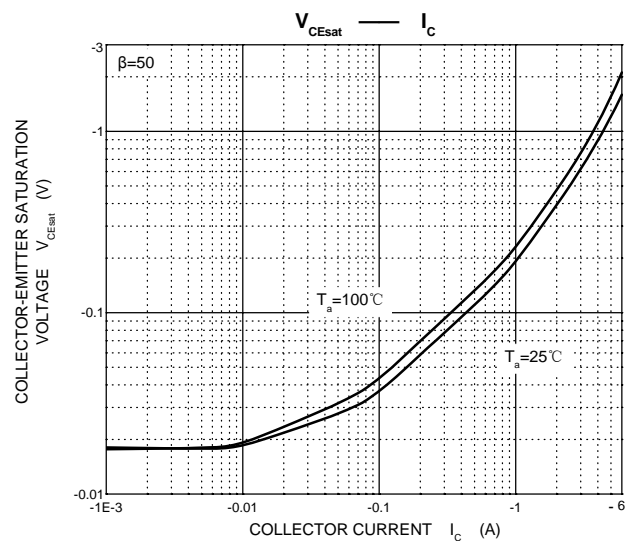
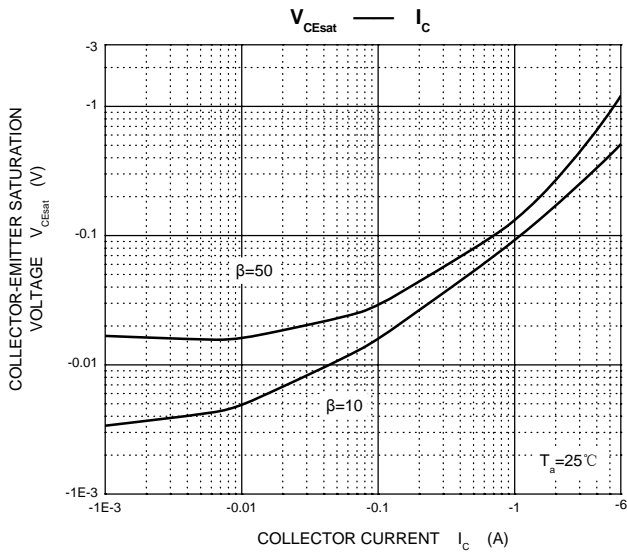
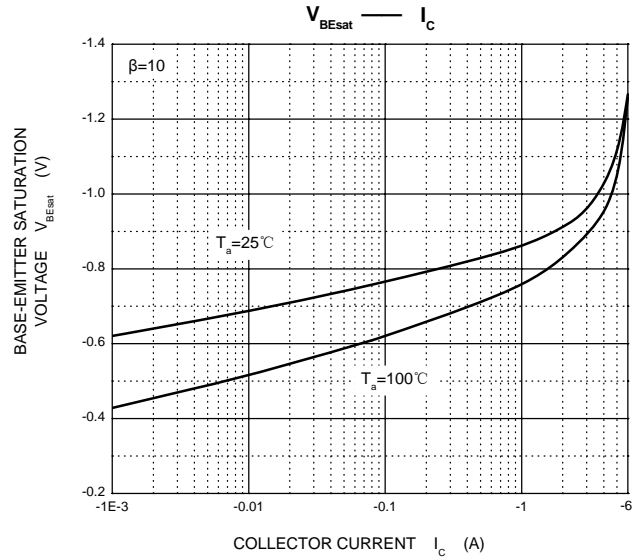
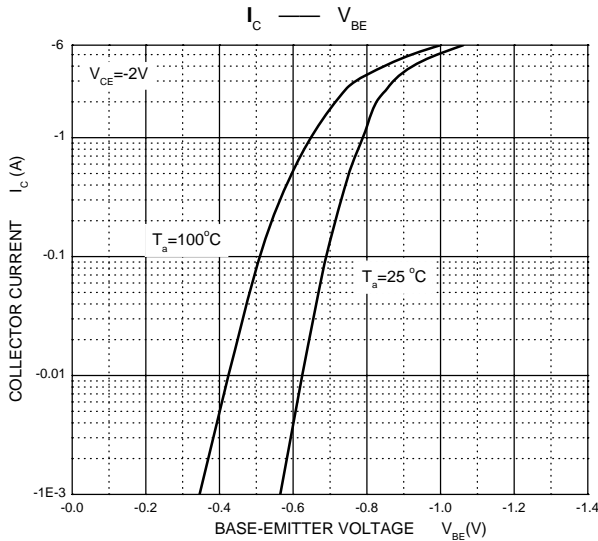
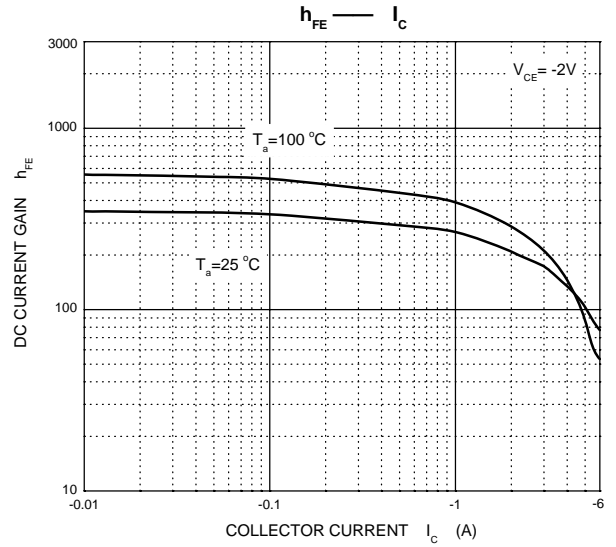
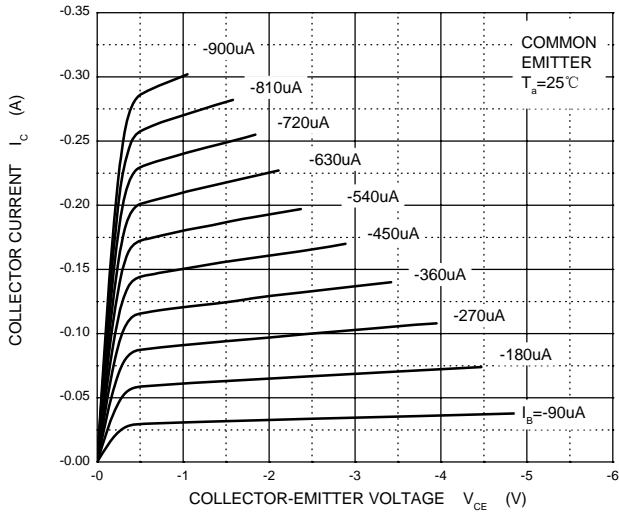

# Typical Characteristics

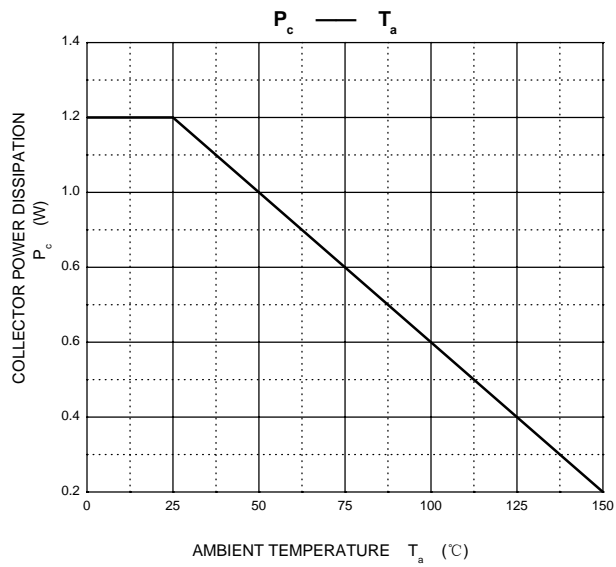
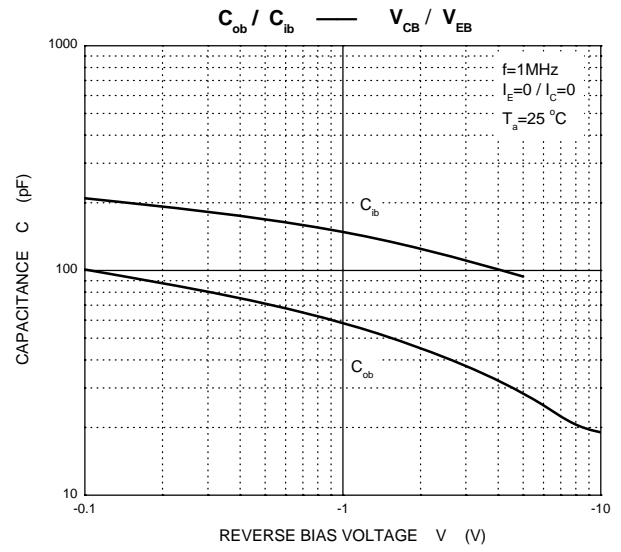
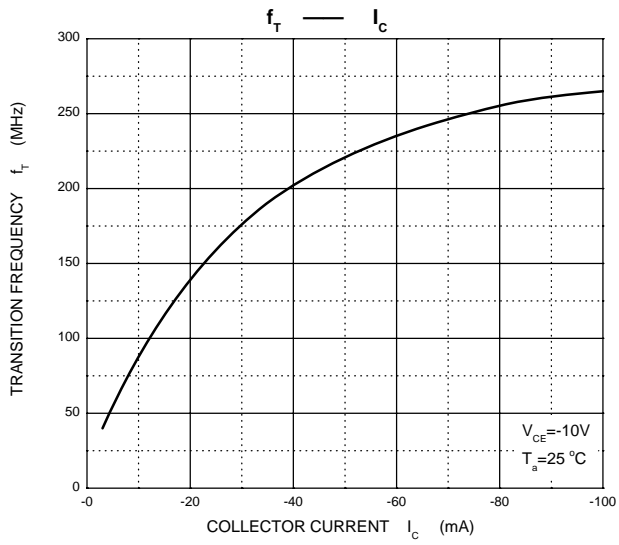

## DFNWB3×2-8L-H Package Outline Dimensions(Unit:mm)

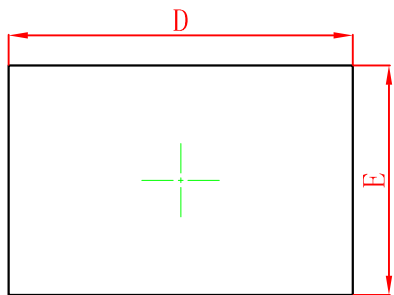

TOP VIEW

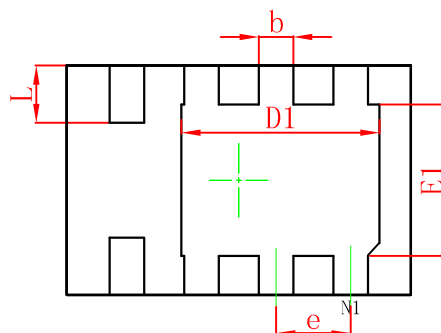

BOTTOM VIEW

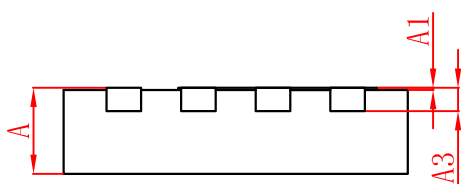

SIDE VIEW

Symbol	Dimensions In Millimeters		Dimensions In Inches	
	Min.	Max.	Min.	Max.
A	0.700	0.800	0.028	0.031
A1	0.000	0.050	0.000	0.002
A3	0.203REF.		0.008REF.	
D	2.900	3.100	0.114	0.122
E	1.900	2.100	0.075	0.083
D1	1.627	1.827	0.064	0.072
E1	1.220	1.420	0.048	0.056
b	0.250	0.350	0.010	0.014
e	0.650TYP.		0.026TYP.	
L	0.424	0.576	0.017	0.023

## DFNWB3×2-8L-H Suggested Pad Layout

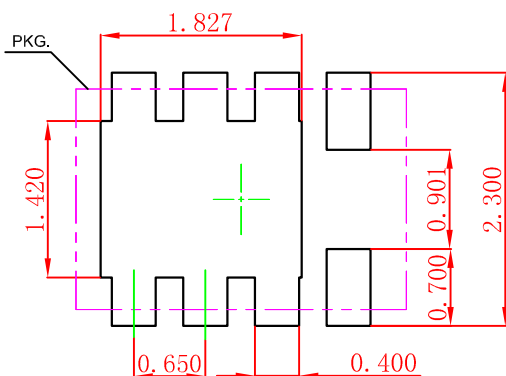

**Note:**

1. Controlling dimension: in millimeters.
2. General tolerance:  $\pm 0.050\text{mm}$ .
3. The pad layout is for reference purposes only.

**NOTICE**

JSCJ reserves the right to make modifications, enhancements, improvements, corrections or other changes without further notice to any product herein. JSCJ does not assume any liability arising out of the application or use of any product described herein.

# DFNWB3X2-8L Tape and Reel

## DFNWB3\*2-8L Embossed Carrier Tape

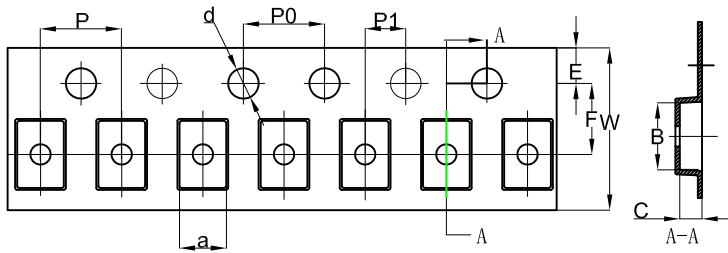

### Packaging Description:

DFNWB3\*2-8L parts are shipped in tape. The carrier tape is made from a dissipative (carbon filled) polycarbonate resin. The cover tape is a multilayer film (Heat Activated Adhesive in nature) primarily composed of polyester film, adhesive layer, sealant, and anti-static sprayed agent. These reeled parts in standard option are shipped with 3,000 units per 7" or 18.0cm diameter reel. The reels are clear in color and is made of polystyrene plastic (anti-static coated).  
ALL DIM IN mm

Dimensions are in millimeter										
Pkg type	a	B	C	d	E	F	P0	P	P1	W
DFNWB3*2-8L	2.30	3.30	1.10	Ø1.50	1.75	3.50	4.00	4.00	2.00	8.00

## DFNWB3\*2-8L Tape Leader and Trailer

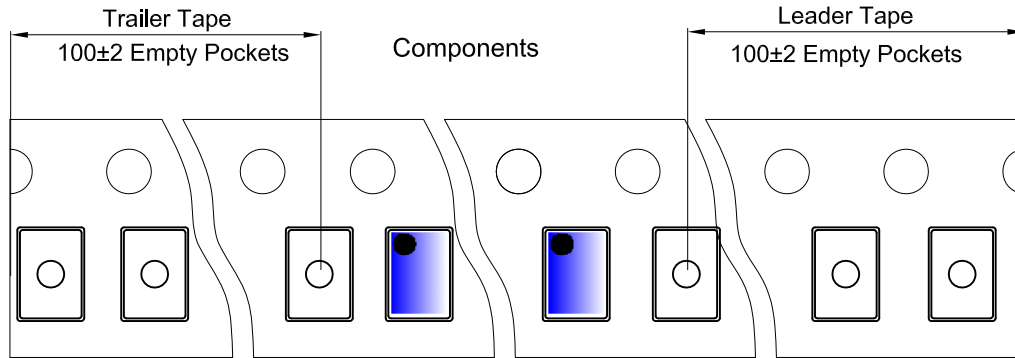

## DFNWB3\*2-8L Reel

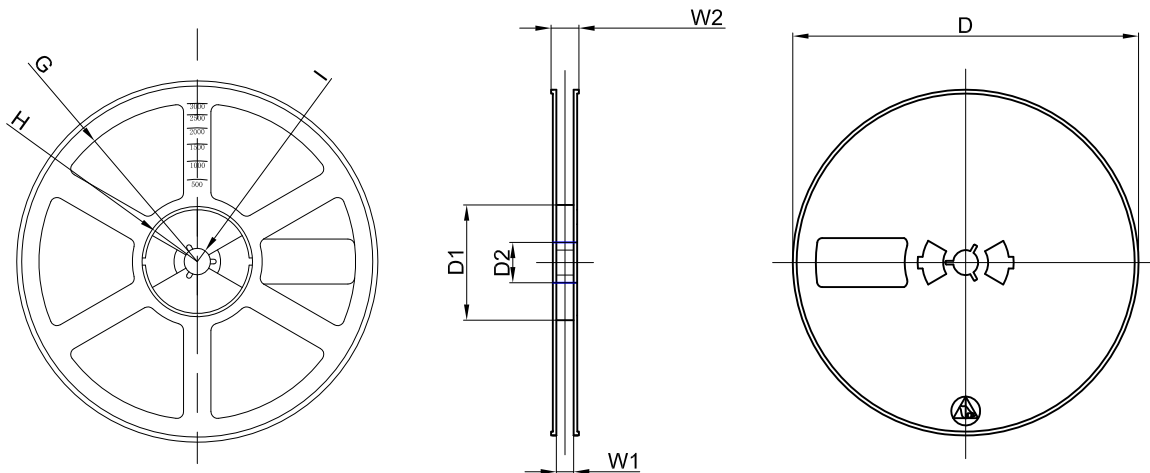

Dimensions are in millimeter								
Reel Option	D	D1	D2	G	H	I	W1	W2
7" Dia	Ø180.00	60.00	13.00	R78.00	R25.60	R6.50	9.50	13.10

REEL	Reel Size	Box	Box Size(mm)	Carton	Carton Size(mm)	G.W.(kg)
3,000 pcs	7 inch	30,000 pcs	203×203×195	120,000 pcs	438×438×220	